



Operations and Maintenance Recommended Practices



2nd Edition 2017

ACKNOWLEDGEMENTS

The American Wind Energy Association (AWEA) Operations and Maintenance (O&M) Recommended Practice (RP) are developed through a consensus process of interested parties by AWEA O&M Committee. These RPs represent decades of experience from the members of the AWEA O&M Committee. This expertise, often gained from other industry sectors, helps inform, train and support wind energy technicians and managers in their efforts to improve reliability and project performance. These are, in general, the nuts and bolts of wind energy power plant maintenance and operations. As the industry matures, additional maintenance strategies and operations philosophies will certainly come to the fore, however, these basics will always be required knowledge for new technicians and asset managers expanding their areas of responsibility.

Development of the AWEA O&M RPs started in 2009, with the first edition publication in 2013. The current version is the result of hundreds of hours of volunteer time by many people and we, the AWEA O&M Committee Chairperson, Kevin Alewine, and Vice Chairperson, Krys Rootham, wish to thank all of the individuals who have participated in the AWEA O&M Committee to develop these documents and the companies that continue to allow those efforts, as well as, sharing their technical know-how.

AWEA Operations and Maintenance Committee:

- AWEA O&M Steering Committee
- Balance of Plant Subcommittee
- Blades Subcommittee
- Condition Monitoring Subcommittee
- Data Collection and Reporting Subcommittee
- End of Warranty Subcommittee
- Gearbox Subcommittee
- Generator Subcommittee
- Operations Subcommittee
- Tower Subcommittee
- Turbine Auxiliary Subcommittee

And a special thank you to the AWEA Quality Assurance Committee for their work on the Quality Assurance Chapter.

Again, thanks to everyone for their continued support for development of these recommended practices. Please contact any of us if you have questions or comments (OM@awea.org) regarding the Committee or these documents.

Thanks again for the efforts and accomplishments,

Kevin Alewine, Shermco
Chairperson, AWEA O&M Committee

FORWARD

The AWEA Operation and Maintenance Recommended Practices are intended to provide establish expectations and procedures to ensure all personnel performing service and maintenance on wind turbines have a minimum knowledge base.

The AWEA Operation and Maintenance Recommended Practices (O&M RPs) are not “best” practices nor the *only* procedures that should be followed. They represent suggestions from experts in the field who have refined their procedures over time. The preferred procedures in the future will no doubt change with improved communications, technology, materials and experience. These AWEA O&M RPs will be revised as needed.

The AWEA O&M RPs were initiated in 2009 and created by members of the AWEA O&M Committee to ensure that the future wind industry benefits from the experience gained from the past. Individual members donated their time and expertise to document these procedures.

The AWEA O&M RPs are organized into “chapters” to address the major functions of a wind turbine and its operation. Individual recommended practices address specific procedures used in each of those areas.

Many other organizations have developed consensus standards, recommended practices, best practices, etc. that also offer excellent supporting information for effective wind farm operations and maintenance. IEEE (Institute of Electrical and Electronic Engineers), NETA (International Electrical Testing Association), SMRP (Society for Maintenance and Reliability Professionals), AGMA (American Gear Manufacturer’s Association) just to name a few. These sources should be reviewed in developing sound maintenance strategies.

OCCUPATIONAL SAFETY AND HEALTH NOTICE

The Occupational Safety and Health Administration (OSHA) was established by Congress through the Occupational Safety and Health (OSH) Act of 1970, to assure safe and healthful working conditions for working men and women by authorizing enforcement of the standards developed under the Act; by assisting and encouraging the States in their efforts to assure safe and healthful working conditions; by providing for research, information, education, and training in the field of occupational safety and health; and for other purposes.

The Secretary of Labor promulgates rules as OSH standards by incorporating national consensus standards and through the federal regulatory rulemaking process. The American Wind Energy Association (AWEA) cannot determine or prescribe how member companies should evaluate their compliance obligations under OSHA's standards. Each employer must make its own determinations depending on the condition of each worksite. AWEA strongly encourages its members to develop their own written program to address worker safety and health procedures, programs, and hazard assessments, as well as provide trainings for their workers in these areas.

The wind energy industry is covered by OSHA regulations for worker safety and health practices. §29 C.F.R 1910.269 is the OSHA standard that regulates employee safety in the operation and maintenance of electric power generation, transmission and distribution facilities and installations, which covers the wind energy industry and §29 C.F.R 1926, for construction activities.

Each employer shall choose to the appropriate regulation and standards to work in the wind energy industry and must be prepared to justify their determination, development, and implementation of their written program. Employers must also consider the regulatory requirements of state occupational safety and health plans. The OSH Act of 1970 encourages states to develop and operate their own job safety and health programs, which there are twenty-six (26) states and jurisdictions that operate OSHA-approved State Plans (SPS). Twenty-two (22) states operate complete state plans, while five states cover public employees only. SPS must set job safety and health standards that are "at least as effective as" comparable federal standards, including hazards not addressed by federal standards.

NOTICE AND DISCLAIMER

The information in this Document was considered technically sound by the consensus of persons engaged in the development and approval of the document at the time it was developed. Consensus does not necessarily mean that there is unanimous agreement among every person participating in the development of this document.

AWEA disclaims liability for any personal injury, property or other damages of any nature whatsoever, whether special, indirect, consequential or compensatory, directly or indirectly resulting from the publication, use of, application, or reliance on this document. AWEA disclaims and makes no guaranty or warranty, express or implied, as to the accuracy or completeness of any information published herein, and disclaims and makes no warranty that the information in this document will fulfill any of your particular purposes or needs. AWEA does not undertake to guarantee the performance of any individual manufacturer or seller's products or services by virtue of this standard or guide.

In publishing and making this document available, AWEA is not undertaking to render professional or other services for or on behalf of any person or entity. Nor is AWEA undertaking to perform any duty owed by any person or entity to someone else. Anyone using this document should rely on his or her own independent judgment or, as appropriate, seek the advice of a competent professional in determining the exercise of reasonable care in any given circumstances. Information and other standards on the topic covered by this publication may be available from other sources, which the user may wish to consult for additional views or information not covered by this publication.

AWEA has no power, nor does it undertake to police or enforce compliance with the contents of this document. AWEA does not certify, test or inspect products, design or installation for safety or health purposes. Any certification or other statement of compliance with any health or safety-related information in this document shall not be attributable to AWEA and is solely the responsibility of the certifier or maker of the statement.

If you breach this agreement, your right to further use this Document will be immediately revoked.

This document is proprietary and its use is subject to a legally binding license agreement and disclaimer (the "Agreement"). Do not use this document for any purpose unless and until you read the agreement. By viewing or otherwise using this document, you hereby warrant and represent that you have read and agree to be legally bound by the agreement and are authorized to bind not only yourself to the agreement, but the organization for which you are accessing the document. If the agreement is not acceptable and you are unwilling to be bound by it, please do not view or otherwise make any use of the document.

PUBLISHED BY:

American Wind Energy Association
1501 M Street, NW, Suite 900
Washington, DC 20005
202.383.2500

COPYRIGHT

©2017 American Wind Energy Association. All rights reserved. You may download, reproduce and print this white paper and any portion hereof (the “Document”) for internal use only (which use may include internal use by employees of your company), and, by downloading or accessing the Document, you agree: (i) that you shall not sell or otherwise engage in any distribution of this Document; (ii) that you shall not make any alterations, modifications, deletions or other changes to this Document without the express written consent of American Wind Energy Association (“AWEA”); and (iii) to indemnify and hold AWEA harmless for any loss or damage, including reasonable attorney's fees, that the AWEA may incur, directly or indirectly, as a result of your use of this Document.

AWEA assumes no liability for reliance on the contents of this document. AWEA is providing this document for reference only in furtherance of AWEA’s nonprofit and tax-exempt mission. AWEA makes no representation or warranty about the information contained in this document, including, without limitation, the suitability of the information contained in this document for any purpose. It is offered only as general guidance and does not constitute legal, medical, or professional advice. This document is not intended to, nor does it, include information regarding safe operations and maintenance practices. Any recommended practices, guidance or standards contained in this document should be considered on a case by case basis and used in accordance with your company's internal safety and other operating requirements as well as all applicable laws, regulations and recommended practices addressing safety and regulatory compliance (such as OSHA and ANSI requirements). You should consider seeking legal or professional advice on all matters concerning safety and regulatory compliance.



Operations and Maintenance Recommended Practices Full Table of Contents

Chapter One: Gearbox

- RP 101 Wind Turbine Gear Lubricant Flushing Procedures
- RP 102 Wind Turbine Gearbox Oil Sampling Procedure
- RP 105 Factors Indicating Gear Lube Oil Change
- RP 106 Wind Turbine Gear Oil Filtration Procedures

Chapter Two: Generator and Electrical

- RP 201 Generator Collector Ring Assembly Maintenance
- RP 202 Grease Lubricated Bearing Maintenance
- RP 203 Generator Off-Line Electrical Testing
- RP 204 Converter Maintenance
- RP 207 Wind Turbine Generator and Converter Types
- RP 208 Shaft Current Management

Chapter Three: Rotor and Blades

- RP 301 Wind Turbine Blades
- RP 302 Rotor Hubs
- RP 304 Rotor Lightning Protection Systems

Chapter Four: Towers

- RP 401 Foundation Inspections, Maintenance, Base Bolt Tensioning
- RP 402 Fall Protection, Rescue Systems, Climb Assist and Harness
- RP 404 Wind Turbine Elevators

Chapter Five: Data Collection and Reporting

- RP 502 Smart Grid Data Reporting
- RP 503 Wind Turbine Reliability
- RP 504 Wind Forecasting Data
- RP 505 Asset Identification and Data Reporting

Operations and Maintenance Recommended Practices Full Table of Contents

Chapter Five: Data Collection and Reporting (continued)

- RP 506 Wind Turbine Key Performance Indicators
- RP 507 Wind Turbine Condition Based Maintenance
- RP 508 Oil Analysis Data Collection and Reporting Procedures
- RP 509 GADS Reporting Practices
- RP 510 Substation Data Collection

Chapter Six: Balance of Plant

- RP 601 Wind Energy Power Plant Collector System Maintenance
- RP 602 Wind Energy Power Plant Substation and Transmission Line Maintenance

Chapter Seven: End of Warranty

- RP 701 Wind Turbine End of Warranty Inspections

Chapter Eight: Condition Based Maintenance

- RP 801 Condition Based Maintenance
- RP 811 Vibration Analysis for Wind Turbines
- RP 812 Wind Turbine Main Bearing Grease Sampling Procedures
- RP 813 Wind Turbine Generator Bearing Grease Sampling Procedures
- RP 814 Wind Turbine Pitch Bearing Grease Sampling Procedures
- RP 815 Wind Turbine Grease Analysis Test Methods
- RP 816 Wind Turbine Temperature Measurement Procedures
- RP 817 Wind Turbine Nacelle Process Parameter Monitoring
- RP 818 Wind Turbine On-line Gearbox Debris Condition Monitoring
- RP 819 Online Oil Condition Monitoring
- RP 821 Wind Turbine Blade Condition Monitoring
- RP 831 Condition Monitoring of Electrical and Electronic Components of Wind Turbines
- RP 832 Lighting Protection System Condition Based Monitoring

Chapter Nine: Quality Assurance

- RP 901 Quality During Wind Project Construction
- RP 902 Lean In an Operational Environment

Chapter 1 Gearbox



Operations and Maintenance
Recommended Practices

version 2013

RP 101 Wind Turbine Gear Lubricant Flushing Procedures

The following recommended practice (RP) is subject to the disclaimer at the front of this manual. It is important that users read the disclaimer before considering adoption of any portion of this recommended practice.

This recommended practice was prepared by a committee of the AWEA Operations and Maintenance (O&M) Committee.

Committee Chair: Kevin Dinwiddie, AMSOIL
Principal Author: Kevin Dinwiddie, AMSOIL
Contributing Author: Bill Herguth, Herguth Laboratory
Reviewing Committee: Ted Vasiliw, Castrol

Purpose and Scope

The scope of “Wind Turbine Gear Lubricant Flushing Procedures” addresses the proper methods of wind turbine gearbox flushing and oil conversion procedures to optimize oil change quality and prevent carryover of additives sludge and debris from used oil to new oil.

There are numerous wind turbine gear lubricant oil system types, however this paper will focus on a commonly used lubrication system. The general procedures can easily be adapted to other lubrication systems with similar results. Base oil types associated with this Recommended Practice are Polyalphaolefin (PAO) and Petroleum oil (mineral oil). Other base oil types are not associated with this paper.

Introduction

Sludging on internal wind turbine gearbox components is common. If these components are not cleaned or flushed properly during an oil change, the quality of the new gear lubricant is compromised causing poor future performance.

Simply draining and filling a wind turbine gearbox may not be adequate. Doing so might leave deposits which could cause new oil foaming, increased wear such as micropitting, shortened oil life, and make oil analysis difficult to interpret due to used gear lubricant additive carryover into the fresh gear lubricant. Specific flushing procedures are required to optimize oil change gear lubricant quality.

Flushing Procedures

1. Preparing the Gearbox for the Oil Change

1.1. Take an oil sample of the current used gear lubricant from the gear box at the recommended location, following established sampling procedures. All samples should be taken from the same location consistently. Purge the oil sample port to ensure respective sample is taken.

1.2. A cleaner may be added to loosen up dirty or sludgy gearbox deposits and assist in the flushing process. Consult with the oil supplier for direction as to the specific type and proper usage of cleaner.

2. Draining the Used Gear Lubricant from the Gearbox

2.1. Take an oil sample.

2.2. Fabricate a drain plug with the correct fitting to adapt to a drain hose. (See *Figure A*)



Figure A

2.3. Connect the used oil hose to the reservoir drain valve.

2.4. Connect this hose to the waste oil tank at the lube truck.

2.5. Start draining the gearbox oil by opening the valve. Draining of used oil is aided by using a pump, vacuum, or both.

2.6. Open the oil filter housing, discard the used oil filter, and thoroughly drain the filter housing.

2.7. Clean the inside of the filter housing by hand. (See Figure B)



Figure B

2.8. Remove the by-pass pressure release valve and hose next to the gearbox heat exchanger/cooler and drain any oil in the hose. (See Figure C)



Figure C

2.9. Clean the by-pass pressure release valve by hand with spray cleaner (i.e. Brake Clean).

2.10. Re-install the by-pass pressure release valve and hose next to the gearbox heat exchanger.

2.11. Remove the thermostatic by-pass valve block which is found on the bottom of the filter housing and clean by hand. (See *Figure D*) Then remove the thermostat assembly from the thermostat block and clean. (See *Figure E*)

CAUTION: Do not remove the brass pin from the thermostat barrel.

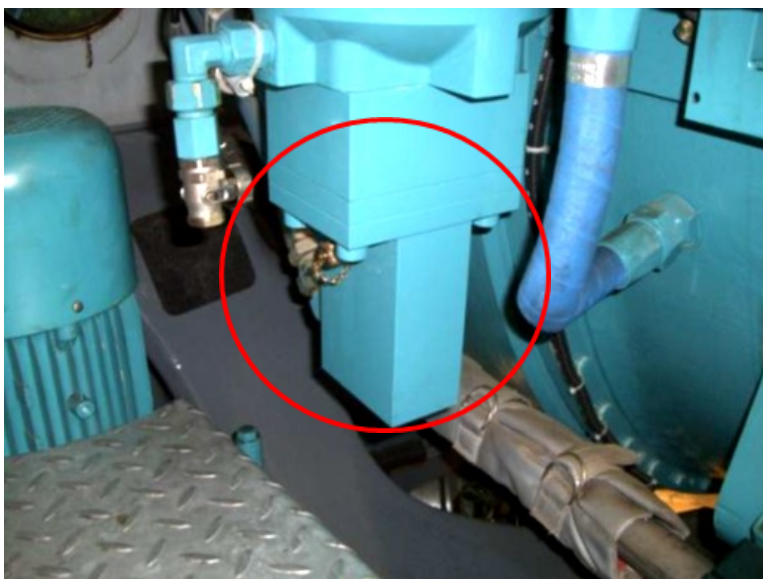

Figure D



Figure E

2.12. Re-install the thermostatic by-pass valve assembly and block.

2.13. Remove the hose from the system relief valve located between the filter housing and oil pump and drain any oil from the hose. (See *Figure F*)

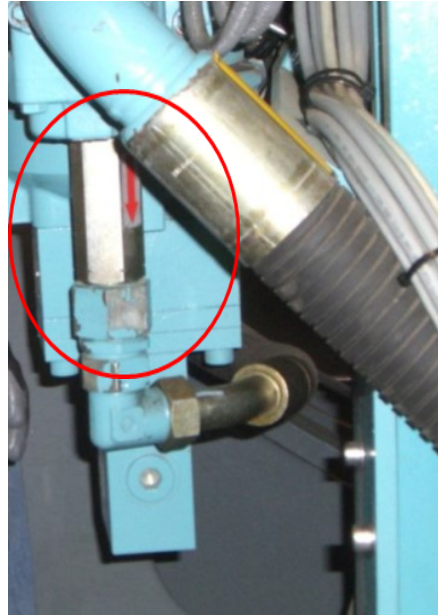

Figure F

2.14. Remove the system relief valve and clean if needed.

2.15. Re-install the relief valve.

2.16. Remove the 2-inch plug at the top of the gearbox planetary. (See *Figure G*) Purge/spray the gearbox planetary with approximately 5 gallons of new gear lube.



Figure G

2.17. Re-install the 2-inch plug at the top of the gearbox planetary.

2.18. Continue to drain the oil from the gearbox.

2.19. Through the gearbox inspection cover (See *Figure H*), purge/spray the interior gearbox housing, gears, bearings, and shafts using 5-gallons of new gear lubricant.

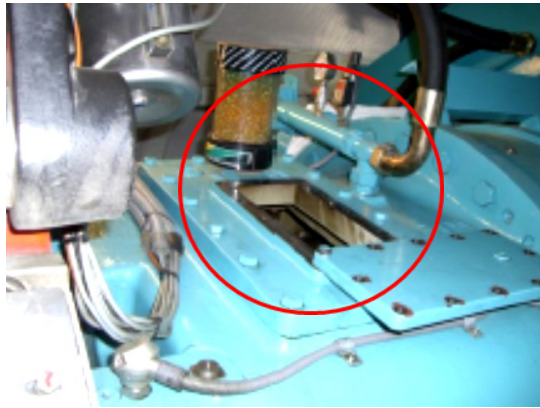

Figure H

2.20. Continue to drain the oil from the gearbox.

2.21. Close the gearbox drain valve.

2.22. Place a drain pan under the gearbox drain valve and open the valve.

2.23. Use a magnet to swab the gearbox through the drain port for any metallic wear debris.

2.24. Reconnect the hose to the drain port and open the drain valve.

2.25. Drain the external heater, if so equipped. (See *Figure I*)

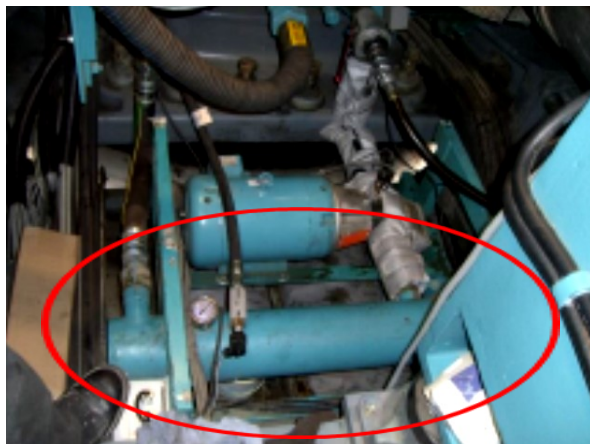

Figure I

2.26. Disconnect the oil level sensor and clean.

2.27 Take the top of the oil float level housing off and clean out the sensor housing and oil float indicator by hand. (See *Figures J and K*)

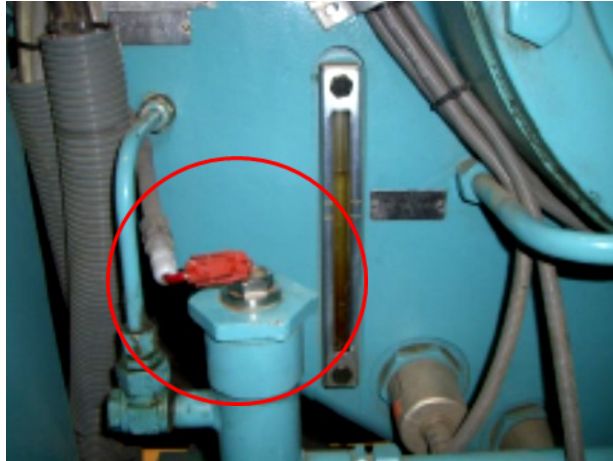

Figure J



Figure K

2.28. Install a new gasket for the oil sensor container.

2.29 Re-install the oil level sensor.

2.30. Install a dedicated flush filter. This flush filter can be reused for up to 5 turbine oil changes during the flush and rinse phases only.

2.31. Re-install the gearbox inspection cover.

3. Flushing Phase

- 3.1. Prior to flushing the gearbox, all oils located on the oil change truck/trailer need to be filtered with a 5 micron filter to keep any possible debris from the lube truck tanks or oil transfer from entering the gearbox.
- 3.2. Close the gearbox drain valve.
- 3.3. Fill the gearbox to the recommended oil level with gear lubricant.
- 3.4. Turn on the heater pump to circulate the oil in the heater sump, if so equipped.
- 3.5. Turn on the gearbox lubrication pump and let the turbine pinwheel for up to 60 minutes at low speed. This is to be done with NO Load.
- 3.6. Take a one-quart sample of gear lubricant from the gearbox and label *Flush Sample*, and include turbine number and date on the bottle.
- 3.7. Repeat Steps 2.5 through 2.31 from “*Draining the Used Gear Lubricant in the Gearbox*” section of this document. Re-clean the bypass pressure release valve, the thermostatic bypass valve block, the system relief valve, and the oil level sensor only as required.

4. Rinsing Phase

- 4.1. Prior to rinsing the gearbox, all oils located on the oil change truck/trailer need to be filtered with a 5 micron filter to keep any possible debris from the lube truck tanks or oil transfer from entering the gearbox.
- 4.2. Close the gearbox drain valve.
- 4.3. Fill the gearbox to the recommended oil level with gear lubricant.
- 4.4. Turn on the heater pump to circulate the oil in the heater sump, if so equipped.
- 4.5. Turn on the gearbox lubrication pump and let the turbine pinwheel for up to 30 minutes at low speed. This is to be done with NO Load.
- 4.6. Take a one-quart sample of gear lubricant from the gearbox and label *Rinse Sample*. Include turbine number and date on the bottle.
 - 4.6.1. Repeat Step 3.7. Close the gearbox drain valve.
 - 4.6.2. EXCEPTION FROM Step 2.29: Install new gear lubricant filter for final fill phase. Retain flush filter for re-use up to 5 times.

5. Final Fill Phase

- 5.1.** Close the gearbox drain valve.
- 5.2.** Pump up new, filtered gear lubricant until the gearbox sump reservoir is full as indicated by the gearbox sight glass.
- 5.3.** Install a new desiccant filter/breather.
- 5.4.** Inspect the gearbox inspection cover gasket and replace if necessary.
- 5.5.** Turn heater pump and lube oil pump on to circulate gear lubricant throughout the system. Turn off pumps and re-check the oil level to ensure oil level is between the low and high-level indicators. Top up as needed.
- 5.6.** Turn on the gearbox lubrication pump and let the turbine pinwheel for 15 minutes at low speed and with NO Load.
- 5.7.** Take a one-quart oil sample and label *Final Fill* and include turbine number and date on the bottle. Check for oil leaks at all fittings and connections.
- 5.8.** Check the oil level 30 minutes after shutting the turbine down to ensure the gearbox oil is at full indicator.
- 5.9.** Clean up and affix new oil label on the gearbox.

Summary

Some wind turbine gearboxes are particularly dirty from deposits left by specific gear lubricant breakdown and/or outside contaminants. It is important to understand that a good flushing process includes draining the gearbox and all associated areas. These areas include: hoses, thermostat, oil float indicator, check valves, heater, and cooler. Neglecting to address all of these areas that are known to hold old contaminated gear lubricant will result in diminished new oil quality. It is also very important to manually clean all sludged surfaces such as: filter housing, check valves, oil float indicator, and thermostat. This is to assure that contaminants are not carried over to the new gear lubricant.

Summary

(continued)

By evaluating oil analysis comparisons between the used gear lubricants, flush, rinse and final fill gear lubricant samples, it is possible to determine final fill gear lubricant quality. The oil analysis used to properly evaluate the gear lubricant samples should include:

- Viscosity
- List of items
- ICP Analysis
- Water PPM
- Particle Counting
- Foam testing

Foaming is not normally tracked during regular oil analysis; however, during the flushing procedures it is important to understand that residual components left from the used oil can cause foaming in the new gear lubricant. Although additive concentrations in the used gear lubricant are normally flushed adequately by the end of the Flush Phase, foam values may still remain and show up in oil analysis until after the Rinse Phase. This indicates that the Rinse Phase is necessary and provides a better final fill gear lubricant quality.

RP 102 Wind Turbine Gearbox Oil Sampling Procedures

The following recommended practice (RP) is subject to the disclaimer at the front of this manual. It is important that users read the disclaimer before considering adoption of any portion of this recommended practice.

This recommended practice was prepared by a committee of the AWEA Operations and Maintenance (O&M) Committee.

Committee Chairs:

Kevin Dinwiddie, AMSOIL

Erik Smith, Moventas

Principal Authors:

Eric Ryan, H&N Electric;

Kurt Swaggert, AMSOIL

Purpose and Scope

The scope of “Wind Turbine Gearbox Oil Sampling Procedures” addresses the methods for taking clean and respective wind turbine gearbox oil samples. Samples that are taken properly will provide the user with accurate data.

The general procedure applies to wind turbine lubrication systems. There are several different wind turbine gearboxes and lubrication systems. This paper will focus on two commonly used systems. These recommendations will give proper procedure for the handling of containers and oil before and after samples have been taken to ensure that data obtained from oil analysis is accurate.

Introduction

Standardizing oil analysis from a specific sampling port is important. Taking samples from different ports may result in providing skewed samples to the laboratory for analysis.

Taking respective oil analysis samples from the same port on each turbine can provide data to wind turbine personnel that will allow accurate comparisons between turbines. Establishing which turbines should be scheduled for maintenance can then be easily assessed.

Gearbox Oil Sampling Procedures

1. Preparing for Oil Sampling

1.1. Normal samples are typically taken in 3.5oz bottles. If extra laboratory tests are required taking a 1-quart sample may be required.

1.2. Oil samples should be placed in a clean unbreakable container. Oil manufacturers and analysis laboratories carry special bottles available upon request.

1.3. Before sampling, bottles must be clearly marked by labeling with the following information:

- Company/Site Name
- Turbine Number
- Gearbox Model/Type
- Oil Manufacturer
- Oil Name
- Date Sampled
- Time Sampled

Labeling ensures oil analysis is associated with the correct oil sample for data tracking purposes.

2. Prior to Taking the Gearbox Oil Sample

2.1. If the turbine has been running, turn the oil pump on for 1-minute before taking an oil sample. If the turbine has not been running make sure to activate the oil pump for a minimum of 5 minutes before taking an oil sample.

2.2. Make sure tubes, bottles, sample ports, and hoses are free of debris before taking the sample. This ensures no residual contaminants enter your sample.

2.3. Oil samples must be taken from a port before the oil filter. Samples must be taken from the same location each time to create a solid comparison. On all systems, only take samples from the recommended locations. (See *Figures A & B*)

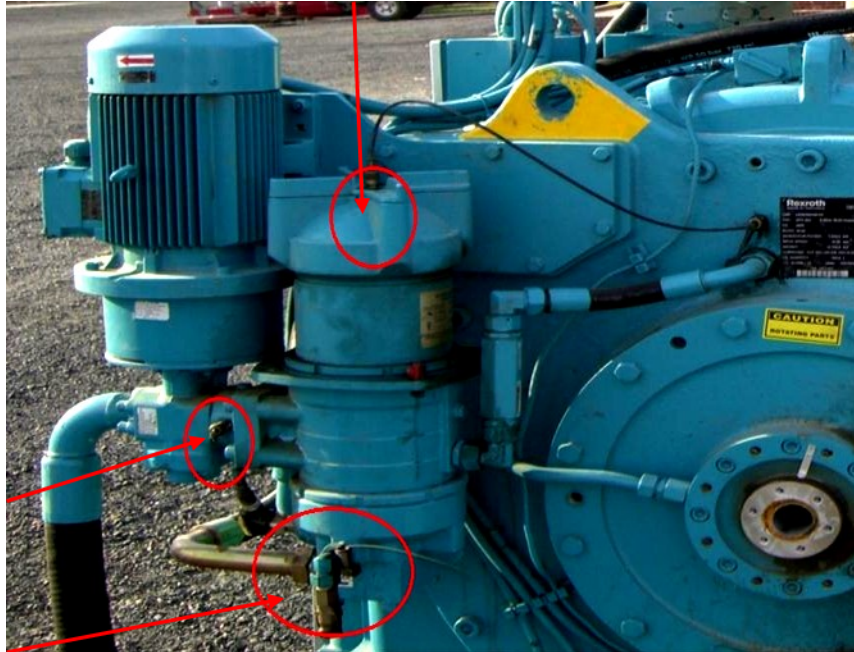

Figure A

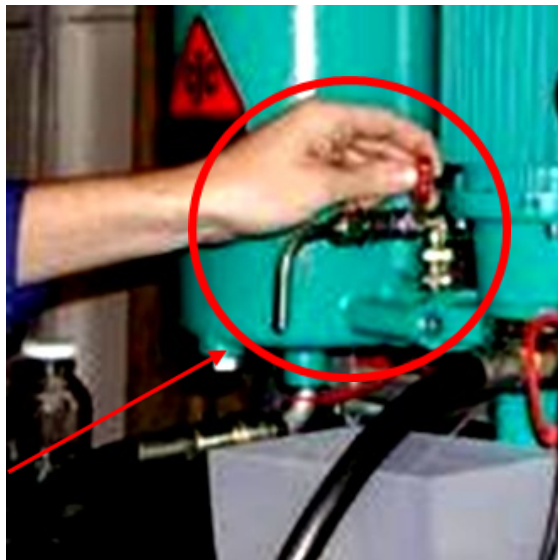

Figure B

3. Taking The Oil Sample (System 1)

- 3.1. Purge with approximately the same amount of oil as the sample bottle size from a recommended sampling port. (See *Figure A*)
- 3.2. After purge sample is drawn, seal the bottle immediately.



Figure C

- 3.3. Open the clean sample bottle when ready to take the sample.
- 3.4. Open the clean bottle and place under sample port. Make sure the bottle is not touching the sample port.
- 3.5. Fill the 3.5oz clean bottle 80-90% full and place the cap on the bottle immediately.
- 3.6. Replace any hoses or caps on oiling system to ensure no leakage before exiting.

4. Taking The Oil Sample (System 2)

4.1. Open and close the recommended sampling port valve several times to purge the system, draining the purge oil into a container. Purge with approximately the same amount of oil as the sample bottle size. (See *Figure B*)

4.2. After purge sample is drawn seal the bottle immediately.



Figure D

4.3. Open the clean sample bottle when ready to take the sample.

4.4. Open clean sample bottle and place under the sample port. Make sure bottle is not touching the sample port.

4.5. Fill the 3.5oz clean bottle 80-90% full and place the cap on the bottle immediately.

4.6. Shut off valve and ensure there are no leaks before exiting.

Summary

Proper gearbox oil sampling methods are crucial for comparing samples from one turbine to another or from sample to sample in the same turbine. This will assist in properly scheduling maintenance, as a good track record will be established. Many gearboxes have different filtration systems and sampling methods, however taking a clean sample from the same port will provide a good respective sample on a consistent basis.

RP 105 Factors Indicating Gear Lube Oil Change

The following recommended practice (RP) is subject to the disclaimer at the front of this manual. It is important that users read the disclaimer before considering adoption of any portion of this recommended practice.

This recommended practice was prepared by a committee of the AWEA Operations and Maintenance (O&M) Committee.

Committee Chair: Kevin Dinwiddie, AMSOIL
Principal Author: Kevin Dinwiddie, AMSOIL

Purpose and Scope

The scope of “Factors Indicating Gear Lube Oil Change” addresses the determining factors that could indicate a gear lube oil change is required.

Introduction

There are many factors that could cause an oil change in a wind turbine gearbox. This paper will provide factors to consider that contribute to a condition-based gear oil change. The decision to perform a condition-based oil change is founded on the overall condition of the oil which is evaluated using turbine and gearbox manufacturer condemning limits and industry standards. In some cases, filtration or dehydration corrective actions may be employed to extend the service life of the oil.

Factors Indicating Gear Lube Oil Change

1. Contamination

1.1. Externally Generated Contamination

External contamination particles can be derived from the environment or incompatible substances added to the oil. These include ingress of water due to weather conditions and natural aspiration through a breather, or salt spray, sand, dirt, dust, clay, silicates, and incompatible lubricants. Some contaminants may react adversely with oil additive packages in the lubricant, thus damaging lubricant quality and may not be able to be remedied by filtration and may even require a system flush.

1. Contamination

(continued)

1.2. Internally Generated Contamination

In some cases internally generated contaminants have the same characteristics as the external type. Internally generated contamination consists of wear debris particles, decomposition sludge, and oxidation by-products.

2. Lubricant Degradation

Additive degradation, in some cases is known as additive depletion. Some lubricant types may have slightly reduced additives while staying within acceptable limits and are still serviceable. Other lubricant types may be characterized by the reduced ability of the oil's additive system to perform its intended function. Once depleted, organic acids may form, creating sediment, sludge, or varnish particles that can cause deposits and increase the viscosity of the oil, makeup oil, or even after an oil change if not flushed properly.

3. General Guidelines For Lube Oil Changes

By necessity these guidelines are general in nature. These limits and/or rules cannot cover every conceivable situation, but are meant to be a guide for you to make cost effective and reasonable corrective actions. These guidelines are consistent with *ANSI/AGMA/AWEA 6006-A03, Standard for Design and Specification of Gearboxes for Wind Turbines* or *IEC ISO 61400-4-2012*.

3.1. Water Contamination

Water is always present in some minute amount. There are different phases for water in oil:

1. In solution (not visible to the unaided eye).
2. Emulsified (causing the oil to appear hazy or milky).
3. Free (settling on the bottom of the gear case or sample bottle).

Different phases are dependent on several factors such as oil and additive types, amount of water present, and the temperature of the oil when it is observed

AWEA 6006-A03 outlines water levels at 500 ppm (0.05%) as borderline and 1000 ppm (0.10%) as unsatisfactory^[1, Tab. F.4], however water saturation levels change with temperature fluctuations, i.e. warm oil holds more water than cold oil. This means that water in solution at hot temperature could cause some water to become free water when the oil cools from turbine down time. Water levels change with season and climate making it important to use the AWEA recommended ASTM test method, *D6304-C* outlined in the AWEA recommended practice "*Wind Turbine Gear Oil Analysis Test Methods*".

3.1. Water Contamination (continued)

Water at elevated parts per million may contribute to^[1, Tab. F.4]:

- Accelerated additive depletion
- Accelerated oxidation
- Interfere with an active lubricant film formation
- May react with additives to form residue on critical surfaces and plug filters or clog spray nozzles
- May react with the base fluid or additives to promote the hardening of elastomers or premature failure of internal coatings such as paints
- May react with base fluid where additives can increase acidity
- Direct contact with metal surfaces can produce rust particles that contribute to abrasive wear and act as an oxidation catalyst
- Corrosion etch pits may initiate fatigue cracks
- Under specific conditions, may lead to hydrogen embrittlement that promotes propagation of fatigue cracks

Bearing manufacturers and engineers have studied the effects that water in oil has on bearing fatigue and gear life and determined that increased water levels in wind turbine gear oil is related to increased gear wear and bearing fatigue life. A bearing manufacturer's research test provides data indicating water greater than 100 ppm (0.01%) will reduce bearing life significantly.^[2,3] Another example of water in oil research is referred to as the Cantley Formula.^[2,3] (See *Figure A*)

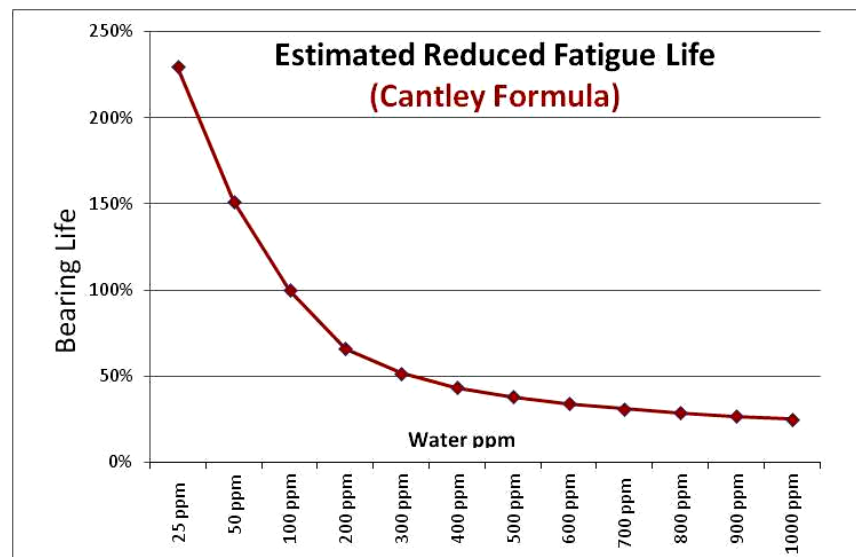

Figure A

3.1. Water Contamination

(continued)

Cantley Formula

$$L = (100/X)^{0.6}$$

X = PPM Water

L = % of Rated Bearing Life

The Cantley Formula water chart indicates that 100 ppm water in gear oil will result in 100% bearing life. It is important to keep water levels down as low as possible to optimize bearing life.

Excessive water in wind turbine gear oil has been associated with gearbox problems such as sludging, micropitting, filter plugging, and short oil and gearbox life^[1, Sec. F5.3.3.2]. The IEC/ISO committee in late 2012 published the newest wind turbine standards document *IEC 61400-4-2012* which indicates lower water limit guidelines, <300 acceptable, 300 to 600 caution level, and >600 Alarm level^[7, Tab. E.7], which are lower than *AWEA 6006-A03* water limits.

3.2. Particulate Levels

Particle counting for gear oil in wind turbines gearboxes is performed at laboratories by *Solid Contamination Code, ISO 4406-1999*. Particles are counted in three ranges: >4, >6, and >14 micron particle sizes, and the results are reported as x/x/x cleanliness code. Most turbine manufacturers consider that normal or target cleanliness code is -/16/13 and borderline levels are -/17/14, while levels of -/18/15 or greater are considered unsatisfactory.

Filtration has much to do with particle count. The >4 micron particle count will be reduced if the filtration is switched from the standard 10 micron filter to a 5 micron filter.

If improved filtration or installation of a new filter does not control particle contamination to the target level, this would be a condemning limit for the gear oil.

3.3. Sediment, Sludge, and Varnish Levels

Any visible sediment or discoloration is cause for unsatisfactory oil condition^[1, Tab. F.4]. Verify that a clean sample is taken and visible sediment is not from the sampling process. If it is confirmed that the sample was taken without debris contamination then the source of the sediment could be from the gear oil. The source and type of contamination will determine what reasonable corrective action should take place.

3.4. Total Acid Number Values (TAN)

Although general limits for TAN level increase above new gear oil values and vary by product chemistry type, lubricant suppliers should be able to give guidance regarding the level of TAN increase specific to their individual gear oil and at what point they consider recommending corrective action which could include changing the oil. General industry condemning limits are 2.0 over new oil value.

3.5. Viscosity Levels

The viscosity of the oil can change either up or down. The viscosity of wind turbine gear oil is normally 320 mm²/sec, formerly centistokes (cSt), which is referred to as ISO VG 320. Per the standard, each viscosity grade ranges + or – 10%. Thus for an ISO 320 fluid, the range would be 288 to 352 cSt. Results that fall outside of this range, either high or low, would not meet turbine or gearbox manufacturer's viscosity requirements and could result in a recommendation for corrective actions or oil change.

3.6. Foam Tendency

One laboratory test not normally done on wind turbine gear oils during the regular 6-month oil sampling period is the ASTM D892 foam test. Foaming can cause many issues from filter plugging to reduced oil film thickness. In this test air is blown into the test gear oil to create foam which builds up on top of the oil.^[3,4] Foaming is measured at the end of the test and after a 10 minute settle time. If the foam bubbles break within the 10 minute settle time, the fluid is considered to have good foaming resistance; however, if there is any foam after the 10 minute settle time then the fluid may not be performing as designed and the oil may need to be targeted for an oil change.

4. Oil Change Condemning Limits

The factors indicating a gear oil change in Table B are general and not necessarily specific to any one gear oil. (*See Table B*) It is important to contact the oil manufacturer and ask for their specific condemning limits. These condemning limits can be used as a guide in determining when an oil change is needed.

Table B: Factors Indicating Gear Lube Oil Change

| | Method | Measure | Monitor | Change or Reconditioning |
|------------------------------|------------------------------|----------------------------|--------------------|---------------------------|
| Water | Water ASTM D6304-C | ppm | 300 to 600 | 600 |
| Foam (@10 min settle) | ASTM D892 | ml | <10 | >10 |
| Particulate Levels | Cleanliness Code | >4/>6/>14 | -/17/14 | -18/15 |
| Total Acid Number | ASTM D664 | mg/g KOH | 1.5 over new | 2.0 over new |
| Viscosity | STM D445 | mm ² /sec (cSt) | <304 or >336 | <288 or >352 |
| Sediment | Visual in oil sample | | | Any |
| Sludge or Varnish | Visual | N/A | N/A | Early filter replacements |
| Additive | ICP or AES oil analysis ASTM | | Subject to Oil Mfg | Subject to Oil Mfg |
| Depletion | D5185 or ASTM D6595 | | Condemning limits | Condemning limits |

Summary

Increased contaminants, change in lubricant physicals, and additive depletion are what to look for when evaluating whether or not gear oils need to be condemned and changed out. It is extremely important to obtain the condemning limits of the oil in use from the oil manufacturer. Applying the wrong condemning limit will cause inaccurate evaluation and skew the decision for condemning.

References

[1] *Design and Specification of Gearboxes for Wind Turbines*, ANSI/AGMA/AWEA 6006-A03 (R2010), 2010.

[2] *Timken Engineering Manual*, Timken, North Canton, Ohio, USA, 2017.

[3] *Timken Products Catalog*, Timken, North Canton, Ohio, USA, 2017, pp. A146.

[4] R. E. Cantley, "The Effect of Water in Lubricating Oil on Bearing Fatigue Life," *ASLE Trans*, vol. 20, no. 3, pp. 244-248, 1977.

[5] fluidlife.com. "The Impact of Water Contamination on Lubricants," 2017. [Online]. 5] Available: <http://www.fluidlife.com/2017/04/16/the-impact-of-water-contamination-on-lubricants/>.

[6] *Standard Test Method for Foaming Characteristics of Lubrication Oils*, ASTM D892-06, 2006.

References
(continued)

- [7] *Wind Turbines -- Part 4: Design Requirements for Wind Turbine Gearboxes*, ISO IEC 64100-4:2012, 2012.

RP 106 Wind Turbine Gear Oil Filtration Procedures

The following recommended practice (RP) is subject to the disclaimer at the front of this manual. It is important that users read the disclaimer before considering adoption of any portion of this recommended practice.

This recommended practice was prepared by a committee of the AWEA Operations and Maintenance (O&M) Committee.

Committee Chair: Kevin Dinwiddie, AMSOIL
Principal Author: Bill Needleman, Donaldson
Contributing Author: Megan Santos, Hydac

Purpose and Scope

The scope of “Wind Turbine Gear Oil Filtration Procedures” addresses full-flow gear oil filters installed in wind turbine gearboxes. Flushing filters and off-line (a.k.a. kidney loop) filters that may also be used with these gearboxes are defined but not discussed further in this recommended practice. Water and other types of contaminants are not discussed in this practice.

Introduction

Full-flow filters are used to protect gearbox mechanical components from particle contamination suspended in gear oil. The major sources and types of particle contamination, along with associated wear mechanisms, are compiled in *Table A*. (See *Table A*) The most contaminant sensitive gearbox components are bearings, followed by dynamic seals, pumps, and gears. One study by Timken established gear tooth wear debris as causing the greatest damage to rolling bearings^[1]. In a second study, NASA found increases in rolling bearing life up to 6 times with increasing oil cleanliness maintained with highly efficient filters^[2].

Table A: Damaging Contaminant Particles Found in Wind Turbine Gear Oil.

| Sources/Ingression | Types | Wear Mechanisms |
|--|--|--|
| airborne mineral dusts | vents, ports, seals | sliding contact abrasion in gears, seals, pumps, retainers |
| metallic wear debris | gear tooth wear | rolling contact fatigue leading to pitting, spalling |
| manufacturing swarf: polishing/lapping grits, metallic chips | new installations, replacement parts | early failures of bearings, pumps, seals, gears |
| salt | marine sea spray followed by airborne ingression | corrosion |

Full-Flow Gear Oil Filter Procedures

1. Target Particle Contamination Levels

In order to minimize damage to gearbox components, it is recommended that gear oil be maintained at or above specified levels of cleanliness. Quantities of particle contamination measured in oil samples are typically reported according to ISO 4406^[3]. This format reports the number of particles per milliliter equal to or greater than a given size in micrometers (µm). Particles per milliliter greater than 3 sizes are reported:

- 1 ≥ 4 µm
- 2 ≥ 6 µm
- 3 ≥ 14 µm

The number of particles for each size range is reported as an ‘ISO Code’. For example, the number of particles in a particular sample of gear oil is reported as: ISO 19/17/15.

This translates to:

- 19: 2500-5000 particles/mL ≥ 4 µm in size
- 17: 640-1300 particles/mL ≥ 6 µm
- 15: 160-320 particles/mL ≥ 14 µm

1. Target Particle Contamination Levels (continued)

An increase of one ISO Code equates to an increase in particle contamination by a factor of 2. As a second example, an oil sample with an ISO Code of 20/18/16 has in each size range two times more particles than the previous example. Maximum particle contamination levels are specified by gearbox or turbine manufacturer, or by in-house specification. Table 17 of *ANSI/AGMA/AWEA 6006-A03*^[4], (See *Table B*), suggests a set of maximum allowable contamination levels for wind turbine gearboxes. Turbine or gearbox OEM, or in-house specifications, take precedence over this table.

Table B: Lubricant Cleanliness

| Source of Oil Sample | Required Cleanliness Per ISO 4406 |
|---|-----------------------------------|
| Oil added into gearbox at any location | - / 14 / 11 |
| Bulk oil from gearbox after factory test at the gearbox manufacturer's facility | - / 15 / 12 |
| Bulk oil from gearbox after having been in service 24 to 72 hours after commissioning of the WTGS (pressure fed systems only) | - / 15 / 12 |
| Bulk oil from gearbox sampled per the operating and maintenance manual (pressure fed systems only) (See Step 6.7.) | - / 16 / 13 |

Particle contamination in operating systems may be monitored by two alternative approaches:

This translates to:

- Periodic oil samples are obtained from the gearbox then sent to a laboratory for analysis. This is the method currently used by a large majority of operators.
- An on-line particle counting unit mounted on the gearbox. This has the advantage of providing real-time data. Disadvantages are unit and installation costs and maintenance.

2. Selecting Full Flow Gear Oil Filters

2.1. Definitions

2.1.1. Full-flow filters receive the total flow of lubricant produced by the main lubrication system pump(s). All suspended particles in the oil reservoir are carried by the flowing gear oil into these filters. Depending on filter efficiency (filter rating), many to most damaging particles are removed from the gear oil by the full-flow filter before reaching loaded mechanical components, especially bearings and gears.

2.1.2. Off-line filtration systems are designed to operate independently of, or in addition to, the full flow filtration system. Off-line filtration may be used to supplement contaminant removal by full-flow filters, if deemed necessary to meet specified cleanliness levels.

2.1.3. Flushing filters are used to clean a gearbox during an oil change or after a system upset. These filters are temporarily plumbed into the gearbox lubricant system, and removed when the clean-up is completed. Flushing filter ratings should be as good as or greater than the full-flow filters installed on the gearbox.

2.2. Full-Flow Filter Ratings

The function of a full-flow filter is to remove damaging particles from the lubricant. For modern industrial filters, particle removal efficiency (a.k.a. filter efficiency) is reported as a 'filter rating'. Examples are filters rated at 5 μm or 10 μm . For particles this size and larger the filter is extremely efficient, as determined and quantified by laboratory testing. As illustrated in Figure A, filter efficiency is determined by ISO 16889^[6]. (See *Figure A*)

2.2.1. The procedure is performed under controlled laboratory conditions.

2.2.2. A slurry of test dust (finely powered silica sand) in oil is flowed into the filter.

2.2.3. The number of particles entering and leaving the filter are sized and quantified throughout the test using electronic particle counters.

2.2.4. Filter ratings are reported as beta ratios:
 $\beta_{10(C)} = \text{Number Particles Upstream} \geq X \mu\text{m} \div \text{Number Particles Downstream} \geq X \mu\text{m}$.

2.2.5. For example, a filter rated at 10 μm has $\beta_{10(C)} \geq 1000$.

2.2. Full-Flow Filter Ratings (continued)

2.2.6. Not all filters are equal. For example, a filter rated at 5 μm is 20 to 50 times more efficient at removing particles than a 10 μm filter, which in turn is 20 to 50 times more efficient than a filter rated at 20 μm .

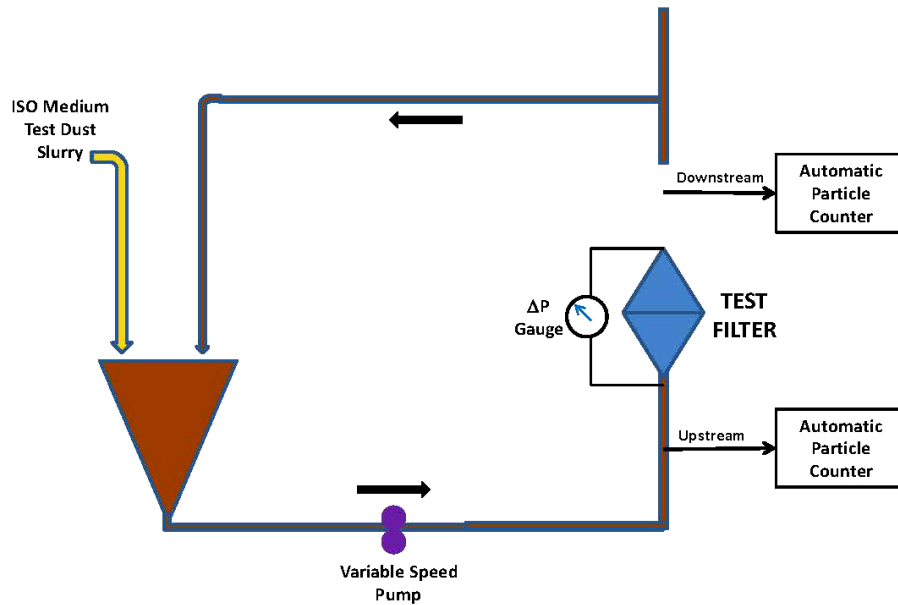

Figure A: Multipass Test Per ISO 16899

2.3. Proper Filter Performance Parameters

Several additional parameters are required to ensure proper filter performance in a gearbox:

2.3.1. Differential Pressure (ΔP)

Filters present restrictions to flow. As gear oil flows through the filter, differential pressure (ΔP) develops across the filter. Differential pressure increases with increasing flow rate and oil viscosity. Cold gear oil flowing through a filter, such as during a system cold-start, often produces the greatest differential pressure experienced by full-flow filters. A maximum differential pressure may be specified by the gearbox or turbine OEM for unused filters at specific flow rates, oil types, and temperatures.

2.3. Proper Filter Performance Parameters

(continued)

2.3.2 Compatibility and Integrity

The full-flow filter must be able to maintain integrity and withstand maximum differential pressure, including during cold-start, after contacting gear oil at highest system temperature. For additional information, see ISO 2941, “*Verification of Collapse Burst Pressure Rating*”, and ISO 2943, “*Filter Elements - Verification of Material Compatibility with Fluids*”.

2.3.3. Filter Service Life

As filters capture and retain particles, flow restriction and differential pressure increases. Full-flow filters are changed at or before a maximum differential pressure is reached. This ΔP value is specified by the gearbox or turbine manufacturer. The time interval between installation and removal is termed the filter service life. The ISO 16889 Multipass Test measures dirt holding capacity of silica sand under controlled conditions. However, because different types of contaminants load filters during field operation, this test method may not accurately predict the service life of full-flow filters in wind turbine gearboxes. It is recommended service life be established by field experience and evaluations.

2.4. Selecting a Full-Flow Filter

The full-flow filter should meet or exceed the specifications of the gearbox and/or turbine manufacturer. The filter rating should be sufficient to meet or exceed target cleanliness levels under real-world operating conditions. For concerns with possible removal of additives, confer with the oil supplier.

3. Changing Spent Gear Oil Filters

Two strategies are used for changing spent full-flow filters. The strategy used at a specific site may be specified by the gearbox or turbine manufacture, or by an in-house specification.

3.1. On-Time

This is the strategy used by the majority of wind turbine operators. Full-flow filters are changed at a convenient service interval. Currently, the most common service interval for land-based turbines is 6 months. Because filters are expected to last a minimum of 6 months, many are changed before dirt holding capacity has been depleted.

3. Changing Spent Gear Oil Filters (continued)

3.2. On-Condition

Full-flow filters are changed when a differential pressure indicator signals a pre-determined value of ΔP . This change-out ΔP is set below the differential pressure that activates the by-pass valve, avoiding unfiltered lubricant passing into the gearbox. Because the maximum dirt-holding capacity of the filter is used, this method tends to increase filter change-out interval length. However, tower climbs at irregular intervals to change these filters may be inconvenient and/or un-economical.

4. Filter Change-Out Check List

_____ 1. **Down Tower**
Inspect new filter. There should be no damage from handling/shipping.

_____ 2. **Bring Up Tower**
Plastic waste bag for used filter.
If changing spin-on filter, bring belt wrench.
2 gallons of pre-filtered make-up gear oil.

NOTE: The rating of the filter used for pre-filtering the gear oil should be at least as fine as the filter installed in the gearbox.

_____ 3. **If Changing a Cartridge Filter**
Remove cover from housing.
Partially remove used filter and let drain for several minutes.
Completely remove used filter and place in plastic waste bag.
Install new filter into housing.
Secure cover onto housing and tighten fittings.
Top up oil as needed.

_____ 4. **If Changing a Spin-On Filter**
Remove old spin-on. May need belt wrench.
Place old spin-on filter into plastic waste bag.
Spin new element onto filter head and tighten.
Top up oil as needed.

_____ 5. **When Back Down Tower**
Discard used element according to company policy.

Summary

By protecting contaminant sensitive components from harmful particles, full-flow gear oil filters are indispensable for achieving acceptable uptime and life of wind turbine gearboxes, as well as for reducing maintenance costs. The full-flow filter installed on the gearbox should meet or exceed specifications. Specifications include, but are not limited to: filter rating (particle size where $\beta X(C) \geq 1000$), differential pressure (ΔP), compatibility, and integrity. The filter should also provide an acceptable service life based on the needs of the site. A check-list is included to aid the proper change-out procedure when replacing spent filters with new filters.

References

- [1] E. V. Zaretsky and W. M. Needelman, "Recalibrated Equations for Determining Effect of Oil Filtration on Roller Bearing Life," in *STLE Proceedings 64th Annual Meeting*, Orlando, 2009.
- [2] M. Kotzalis and W. M. Needelman, "Minimizing Oil Contamination and Using Debris Resistant Bearings to Enhance Wind Turbine Gearbox Performance," in *Proceedings International Joint Tribology Conference*, Memphis, 2009.
- [3] *Hydraulic Fluid Power -- Fluids -- Method for Coding the Level of Contamination by Solid Particles*, ISO 4406:1999, 1999.
- [4] *Design and Specification of Gearboxes for Wind Turbines*, ANSI/AGMA/AWEA 6006-A03 (R2010), 2010.
- [5] *Hydraulic Fluid Power Filters -- Multi-pass Method for Evaluating Filtration Performance of a Filter Element*, ISO 16889:1999, 1999.

Chapter 2

Generator and Electrical



Operations and Maintenance
Recommended Practices

version 2017

RP 201 Generator Collector Ring Assembly Maintenance

The following recommended practice (RP) is subject to the disclaimer at the front of this manual. It is important that users read the disclaimer before considering adoption of any portion of this recommended practice.

This recommended practice was prepared by a committee of the AWEA Operations and Maintenance Working Group.

Committee Chair: Kevin Alewine, Shermco Industries

Principal Authors:

Benoit White, Mersen

Roland Roberge, Morgan AM&T

Mark Keeland, Schunk Graphite

Contributing Authors:

Kevin Alewine, Shermco Industries

Paul Kling, Morgan AM&T

Purpose and Scope

The scope for “Generator Collector Ring Assembly Maintenance” addresses the common maintenance issues related to the collector ring assembly in double fed induction generators that are commonly used in many wind turbine designs. This section is not machine specific and some variations may be required based on specific designs.

Introduction

In double fed induction generators, power is normally transferred to and from the wound rotor by the use of rotating collectors and brush assemblies. These are high wear items and should be included in any regularly scheduled maintenance inspection or process. The normal recommendation is to inspect and clean at least bi-annually, but longer maintenance cycles may be possible with improved materials and designs. Brush life is affected by carbon grade, ambient temperature, and humidity, as well as other operating environmental conditions. It is critical to the successful implementation of these procedures that good records are kept of generator maintenance and of any performance issues discovered between inspection intervals. Prior to any disassembly at each step, a careful visual inspection should be performed and any abnormal conditions should be documented, preferably including photographs.

Collector Ring Assembly Maintenance Procedures

1. Inspecting the Assembly

Remove the generator collector ring cover(s). View the general condition of the assembly. Note any build up of residue, leaking gaskets, broken or missing components, etc. A 1000 volt phase-to-phase and phase-to-ground insulation resistance test of the collector ring assembly is also suggested before and after cleaning. Caution should be used to ensure the test voltage will not damage any electronic components. Review OEM motor testing procedures. Values should conform to the generator manufacturer's specifications, but normally the minimum value should exceed 10 megaohms during service and 100 megaohms after cleaning. Leads should be disconnected before testing.

1.1. Brushes

1.1.1. Removal

To remove the brush for most designs, push forward on the spring to disengage the latch and lift the spring out of its slide. Other styles of tension devices may be used. Consult the manufacturer's specifications for a specific generator design. Pull the brush out of its holder by its cables without disconnecting it. Note the orientation of the brush to the holder to ensure the brush will properly be reinstalled if it is not to be replaced.

1.1.2. Brush Body

Inspect the brush for minimum length requirement and any unusual wear-marks and free movement of the brush in the holder noting any restriction that may be a sign of material swelling.

NOTE: This should also be a regular test for lightning protection brushes and grounding brushes.

Inspect for chipping or cracking. Assure that the terminals are secure and that shunts, micro switch tabs, etc. and rivet connection, if applicable, are in good working order and properly mounted and connected.

1.1.3. Stunt Wires

Discolored shunt wires can indicate uneven current sharing or overheating by insufficient air flow. It is recommended to replace the complete brush set because single brushes can already be damaged. If the shunts are damaged or frayed by vibration, mechanical problems, or too strong air flow, they should also be replaced and the condition corrected. Note any abnormal wear indicators. Verify terminal connections are secure on all brushes.

1.1.4. Vibration Markings

Smooth and shiny side surfaces are a clear indication of radial movement by the brushes in the brush box. This can be caused by out-of-roundness of the slip ring. Excessively high friction can also result in a shiny slip ring surface or external vibrations such as defective bearings, shafts, couplings, etc. Markings of current transfer between brush holders and brush indicate that the connection between shunt and brush body is possibly damaged. Excessive brush dust in the slip ring compartment can also cause inappropriate current transfer. Frayed shunts or markings from the springs on the brush top also indicate abnormal vibration.

1.1.5. Brush Surface

Rough brush face surfaces may be caused by brush sparking from electrical or mechanical problems, e.g. vibrations. Rough surfaces on grounding brush faces can be an indication of possible converter problems as well as ring surface issues.

Rule of thumb: If one of the brushes has to be replaced and the set is worn more than 25%, all the brushes should be replaced. If all brushes are to be replaced, disconnect them, and remove them from the assembly. Loosen the terminal bolts until the brush terminal can be slid out from underneath. If possible, do not fully remove the bolt to avoid dropping it and other hardware into the assembly.

1.2. Brush Holder

1.2.1. Holder Box

Inspect entire holder for any indications of arcing or burning damage. Verify that all hardware and electrical connections are secure. Note any abnormal wear indicators.

1.2.2. Springs

Inspect tension devices for any indications of arcing, burning, or discoloration. The spring force should be checked every year with an appropriate spring scale device and springs should be replaced every 3 to 5 years depending on the type of application. Springs with a deviation of more than 10% from the set value should be replaced.

1.2.3. Holder Distance

For a safe guidance of the brushes in the brush holder, it is normally suggested that the distance between holder and slip ring surface is no more than 3 mm (0.125”).

1.3. Collector Rings

If possible, the collector ring surface should also be checked regularly for grooving and other damage. Consult OEM specifications for tolerances. The collector ring assembly and the surrounding area should be checked for oil contamination. If oil or grease from the bearing comes into contact with the slip ring surface, an insulating film can be formed which hampers the current transfer. Increased brush wear could be the consequence. The brushes are porous and, in the case of oil contamination, all brushes should be replaced after the collector ring is cleaned.

1.3.1. Excessive TIR (Total Indicator Runout or Out-of-Round)

All collector ring assemblies are installed with round rings. After a few years of service, the collector ring can deteriorate to a TIR greater than 0.010”. This out-of-roundness cannot be seen with the naked eye. Special profilers are required to accurately measure the out-of-roundness. The out-of-roundness develops in many forms such as an oval shape, a shape with multiple lobes or a round shape that has many low spots. The textbook limit for out-of-roundness on a collector ring is 0.003”. The average wind collector ring has a 32 inch circumference.

1.3.1. Excessive TIR (Total Indicator Runout or Out-of-Round) (continued)

The suggested out-of-roundness of collector ring performance evaluation and profiling guideline is:

Not to be more than 0.001 inch out-of-roundness per 1.000 inch of travel with a maximum of 0.015" total indicator runout.

If the above criteria is met and there are no signs of brush burning and ring erosion, the collector ring be can returned to operation.

1.3.2. Grooving

Vibration and the environment can cause collector rings to wear or groove after extended periods of operation. The proper brush grade and brush springs can significantly reduce the amount of slip ring wear. The generator can be operated with a groove ring as long as the TIR is not too high and the brush remains in contact with the slip ring. A spiral groove is often machined into the collector ring. If the collector ring is worn past the spiral groove, the collector ring should be replaced.

1.3.3. Generator Shaft

The profiler mentioned in 1.3.1. can also be used to measure the shaft runout. With the slip ring removed, measure the shaft indicated runout as it turns. It is not uncommon to find that the shaft is bent. If the shaft variation exceeds 0.006 inch, you should consider contacting a skilled technician or service provider for further evaluation and correction.

1.3.4. Signs of Brush Sparking

Extreme brush sparking may cause a serious flash over. Signs of sparking can be found on the brushes, the brush boxes, the rocker rings, or other paths nearby the slip ring.

1.3.5. Brush Dust

Carbon brush dust is a good conductor. Excessive accumulation of dust, therefore, may also create flash over and must be removed regularly during the inspection. Sufficient air flow is essential for successful removal of brush dust. Filters, air tubes, etc., should therefore also be checked regularly. The complete ventilation system should be cleaned and checked for proper operation.

2. Cleaning and Reassembly

2.1. Cleaning Collector Ring Assemblies

The collector ring assembly cover(s) should be completely removed and all components inspected as above before proceeding with cleaning. For these cleaning procedures, it is suggested that appropriate personal protection devices be worn, including a dust mask.

Use a small vacuum, preferably with a HEPA type filtration system, and a non-metallic brush to remove all accumulated dust and other contaminants from the collector ring enclosure, the brush holder assemblies, any supporting rods or fixtures, and the collector ring itself. Contact cleaner or other solvents should not be used directly on the collector ring as they may drive the carbon dust deeper into the insulated area reducing the dielectric properties of the assembly. If it is necessary to use a solvent, spray the solvent on a disposable towel or cloth and use the cloth to wipe the solvent on the unclean area. Do not use solvents on carbon brushes because they could affect the carbon material. The collector ring film, or patina, should not be cleaned with a solvent. If the collector ring surface does require cleaning, only use a mild abrasive tool such as a non-conductive abrasive pad or a flexible rubber abrasive. Always clean from the top down to avoid re-contaminating components.

NOTE: If a brush is not to be replaced, it should remain connected during inspection and cleaning to assure the return to its original location.

2.2. Installing Brushes

To install new brushes or to reinstall brushes after inspection, insert the brush into the holder ensuring the proper orientation, then slide the spring clip back into its slot and push it down onto the brush until the spring clip latch clips into the retaining notch. Connect new brushes and check that the connection is tight and the terminal is located correctly under the spring washer. As a final check to assure that the brush is free to move up and down in the brush holder and that the spring clip latch is correctly fitted, pull on the brush leads and lift the brush approximately 12 mm (0.5") and then lower it back onto the slip ring a few times.

2.3. Seating New Brushes

Many new brushes are manufactured with a bottom radius. This radius is not the exact contour of the slip due to manufacturing tolerance, brush holder orientation, and slip ring wear. In order to ensure adequate electrical contact to the collector ring, the brushes must be properly seated. Poor contact at startup can lead to major performance issues, shortened brush life, and even component damage.

Garnet paper or any non-metal bearing abrasive paper is recommended and cloth backed abrasives are often easier to use in many circumstances. The abrasive size should be 80 to 120 grit. Fine sandpaper, such as 400 grit, will easily fill with carbon making the sanding process more difficult. It is important not to leave abrasive particles under the brushes when completed as these could damage the slip ring surface.

Seat one brush at a time while all the other brushes are still connected but out of their holders.

Lift the brush by its shunts and slide a strip of the abrasive cloth under it with the abrasive side of the paper facing the brush. Lower the brush down onto the abrasive cloth and place the spring in its normal engaged position. The spring should apply the pressure to the brush. Slide the garnet paper back and forth under the brush in line with the brush path. After several passes back and forth, remove the brush from its holder and check the face of the brush. The seating is complete when at least 80% of the brush face is abraded. Vacuum out all of the accumulated carbon dust and sanding debris and reinstall the brush and spring-clips. Repeat with all new brushes or with used brushes with improper seating marks.

2.3. Seating New Brushes

(continued)

Once properly assembled, assure that all bolts are tightened and the brushes are properly connected.

Again, as a final check that the brush is free to move up and down in the brush holder and that the spring clip latch is correctly fitted, pull on the brush leads and lift the brush approximately 12 mm (0.500") and then lower it back onto the slip ring a few times.

Also, make sure that all tools and cleaning materials are removed from the area and the cover gaskets are functioning properly before replacing the cover.

RP 202 Grease Lubricated Bearing Maintenance

The following recommended practice (RP) is subject to the disclaimer at the front of this manual. It is important that users read the disclaimer before considering adoption of any portion of this recommended practice.

This recommended practice was prepared by a committee of the AWEA Operations and Maintenance (O&M) Committee.

Committee Chair: Kevin Alewine, Shermco Industries
Principal Author: Korey Greiner, SKF
Contributing Author: Kevin Alewine, Shermco Industries

Purpose and Scope

The scope of “Grease Lubricated Bearing Maintenance” addresses the common maintenance issues related to lubrication of generator bearings and a basic trouble shooting guide to help with service and repair decisions.

Introduction

Conventional utility scale wind turbine generators range from 500 kW to > 3 MW in production capabilities. Most of these units use grease lubricated anti-friction ball bearings that require some type of replenishment on a regular basis on both the drive and non-drive ends of the machine. Often, lubrication supply devices are utilized to partially automate the process, but monitoring and adjustments are required even with these automated systems. A few turbine designs have generators directly mounted to the gearbox and will only have one, non-drive end bearing to be maintained as the drive end bearing is integral to the gearbox lubrication system. Whereas alignment issues are simplified with these direct coupled machines, assuring proper lubrication is still a key element in good maintenance procedures. Alignment and vibration also contribute to premature bearing failures and those issues will be addressed in separate recommended practice documents. Regardless of design, it is critical that the proper amount of lubricant is used; both too little and too much grease will dramatically shorten the life of the bearing.

The proper choice of lubricant is normally specified by the generator manufacturer, but a general overview is included in this recommended practice for informational purposes only. Please refer to industry standard documents for more details.

Direct drive machines use generators that are integral to the main shaft of the wind turbine and the lubrication of those main bearings are discussed in other recommended practices.

Grease Lubricated Bearing Maintenance

1. Overview of Grease Lubricated Bearings

Lubricating greases usually consist of mineral or synthetic oil suspended in a thickener, with the oil typically making up 75% or more of the grease volume. Chemicals (additives) are added to the grease to achieve or enhance certain performance properties. As a result of having a thickener package, grease is more easily retained in the bearing arrangement, particularly where shafts are inclined or vertical. Grease also helps to seal bearings against solid particulate and moisture contamination. Excessive amounts of grease will cause the operating temperature in the bearing to rise rapidly, particularly when running at high speeds. As a general rule for grease lubricated bearings, the bearing should be completely filled with grease prior to start-up but the free space in the housing should only be partially filled. Before operating at full speed, the excess grease in the bearing should be allowed to settle or escape into the housing cavity during a running-in period. At the end of the running-in period, the operating temperature will drop considerably indicating that the grease has been distributed in the bearing arrangement. See the generator manufacturer's specifications for more information on running-in loads and speeds.

2. Grease Selection

When selecting grease style and manufacturer for bearing lubrication, the base oil viscosity, consistency, operating temperature range, oil bleed rate, rust inhibiting properties, and the load carrying ability are the most important factors to be considered. Please refer to the generator manufacturer's recommendations for the proper grease type for a specific machine.

3. Lubricant Compatibility

If it becomes necessary to change from one grease to another, the compatibility of the greases should be considered.

CAUTION: If incompatible greases are mixed, the resulting consistency can change significantly and bearing damage due to lubricant leakage or lubricant hardening can result.

Greases having the same thickener and similar base oils can generally be mixed without any problems, e.g. a lithium thickener/mineral oil grease can generally be mixed with another lithium thickener/mineral oil grease. Also, some greases with different thickeners, e.g. calcium complex and lithium complex greases, can be mixed. However, it is generally good practice not to mix greases.

3. Lubricant Compatibility

(continued)

The only way to be absolutely certain about the compatibility of two different greases is to perform a compatibility test with the two specific greases in question. Often the lubricant manufacturers for common industrial greases have already performed these tests and they can provide those results if requested. Most preservatives used to protect bearings are compatible with the majority of rolling bearing greases with the possible exception of older style polyurea greases. Again, always check with the generator manufacturer before changing or mixing grease types or manufacturers.

4. Lubrication

In order for a bearing to be properly lubricated with grease, oil must bleed from the grease. The oil then coats the bearing components, but is gradually broken down by oxidation or lost by evaporation, centrifugal force, etc. Over time, the remainder of the grease will oxidize or the oil in the grease near the bearing will be depleted. At this point, re-lubrication is necessary to keep the bearing operating properly for its designed life. There are two critical factors to proper lubrication: the quantity of grease supplied and the frequency at which it is supplied. Ideally, re-lubrication should occur when the condition of the existing lubricant is still satisfactory. The lubrication interval depends on many related factors. These include bearing type and size, speed, operating temperature, grease type, space around the bearing, and the bearing environment. Please refer to the generator manufacturer's documentation for lubrication rates and quantities.

4.1. Manual Lubrication Procedure

There is probably a manufacturer's recommendation regarding the hours of operation before lubrication. It is recommended that this be considered a maximum parameter since the periodic maintenance of wind turbines is normally minimized due to the difficulties of access. Make sure all fittings are clean and free from contamination. If the exit port becomes clogged or if the grease hardens within the bearing housing, the excess grease can be pushed out of the generator and onto the exterior or, more importantly, into the interior of the generator, contaminating the windings. Dispense only the amount required. Do not overfill. Refer to the generator manufacturer's specifications regarding the quantity and frequency rate for lubrication of the bearings.

4.2. Automated Lubrication

Automated lubrication devices work by adding a measured amount of grease to the bearing housing. The influx of new grease pushes out older material through an exit port. Again, if the port becomes clogged or if the grease hardens within the generator, the excess grease can be pushed out of the housing and onto the exterior or, more importantly, into the interior of the generator, contaminating the windings. Operation of these devices is critical and they should be checked carefully during periodic turbine inspections. Auxiliary power should be available for a test run of the device to assure proper operation. Also, any grease in the automated device storage container where the oil has separated should be replaced.

5. Operating Temperature

Since grease aging is accelerated with increasing temperature, it is recommended to shorten the intervals when in increased operating temperature environments. The alternate also applies for lower temperatures and the lubrication interval may be extended at temperatures below 158°F (70°C) if the temperature is not so low as to prevent the grease from bleeding oil. In general, specialty greases are required for bearing temperatures in excess of 210°F (100°C). Again, consult the generator manufacturer for grease recommendations for extreme temperature conditions.

6. Vibration

Moderate vibration should not have a negative effect on grease life. But high vibration and shock levels, such as those in found in wind turbines, can cause the grease to separate more quickly, resulting in churning of the oils and thickener. In these cases the re-lubrication interval should be reduced. The overall importance of testing and controlling vibration is covered in another recommended practice.

7. Contamination

Contaminants have a very detrimental effect on the bearing surfaces. More frequent lubrication than indicated by the manufacturer's recommended interval will reduce the negative effects of foreign particles on the grease while reducing the mechanical damaging effects. Fluid contaminants (water, oil, hydraulic fluids, etc.) also call for a reduced interval. Since there are no formulas to determine the frequency of lubrication because of contamination, experience is the best indicator the appropriate interval. It is generally accepted that the more frequent the lubrication the better. However, care should be taken to avoid over-greasing a bearing in an attempt to flush out contaminated grease. Using less grease on a more frequent basis rather than the full amount of grease each time is recommended. Excessive greasing without the ability to purge will cause higher operating temperatures because of churning.

Summary

This recommended practice is designed to provide basic information and techniques for proper lubrication of generator bearings as well as a troubleshooting guide to aid with maintenance and repair decisions. Proper care and lubrication, when required, will assure long, trouble free service life for these critical components.

Troubleshooting Guide

Bearings that are not operating properly usually exhibit identifiable symptoms. This section presents some useful hints to help identify the most common causes of these symptoms as well as practical solutions wherever possible. Depending on the degree of bearing damage, some symptoms may be misleading. To effectively troubleshoot bearing problems, it is necessary to analyze the symptoms according to those first observed in the applications. Symptoms of bearing trouble can usually be reduced to a few classifications, which are listed below.

Note: Troubleshooting information shown on these pages should be used as guidelines only.

1. Common Bearing Symptoms

- Excessive heat
- Excessive noise
- Excessive vibration
- Excessive shaft movement
- Excessive torque to rotate shaft

2. Excessive Heat

2.1. Lubrication

- Wrong type of lubricant
- Insufficient lubrication - too little grease
- Excessive lubrication - too much grease without a chance to purge

2.2. Insufficient Bearing Internal Clearance

- Wrong bearing internal clearance selection
- Excessive shaft interference fit or oversized shaft diameter
- Excessive housing interference fit or undersized housing bore diameter
- Excessive out-of-round condition of shaft or housing

2.3. Improper Bearing Loading

- Skidding rolling elements as a result of insufficient load
- Bearings are excessively preloaded as a result of adjustment
- Out-of-balance condition creating increased loading on bearing
- Linear misalignment of shaft relative to the housing
- Angular misalignment of shaft relative to the housing

2.4. Sealing Conditions

- Housing seals are too tight
- Multiple seals in housing
- Misalignment of housing seals
- Operating speed too high for contact seals in bearing
- Seals not properly lubricated
- Seals oriented in the wrong direction and not allowing grease purge

3. Excessive Noise

3.1. Metal-to-metal contact

- Oil film too thin for operating conditions
- Temperature too high

3.2. Insufficient quantity of lubrication

- Under lubricated bearing
- Leakage from worn or improper seals
- Leakage from incompatibility

3.3. Rolling elements skidding

- Inadequate loading to properly seat rolling elements
- Lubricant too stiff

3.4. Contamination

- Solid particle contamination entering the bearing and denting the rolling surfaces
- Solids left in the housing from manufacturing or previous bearing failures
- Liquid contamination reducing the lubricant viscosity
- Looseness
- Inner ring turning on shaft because of undersized or worn shaft
- Outer ring turning in housing because of oversized or worn housing bore

3.4. Contamination

(continued)

- Locknut is loose on the shaft or tapered sleeve
- Bearing not clamped securely against mating components
- Too much radial/axial internal clearance in bearings

3.5. Surface damage

- Rolling surfaces are dented from impact or shock loading
- Rolling surfaces are false-brinelled from static vibration
- Rolling surfaces are spalled from fatigue
- Rolling surfaces are spalled from surface initiated damage
- Static etching of rolling surface from chemical/liquid contamination
- Particle denting of rolling surfaces from solid contamination
- Fluting of rolling surfaces from electric arcing
- Pitting of rolling surfaces from moisture or electric current
- Wear from ineffective lubrication
- Smearing damage from rolling element skidding

3.6. Excessive Torque to Rotate Shaft

- Preloaded bearing
- Excessive shaft and housing fits
- Excessive out-of-round condition of shaft or housing
- Bearing is pinched in warped housing
- Wrong clearance selected for replacement bearing

3.7. Sealing Drag

- Housing seals are too tight or rubbing against another component
- Multiple seals in housing
- Misalignment of housing seals
- Seals not properly lubricated

3.8. Surface Damage

- Rolling surfaces are spalled from fatigue
- Rolling surfaces are spalled from surface initiated damage
- Fluting of rolling surfaces from electric arcing
- Shaft and/or housing shoulders are out of square
- Shaft shoulder too large and is rubbing against seals/shields

RP 203 Generator Off-Line Electrical Testing

The following recommended practice (RP) is subject to the disclaimer at the front of this manual. It is important that users read the disclaimer before considering adoption of any portion of this recommended practice.

This recommended practice was prepared by a committee of the AWEA Operations and Maintenance (O&M) Committee.

Committee Chair: Kevin Alewine, Shermco Industries
Principal Author: Kevin Alewine, Shermco Industries

Purpose and Scope

The scope of “Generator Off-Line Electrical Testing” provides an introduction to basic electrical tests for the periodic testing and troubleshooting of wind turbine generator electrical circuits. It is not intended to provide specific techniques or recommendations for corrections based on the test results.

Introduction

All generators, regardless of their design, contain at least one wound element where most or all of the energy is generated and made available to the system. They are often complicated windings with many opportunities for weakness, as well as many connections where high resistance is a concern. When most electrical failures occur, a generator specialist is required for correction or repair, but normal operating conditions can often be verified by normal maintenance staff.

Some electrical tests are designed to merely provide a high level of confidence that the machine can be energized safely, but not as predictive tools regarding the longevity of the windings or even their performance under full load. Higher level testing can safely stress the winding insulating at or above normal operation levels and can help develop trends for predictive maintenance.

On-line electrical testing can provide a large amount of useful information, but specialized equipment and training is critical and the parameters for use on wind turbine generators is not yet available as standard testing. Future editions of this standard should address this technology as it develops.

This guide will provide an introduction to several of these tests, but only the insulation resistance testing is recommended for use by non-specialized personnel. Always remember the dangers associated with any electrical testing and follow proper safety procedures. Qualified and accredited companies and technicians should be utilized in most cases. Reference NFPA 70B and NFPA 70E as well as the InterNational Electrical Testing Association (NETA)/ANSI testing protocols.

Generator Off-Line Electrical Testing

1. Common Test Methods

1.1. Insulation Resistance

Insulation resistance testing (sometimes referred to as IR testing, not to be confused with infrared testing) is one of the oldest maintenance procedures developed for the electrical industry and is covered in detail in IEEE Standard 43-2000. This test is fairly simple to perform and can provide information regarding the condition of the electrical insulation in the generator as well as contamination and moisture. This test is recommended before energizing a machine that has been out-of-service or where heating elements have failed to keep the winding temperature above the dew point, which might have resulted in condensation on the windings. It is also useful whenever there is doubt as to the integrity of the windings and before any over voltage testing is performed. An accurate IR test requires a correction factor for the winding temperature to create useful data. The methods and expected resulting data for this test is listed in the standard document. While the test results from IR testing are not normally trended, it is possible to do so to show a gross degradation of the insulation systems. It is, however, very important that the duration of the test, the temperature of the windings and relative humidity be consistent for the trend data to be meaningful.

1.2 Polarization Index

Another test described in IEEE Standard 43-2000 is the polarization index, or P.I., that is useful in some applications to identify contaminated and moist windings. In most modern machines, however, where the insulation resistance is above 5000 megohms the test might not prove meaningful. There has also been a consideration of collecting de-polarization data. Refer to the standards document for additional applications and details.

1.3. Winding Resistance Testing

It is common to use a basic ohmmeter in screening generator winding circuits, but the information gained is not a reliable diagnostic tool because of the many components in the circuit. The use of very low resistance test meters can provide good information, but these tests are very sensitive to temperature fluctuations and trending is difficult.

1.4. Ancillary Component Tests

Testing any auxiliary motors such as those in cooling systems or automated lubrication devices would follow the same basic procedures as the generator itself, but at the appropriate testing range. Other components such as resistance thermal devices (RTD), thermocouples, heater elements, micro switches, etc., are normally checked with an ohmmeter. Consult the manufacturer's literature for specifications.

2. High Voltage Tests

Although these tests are not commonly used in general maintenance procedures, it is useful to have a basic understanding of what tests are available for predictive maintenance trending, troubleshooting, and failure analysis. These tests are generally considered to be non-destructive in nature, but a weakness in the insulation system could and probably should fail during these tests so care should be taken when determining when these tests are advisable. It is recommended that only properly trained generator electrical test technicians should perform these tests.

2.1. High Potential Testing

The high potential test, sometimes referred to as an over potential test, is designed to stress the electrical insulation beyond its normal operating voltages to expose potential failures at a more convenient time. Both AC and DC tests are available, but should only be performed by a generator testing expert. The DC test methods are described in IEEE Standard 95. Trending is possible with this testing, but care should be taken as insulation weaknesses (cracking, contamination, carbon tracking, etc.) can be advanced to failure.

2.2. Step Over-Voltage Test

Using the same equipment as the high potential test, the step over-voltage test stresses the insulation at rising levels of voltage over a set time scale. This is a very useful trending test and is also commonly used in periodic predictive maintenance testing. The same concerns exist as for high potential testing.

2.3. Surge Comparison Test

This type of test is the most common analysis tool for testing turn-to-turn insulation in motors and generators. In this test, a short pulse of high voltage energy at an appropriate stress level is sent through the windings and the results captured on a recording oscilloscope. The patterns of two identical circuits are then compared and the overlaying waves will highlight any differences which represent a potential failure point. A trained test technician can often identify winding failure types by the oscilloscope wave forms. This test is normally used in conjunction with a high potential test. This type of test is described in IEEE Standard 522. Modern automated winding analysis equipment combines many of these tests into a concise report and is very useful for predictive maintenance practices. Again, these high voltage tests should only be performed by a trained generator test technician.

2.4. Partial Discharge Testing

Both periodic and continuous monitoring testing of partial discharge currents and/or corona are common for large, high voltage machines for trending expected useful insulation life. Some techniques do exist for testing low voltage applications, but specialized equipment and training are necessary. It should be considered for long term predictive maintenance programs.

Summary

Good maintenance practice calls for the periodic evaluation of generator electrical conditions and should always be part of a basic maintenance plan. Use of the proper testing protocols can assure safe operation of the generator and can help highlight corrective opportunities before catastrophic failure. True predictive high voltage tests offer useful data for analysis and maintenance scheduling to avoid unplanned outages, but should only be performed by trained technicians.

References

- [1] *Recommended Practice for the Repair of Rotating Electrical Apparatus*, ANSI/EASA Standard AR100-2015, 2015.
- [2] G. C. Stone, I. Culbert, E. A. Boulter, and H. Dhirani, *Electrical Insulation for Rotating Machines: Design, Evaluation, Aging, Testing and Repair*, Hoboken, New Jersey, USA: Wiley, 2004.

References

(continued)

- [3] *Standard Techniques for High Voltage Testing*, IEEE Std. 4-1995 Amendment 1-2001, 2001.
- [4] *Standard Techniques for Testing Insulation Resistance of Rotating Machinery*, IEEE Std. 43-2000, 2000.
- [5] *Recommended Practice for Insulation Testing of AC Electric Machinery (2300 V and Above) with High Direct Voltage*, IEEE Std. 95-2002, 2002.
- [6] *Standard Test Procedure for Polyphase Induction Motors and Generators*, IEEE Std. 112-2004, 2004.
- [7] *Guide for Test Procedures for Synchronous Machines*, IEEE Std. 115-2009, 2009.
- [8] *Guide for Testing Turn Insulation of Form Wound Stator Coils for Alternating Current Electrical Machines*, IEEE Std. 522-2004, 2004.
- [9] *Motors and Generators*, NEMA MG-1-2009 R1-2010, 2010.
- [10] *Recommended Practice for Electrical Equipment Maintenance*, NFPA 70B, 2016.
- [11] *Standard for Electrical Safety in the Workplace*, NFPA 70E, 2018.

RP 204 Converter Maintenance

The following recommended practice (RP) is subject to the disclaimer at the front of this manual. It is important that users read the disclaimer before considering adoption of any portion of this recommended practice.

This recommended practice was prepared by a committee of the AWEA Operations and Maintenance (O&M) Committee.

Committee Chair: Kevin Alewine, Shermco Industries
Principal Author: Aaron Lawson, PSI Repair Services
Contributing Author: Kevin Alewine, Shermco Industries

Safety Notice

The American Wind Energy Association (AWEA) cannot determine or prescribe how industry employers should evaluate their compliance obligation under the Occupational Safety and Health Administration's (OSHA) regulations. Each employer must make its own determinations depending on the condition of the worksite.

AWEA strongly encourages its members to develop their own written program to address worker safety and health procedures, programs, and hazard assessments, as well as provide training for their workers in these areas. Elements to consider when creating a program:

1. Ensure workers utilize appropriate personal protective equipment (PPE) including but not limited to flame resistant (FR) rated clothing, Arc Flash suit and hood, and electrical gloves rated to the electrical hazard present.
2. Follow all electrical safety codes including but not limited to NFPA70E, OSHA, ANSI, etc.
3. Ensure proper Lock Out Tag Out (LOTO) procedures are followed.
4. Allow adequate time for capacitors to discharge before opening converter cabinets. Capacitor discharge times should be provided by the converter OEM. If unknown, wait a MINIMUM of 30 minutes!
5. Ensure there is no dangerous voltage present at the converter by measuring the voltage at the capacitor banks, input and/or output phase terminals.

Purpose and Scope

The scope of “Converter Maintenance” provides an introduction to the operation of converters commonly used in wind turbines. It also addresses basic maintenance and troubleshooting related to the converters. It is not machine specific; OEM documentation should be used where available. Variations to this recommended practice may be necessary in some instances.

Introduction

Converters are used to synchronize the output from a generator to the frequency of the grid. There are various topologies used in wind turbines such as doubly fed induction generators or full power conversion from permanent magnet generators. The converters used are similar and have the same basic components. The maintenance and troubleshooting for these converters are similar and can be applied with a basic knowledge of the converter being used.

Note: The terms converter and inverter are commonly used interchangeably. For the purpose of this document, the term converter will be used. Only qualified and properly trained personnel should be allowed to perform maintenance on converters.

Converter Maintenance Procedures

1. Filter

Inspect the filter for contamination and replace when necessary. The filter should be replaced every year or sooner depending on the dustiness of the environment. Clogged filters will cause cooling fans to work harder, which shortens their lifetime, and will also increase the temperature of the converter, which will lead to a shorter converter lifetime.

2. Electrical Connections

Inspect terminals for loose connections, corrosion, and damage from high temperature. Inspect wiring for cracked insulation, abrasions, and discoloration. Inspect the condition of all wire crimps. Repair or replace any cables or terminals that show damage. Terminals on the phase connections as well as the DC link connections should be inspected. Ensure that no insulation is trapped under terminals. Verify all connections are tightened using the specified torque ratings. Improperly tightened electrical connections will heat up and eventually fail.

3. Fiber Optic Cables, If Equipped

When fiber optic cables are removed, care should be taken to ensure dust and debris are not allowed to come in contact with the cable or transceiver ports. Use clean and dry compressed air to blow off dust from the cables, connectors, and transceiver ports. Isopropyl alcohol and lens paper can be used to clean off cables and connectors. Never use dry lens paper as it is extremely abrasive when dry. Never insert any foreign object into a transceiver port. Install covers or plugs to prevent dust from contaminating cleaned fiber optics. Commercial optical cable cleaning kits are also available; follow their instructions for proper use.

4. Heat Sink

Inspect heat sink for dirt or debris. Heat sink fins will pick up dust and dirt from the cooling air. Dirty or clogged heat sinks will not allow heat to be efficiently removed from power electronic components and cause a shortened lifetime. Heat sinks should be inspected and cleaned at least annually but more often if the environment is excessively dusty. Cleaning can be accomplished by blowing clean and dry compressed air through the heat sink and capturing dust using a vacuum cleaner at the outlet. Care must be taken to prevent dust from entering adjoining equipment. Oil or grease contamination must also be removed from heat sink surfaces and fins.

5. Fans

Test for proper operation of the cooling fans. If the heat sink temperature gradually rises over time, this may be an indication of a failing fan. A handheld anemometer can be used to verify the proper airspeed. If the airspeed is low, the fan should be repaired or replaced. Increased noise or vibration from a fan is an indication of bearing failure and the fan should be repaired or replaced before complete failure. Clean the fan blades and guard of any accumulated dust and debris or other obstructions.

6. Liquid Cooling System, If Equipped

Inspect the heat exchanger for dust and debris and clean if necessary. The coolant pump should be tested for proper operation. Many pumps will have a pressure gauge that should indicate the pump is operating correctly. Excessive noise from the pump may be an indicator of a failing pump or motor. The entire coolant system should be inspected for leaks and repaired as necessary.

6. Liquid Cooling System, If Equipped

(continued)

Coolant should be tested for proper refractive index and adjusted as necessary. A refractometer should be used with the proper scale; an automotive hydrometer is not acceptable for converter coolant testing. Distilled water should be used with the specified antifreeze; potable water should never be used due to its mineral and chemical content variation. Coolant level and refractive index should be tested every 6 months unless otherwise specified by the manufacturer. Coolant should be completely replaced (to renew the corrosion inhibitors) every 5 years unless otherwise specified by the manufacturer.

7. Seals

Inspect enclosure and door seals for condition. Damage to seals will allow dirt and contamination to enter the enclosure. Proper airflow can also be affected by damaged seals. Replace if damaged. Cable glands should also be inspected for proper sealing or damage.

8. Enclosure

Inspect all enclosures and remove any loose hardware, insects, or any other foreign objects. Vacuum any accumulated dirt or debris that may be present inside the enclosure.

9. Converter Control Unit

Depending on the type of converter control unit, a memory backup battery may be used. This battery should be replaced as recommended by the manufacturer, or at least every 5 years. Care should be taken when replacing this battery to prevent electrostatic discharge (ESD) damage to the electronics. Proper replacement procedures should be followed to prevent memory data loss.

10. Thermographic Inspection

Thermal cameras can be used to inspect converter equipment when under load for abnormal heating of components and electrical terminals. Proper training is required when using thermal cameras. Consulting with a certified and experienced thermographer is recommended. Proper PPE is required when accessing a converter cabinet under load as there is an extreme danger of arc flash and hazardous voltages are present.

10. Thermographic Inspection

(continued)

Baseline thermal images may be required to ensure abnormal conditions are properly identified. Areas to inspect include electrical terminals, insulated gate bipolar transistors (IGBTs), capacitors, control circuit boards, and heat sinks/cooling systems. Loose terminals will show up hotter than properly torqued terminals. Failing IGBTs, capacitors, or components on circuit boards may appear hotter than other components in the system. Improperly functioning heat sinks or coolant lines may appear cooler than when they are properly operating.

11. DC Link Capacitors

Two main types of capacitors are used in converters: aluminum electrolytic and film capacitors. Aluminum electrolytic capacitors have a shorter lifetime than film capacitors. Many newer converters use film capacitors for this reason. The lifetimes of both types of capacitors are dependent on the ambient temperature, operating time, and loading of the converter. Testing DC link capacitors are difficult without the proper equipment. Standard equivalent series resistance (ESR) meters are not able to test high capacitance and voltage of DC link capacitors.

Visually inspect capacitors for bulges, dents, burns, or other abnormal marking and replace any that have damage. Large aluminum electrolytic capacitors commonly have a vent plug that will pop out in the case of an over voltage or over temperature event. Replace any capacitors that have a missing vent plug. Clean DC link capacitors and bus bars of any dust and debris as this can cause arcing across their terminals.

12. Insulated Gate Bipolar Transistors (IGBTs)

Inspect IGBTs for dust and debris. Clean any contamination on or near their terminals as this can cause arcing. A digital multimeter can be used to check IGBTs for shorts across their collector and emitter terminals.

Troubleshooting

Most wind turbine control systems deliver codes when a fault occurs. These codes give important information that can aid the troubleshooting process.

Troubleshooting

(continued)

1. Possible causes of common failures codes:

1.1. Over Temperature:

- Defective temperature sensor/switch or thermostat
- Dirty or clogged heat sink
- Dirty or clogged filters
- Failure of cooling fan
- Low coolant level
- Kinked coolant hoses
- Exceeding converters ambient operating temperature

1.2. Over Current:

- Phase-to-phase short
- Phase-to-ground short
- Shorted IGBT
- Faulty current transformer/transducer
- Faulty converter control unit
- Shorted generator
- Shorted cabling
- Faulty crowbar circuit, if equipped

1.3. Switching Frequency:

- Faulty rotor converter
- Loose or damaged rotor cables
- Faulty slip ring brushes

1.4. DC Overvoltage:

- Static or transient overvoltage on grid
- Failed converter
- Faulty line side converter contactor

1.5. DC Undervoltage:

- Open grid supply fuse
- Open DC fuse
- Faulty converter

RP 207 Wind Turbine Generator and Converter Types

The following recommended practice (RP) is subject to the disclaimer at the front of this manual. It is important that users read the disclaimer before considering adoption of any portion of this recommended practice.

This recommended practice was prepared by a committee of the AWEA Operations and Maintenance (O&M) Committee.

Committee Chair: Kevin Alewine, Shermco Industries
Principal Author: Kevin Alewine, Shermco Industries
Contributing Author: Aaron Lawson, PSI Repair Services

Purpose and Scope

The scope of “Wind Turbine Generator and Converter Types” provides an introduction for managers and technicians new to wind energy to some of the most common generator and converter technologies utilized in wind turbines. These are not manufacturer specific and several variations are found, but these types make up the majority of the North American fleet. It is hoped that this can provide some common terms and nomenclature for use when addressing generic issues and solutions as well as design-specific concerns.

Introduction

As the wind energy industry continues to grow and the reliability of turbine fleets becomes more critical, manufacturers have focused on generator designs that have proven successful in this severe application. While traditional generator designs have been used, there are several technologies utilized that are less common in utility or industrial applications. A typical engine driven generator, as an example, is designed using a salient pole generator where the frequency generated is dependent on the rotating speed and drive torque is managed to match the load. Constant speed is a real problem in wind generation, so more innovative solutions are required. The variability inherent with the wind has led to the development of complex control systems and high power electronics. These devices work in conjunction with the generator to maximize the power output and the useful wind speed range. They also stabilize the output frequency and power factor regardless of mechanical input.

Wind Turbine Overview

The two basic types of drivetrains used in current designs are the traditional rotor/gearbox/generator style or the direct drive design where the rotor is directly connected to a relatively large diameter generator. In the traditional design, the gearbox increases the relatively low input speed, typically 17-20 RPM, to a high-speed output shaft connected to a 4 or 6 pole generator. Newer designs developed for large off-shore machines will probably use a simpler, more robust gearbox with a medium speed output to an 8 pole generator.

The early versions of the direct drive turbines used generators with many pole pieces, often nearly 100, much like a hydro turbine. Although some of these models are still in production, other configurations are more popular as output ranges increase. Newer direct drive turbines typically utilize permanent magnets rather than individual pole pieces.

With rare exception, wind turbines generate electricity at 690VAC and utilize internal or external step-up transformers to match project distribution requirements. This low voltage, high amperage configuration has proven to be reliable and cost-effective in nearly all wind turbines regardless of manufacturer. One reason for this specific voltage level has been the limits to the maximum operating voltage of power electronic devices used in wind converters. Insulated gate bipolar transistors (IGBTs) have been limited to maximum voltages of 1200V-1700V in the past. Currently, device manufacturers have IGBTs with maximum voltage ratings of 3.3kV-6.5kV^[1]. These higher voltage IGBTs have the downside of being much more expensive than the more common IGBTs in the 1200V-1700V range.

In addition to these higher voltage IGBTs, converter manufacturers are developing multilevel converters which further expand the possible output voltage for wind generator applications. For example, a medium-voltage converter can be designed with modern 6.5kV IGBTs in a seven-level topology with maximum voltages up to 11kV^[2]. One downside to multilevel converters is that the high number of IGBTs requires a very complex control system.

Fully Converted Generator Design Types

Most modern wind generators utilize one of three basic induction generator types: asynchronous induction (squirrel cage), permanent magnet rotor, and doubly-fed induction (DFIG). In this overview, these types of generators are briefly described, the benefits and shortcomings of each are explained, and the types of electronic controls necessary for excitation, frequency conversion, and synchronization with the grid are covered.

Traditional Synchronous Generators

The traditional salient-pole generators common to general industrial and commercial applications have been used in just a few designs of wind turbines. The output compared to their weight and complexity has not proven popular. Their need to run at a constant speed to synchronize with the grid also complicates their use. One of the few successful designs required the use of not only a gear box but also a fluid drive to maintain generating frequency, making the weight, cost, and maintenance complexity of the entire drivetrain generally undesirable.

Asynchronous Induction Generators

This design was one of the earliest used in wind generation where all of the output was converted to DC and used to charge batteries, similar to automotive applications. As the size of turbines grew dramatically and the cost of large power converter components fell, these machines have been scaled to operate in the 2-3MW range. In this design, power is supplied to the stator windings to induce current in the already rotating squirrel-cage rotor. This excitation current supplies the rotating magnetic field that generates AC current from those same windings. This is a very simple generator, but not-so-simple power conversion equipment. Effectively, an AC/DC-DC/AC convertor is used on the output current with the frequency matched to the grid by high power semiconductor inverters that maintain the synchronization necessary.

Most of the generators used in this application generate 690VAC over a wide speed and current range. The converter is the key to grid stabilization, power factor, and reliability. The benefit of this design is that up-tower maintenance is simplified, but the risk is that it can be very expensive to replace failed electronic components, even if they are easier to access.

Permanent Magnet Generators

These generator designs were once thought to be the solution for many of the maintenance costs, and they are, in fact, proving to be very reliable machines in general. However, the costs associated with manufacturing these units can negatively impact the financial strategy of developers, so they remain less popular in many areas. In these designs, the excitation is supplied by the magnets on the rotating element. Like the standard induction generators, the AC output is fully converted by the electronics, which are simpler in design than either the induction generators or the doubly-fed induction generators discussed below.

Permanent Magnet Generators

(continued)

Maintenance is minimal on these machines and they may continue to be popular where long term operating costs are taken into consideration when planning the wind project, as they are in Asia and Europe. Most of the current designs utilizing permanent magnet generators are direct drive machines where an outer ring housing the magnets rotates around a wound core, which greatly improves the reliability of the windings. The ring is connected directly to the rotor and hub assembly and supported, typically, on a single, very large main bearing.

Full-Scale Converters (FSC)

Synchronous, asynchronous, and permanent magnet generators can all be used with full-scale converters (FSC). There are two major types of FSCs used today: Rectifier Full-Scale Converters and Back-to-Back Full-Scale Converters.

Rectifier Full-Scale Converters (FSC)

Rectifier FSCs use simple rectifiers on the generator stator output which reduces the number of IGBT modules and corresponding control units required. This leads to a reasonably priced and efficient converter. Some disadvantages are increased losses due to the need for induction current and harmonics caused by the uncontrolled rectifier.

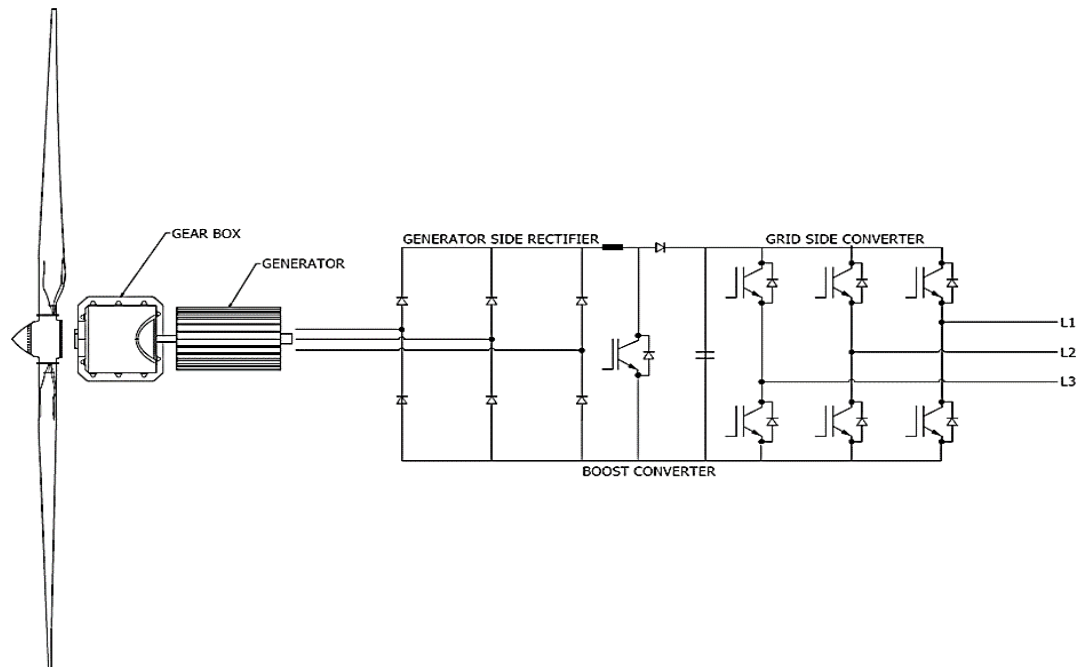

Figure A: Rectifier Full-Scale Convertor

Back-to-Back Full-Scale Converters (FSCs)

Back-to-Back FSCs are becoming the most widespread topology used in the wind turbine field. These consist of two identical converters connected back-to-back to the grid side and generator side. This design is able to achieve minimum machine losses and the maximum range of control. The generator can be utilized efficiently over a wide range of speeds and the full reactive power can be made available during low wind conditions^[3]. A major downside of this type of converter is the high cost due to the requirement of two identical converters using expensive power electronics.

Power can be produced at a lower cost if a wind turbine can operate within a wider range of wind speeds. This increases the profitability for the wind farm. Both types of full-scale converters allow a wide range of wind speed using modern generators and convert the full output power.

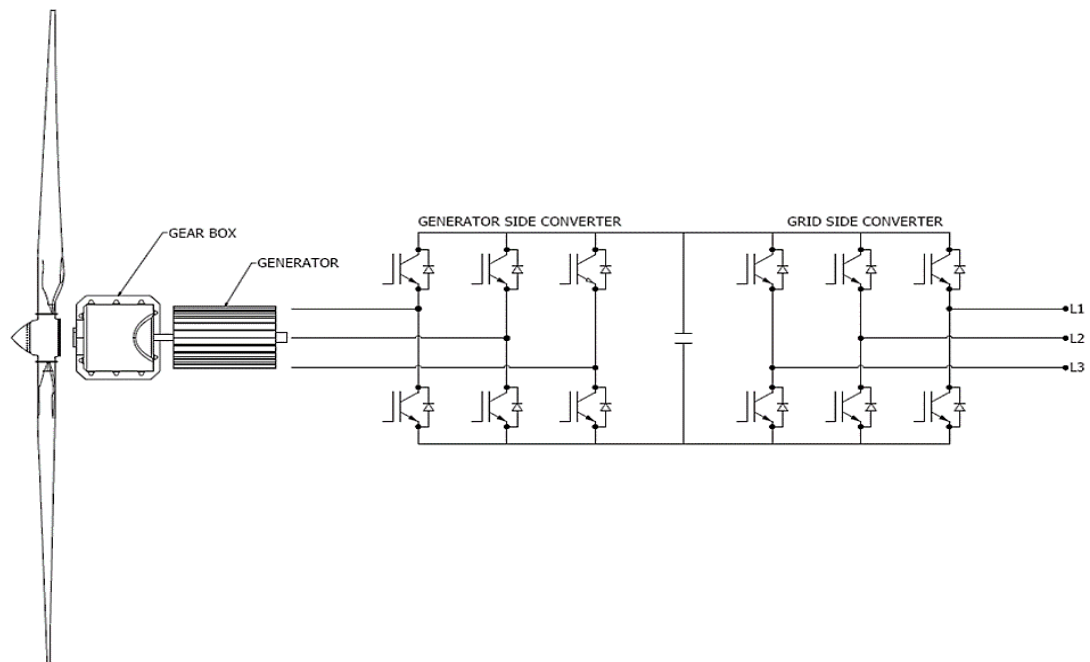

Figure B: Back-to-Back Full-Scale Converter

Doubly-Fed Induction Generators (DFIG)

This type of generator is relatively rare outside of the wind industry, but they have been well accepted by many turbine OEMs as their standard design. With a fairly high power output to weight ratio, these offer a good value for the initial cost of a wind project. This design utilizes a wound, three-phase rotor with excitation power provided through a slip ring assembly. Unlike a traditional generator, where the rotor provides the rotating magnetic field and all power is generated by the stator, if these machines are operated above the synchronous speed, then a positive current flow also comes from the rotor. This allows for a much smaller machine.

Converters for doubly-fed induction generators control the slip of the generator. They supply excitation current to the rotor when the generator is below synchronous speed. When the generator is above synchronous speed, the converter will take excess current from the rotor and supply it to the grid. This increases the amount of power the generator can create at high speeds and also increases the wind speed range capable of useful power generation.

An advantage of DFIG designs is the majority of the power generated is supplied directly to the grid. The converter used is only required to convert 30% of the power from the generator. The IGBTs and other power electronic components necessary are substantially smaller and less expensive than those used in full-scale converters. These converters maximize the tradeoffs between cost and range of useful wind speed when compared with full-scale converters. One of the main disadvantages, discussed above, is the requirement for slip rings which require regular maintenance. A second disadvantage is the IGBTs must be able to cope with high peaks in current and voltage during grid faults.

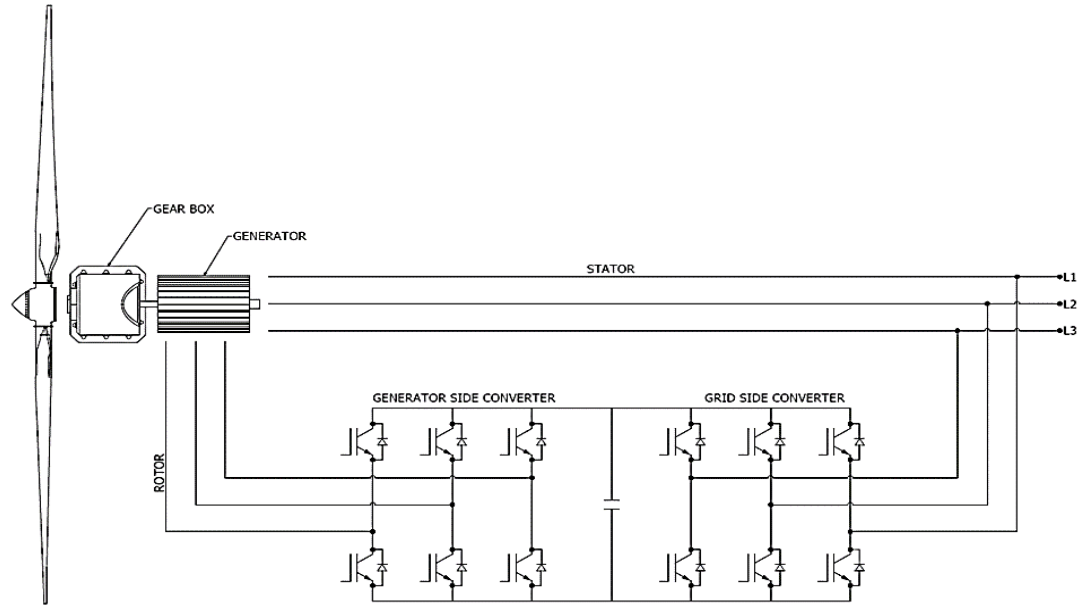

Figure C: Doubly-Fed Induction Generator

More About Convertors

In all applications, regardless of generator type, the basic construction and function of the converter are the same. They consist of IGBTs to switch the power, DC link capacitors to store energy and decouple back-to-back converters, snubber capacitors to lessen voltage spikes during switching, a bus structure with low inductance to connect the power electronics, drive electronics to provide IGBTs with the proper turn-on and turn-off signals, and control electronics to control the converter frequency and switching signals. A water or air cooled heat sink is also used to remove excess heat generated by the IGBTs during switching. The converter switches at 1200-4500Hz in a pulse width modulated (PWM) waveform. PWM is a modulation technique used by converters to generate a sine wave from a DC voltage. The converter creates a square wave with a varied duty cycle. Duty cycle is the on-time over the period of the square wave. The overall average of the PWM waveform is equivalent to an alternating current sine wave. The output is then filtered using a line reactor and power factor correction (PFC) capacitors prior to being fed into the pad mount transformer and ultimately to the grid.

References

- [1] Infineon.com. "IGBT Modules," 2017. [Online]. Available: www.infineon.com/cms/en/product/power/igbt/igbt-module/channel.html?channel=ff80808112ab681d0112ab69e66f0362.
- [2] M. R. Islam, Y. Guo, and J. Zhu, "Power converters for wind turbines: Current and future development", in *Materials and Processes for Energy: Communicating Current Research and Technological Developments*, Bardoja, Spain, Formatex: 2013, pp. 559-571.
- [3] Semikron.com. "Application Examples," 2017. [Online]. Available: www.semikron.com/applications/wind-energy/application-examples.html.

All images courtesy of PSI Repair Services.

RP 208 Shaft Current Management

The following recommended practice (RP) is subject to the disclaimer at the front of this manual. It is important that users read the disclaimer before considering adoption of any portion of this recommended practice.

This recommended practice was prepared by a committee of the AWEA Operations and Maintenance (O&M) Committee.

Committee Chair: Kevin Alewine, Shermco Industries
Principal Author: Rob Hefner, Schunk Graphite
Contributing Author: Roland Roberge, Morgan AM&T
Reviewing Committee: Benoit White, Mersen

Purpose and Scope

The scope of “Shaft Current Management” addresses the common maintenance issues related to the grounding systems for generator and drive train shafts in various wind turbine designs. It is not machine specific and some adaptation may be required based on specific designs.

Introduction

A wind turbine generator shaft is usually protected by a grounding system to prevent currents from passing onto the generator and/or drive train bearings. The use of carbon brushes contacting the shaft rotating area and tied into the unit’s grounding is the most popular way of managing unwanted shaft currents. These brushes are wear items and should be included in any regularly scheduled maintenance inspection or process. The normal recommendation is to inspect and clean the brush and assembly at least bi-annually, but longer maintenance cycles may be possible with improved materials and designs. Brush life is affected by carbon grade, shaft speed, ambient temperature and humidity, and other operating environmental conditions. During maintenance, a careful visual inspection should be performed and any abnormal conditions should be documented, preferably including photographs.

Understanding the Need for Shaft Grounding

Shaft voltages can be caused by:

- Asymmetry in the magnetic circuit of rotating electrical machines
- Build-up of static charges within the shaft
- Capacitative coupling of voltages into static exciting systems

Understanding the Need for Shaft Grounding

(continued)

If current passes via the bearings of an electrical machine, high current densities may occur on the small contact points within the bearing, which can result in a local melting of the metal surfaces. The consequence is the formation of small craters and serrations. This typically increases the internal friction of the bearing and worsens over time causing increased temperature, contaminated lubrication, and ultimately bearing failure.

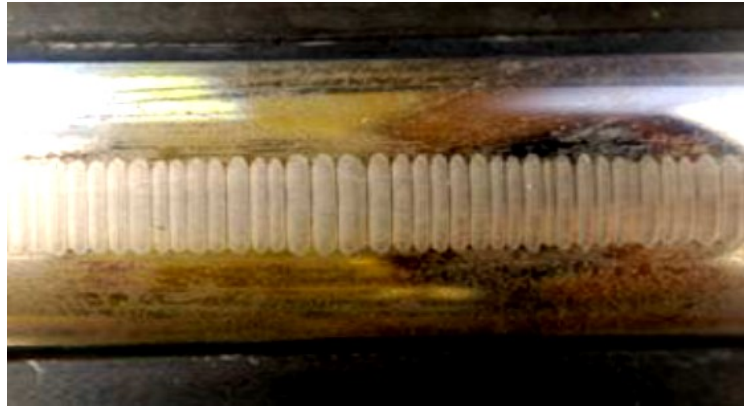

Figure A: Ripple formation on bearing race caused by voltage passing through bearing (fluting)

Electrical insulation of the bearings is a common practice but is not always sufficient. Shaft grounding with carbon brushes helps to protect components by grounding out the majority of the voltage/current before making contact. This grounding is typically achieved by two brushes being mounted in a 90° angle on the shaft as seen in the Figures B and C below. Varying grades may be recommended based on the operating conditions and the turbine manufacturer, or a trusted carbon brush manufacturer can help with choosing the proper grade for the conditions.

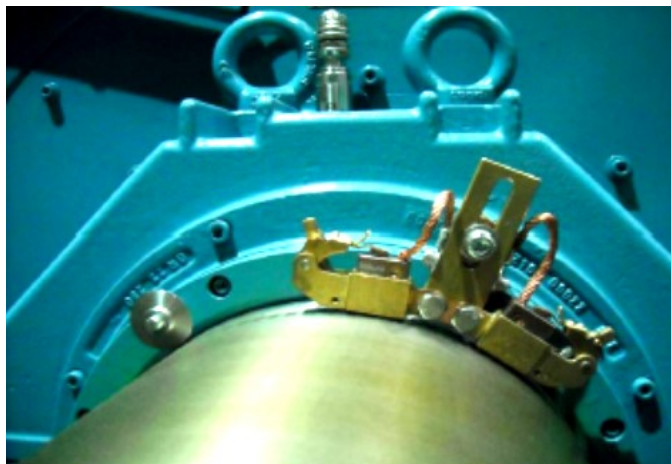

Figure B: Example of Main Shaft Grounding

Understanding the Need for Shaft Grounding (continued)

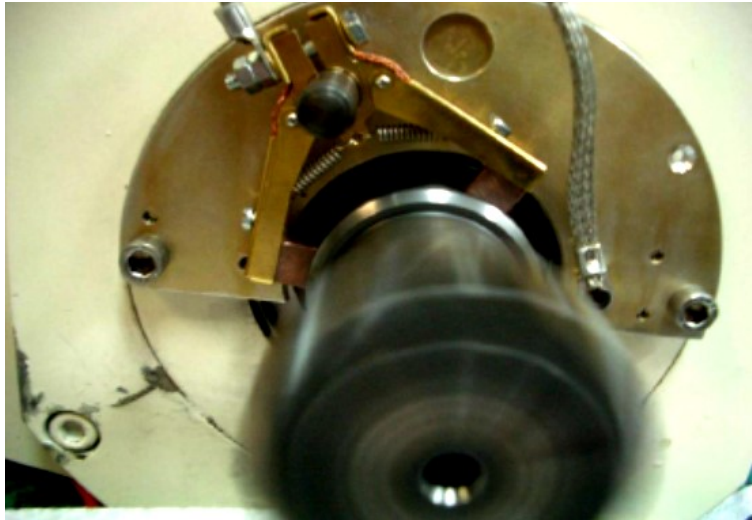

Figure C: Example of Generator Shaft Grounding

Shaft Grounding Maintenance Procedures

1. Inspecting The Assembly

Remove the shaft cover if one exists. View the general condition of the assembly. Note any build-up of residue, leaking gaskets, broken or missing components, etc. It is always good to document the “as found” condition of the brush and assembly with an image.

1.1. Brushes

1.1.1. Removal

To remove the brush from most designs, pull back the spring loaded holder arm and loosen any connections to the holder assembly. Other styles of tension devices may be in use. Consult the manufacturer’s specifications for a specific generator design. Pull the brush out of its holder by its cables without disconnecting it. Note the orientation of the brush to the holder to ensure the brush will properly be reinstalled if it is not to be replaced.

1.1.2. Brush Body

Inspect the brush for minimum length requirement, any unusual wear-marks, and free movement of the brush in the holder noting any restriction that maybe a sign of material swelling.

NOTE: This should also be a regular test for lightning protection brushes.

Inspect for chipping or cracking. Assure that the terminals are secure and that shunts, micro switch tabs, etc., and rivet connection, if applicable, are in good working order and properly mounted and connected.

1.1.3. Shunt Wires

Discolored shunt wires can indicate overheating or extreme current discharges. It is recommended to replace the complete brush set, because single brushes can already be damaged. If the shunts are damaged or frayed by vibration or mechanical problems, they should also be replaced and the condition corrected. Note any abnormal wear indicators. Verify terminal connections are secure on all brushes. Additionally, shunt wires should still be pliable when moving. If the shunt wires are rigid, they are susceptible to damage causing reduction in conductivity and the brushes should be changed.

1.1.4. Brush Surface

Rough brush face surfaces may be caused by brush sparking from electrical or mechanical problems.

Rule of thumb: If one of the brushes has to be replaced and the set is worn more than 25%, all the brushes should be replaced. If all brushes are to be replaced, disconnect them and remove them from the assembly. Loosen the terminal bolts until the brush terminal can be slid out from under it. If possible, do not fully remove the bolt to avoid dropping it and other hardware into the assembly.

1.2. Brush Holder

1.2.1. Holder Box

Inspect entire holder for any indications of arching or burning damage. Verify that all hardware and electrical connections are secure. Note any abnormal wear indicators.

1.2.2. Springs

Inspect tension devices for any indications of arching, burning or discoloration. The spring force should be checked every year with an appropriate spring scale device and springs should be replaced every 3 to 5 years depending on type of application. Springs with a deviation of more than 10% from the set value should be replaced.

1.2.3. Holder Distance

For a safe guidance of the brushes in the brush holder it is normally suggested that the distance between holder and shaft surface is no more than 3 mm (0.125”).

1.3. Counter Surface

Inspect the shaft surface where the brush makes contact. There should be a film (or patina) of on the shaft. **LEAVE THE FILM AS IS!** This helps with the wear and connectivity of the brush to shaft surface. If oil or grease comes into contact with the counter surface, an insulating film can be formed which hampers the current transfer. Increased brush wear could be the consequence. The brushes are porous and, in case of oil contamination, all brushes should be replaced after the shaft surface is cleaned.

2. Cleaning and Reassembly

2.1. Cleaning the Shaft Surface

Typically the generator shaft is a clean area of a generator, but carbon dust may build up over time in this area. For these cleaning procedures, it is suggested that appropriate personal protection devices be worn, including a dust mask.

Use a small vacuum, preferably with a HEPA type filtration system, and a synthetic brush to remove all accumulated dust and other contaminants from the shaft, the brush holder assemblies, and any areas where the dust may have collected below the shaft. Contact cleaner or other solvents should not be used directly on the brushes or the shaft surface. If it is necessary to use a solvent, spray the solvent on a disposable towel or cloth and use the cloth to wipe the solvent on the unclean area. Do not use solvents on carbon brushes because they could affect the carbon material. The surface film (or patina) should not be cleaned with a solvent. Always clean from the top down to avoid re-contaminating components.

2.2. Installing Brushes

To install new brushes or to reinstall brushes after inspection, insert the brush into the holder ensuring the proper orientation then affix the brush back to its operating position. Connect new brushes and check that the connection is tight and the terminal is located correctly under the spring washer. As a final check to assure that the brush is free to move up and down in the brush holder and that the spring is correctly fitted, pull on the brush leads and lift the brush approximately 12 mm (0.5") and then lower it back onto the shaft a few times. Assure that the brushes are oriented 90° to the shaft and that as much surface as possible is in contact with the shaft surface to avoid premature wear.

2.3. Seating New Brushes

In the event new brushes are manufactured with a bottom radius, seating may be needed to ensure the proper electrical continuity.

Garnet paper or any non-metal bearing abrasive paper is recommended, and cloth backed abrasives are often easier to use in many circumstances. The abrasive size should be 80 to 120 grit. Fine sandpaper, such as 400 grit, will easily fill with carbon making the sanding process more difficult. It is important not to leave abrasive particles under the brushes when completed as these could damage the counter surface.

Seat one brush at a time while all the other brushes are still connected but out of their holders.

Lift the brush by its shunts and slide a strip of the abrasive cloth under it with the abrasive side of the paper facing the brush. Lower the brush down onto the abrasive cloth and place the spring in its normal engaged position. The spring should apply the pressure to the brush. Slide the garnet paper back and forth under the brush in line with the brush path. After several of passes back and forth, remove the brush from its holder and check the face of the brush. The seating is complete when at least 80% of the brush face is abraded. Vacuum out all of the accumulated carbon dust and sanding debris and reinstall the brush

Once properly assembled, assure that all bolts are tightened and the brushes are properly connected.

2.3. Seating New Brushes

(continued)

As a final check that the brush is free to move up and down in the brush holder and that the spring is correctly fitted, pull on the brush leads and lift the brush approximately 12 mm (0.500") then lower it back onto the shaft a few times.

Also, make sure that all tools and cleaning materials are removed from the area and that any cover gaskets are functioning properly before replacing the cover, if applicable.

Summary

This recommended practice is designed to identify basic procedures and techniques for maintaining the collector ring assemblies in double fed induction generators. Careful cleaning, maintenance, and proper brush replacement, when required, will assure long, trouble free service life for these critical components.

Chapter 3 Rotor and Blades



Operations and Maintenance
Recommended Practices

version 2013

RP 301 Wind Turbine Blades

The following recommended practice (RP) is subject to the disclaimer at the front of this manual. It is important that users read the disclaimer before considering adoption of any portion of this recommended practice.

This recommended practice was prepared by a committee of the AWEA Operations and Maintenance (O&M) Committee.

Committee Chairs:

Jim Sadlo, 3M

Gary Kanaby, Wind Energy Services

Principal Authors:

Jim Sadlo, 3M

Robert Schmidt, M4 Wind Services

Purpose and Scope

The scope of “Wind Turbine Blades” addresses proper purchase, transportation, maintenance, repairs, and balancing of wind turbine blades.

Introduction

The purpose of this document is to provide turbine manufacturers, owner/operators, and independent service providers in the wind energy industry with a description of the best maintenance, inspection, and repair practices for the blades and nose cones employed on wind turbine rotors. These best practices are to serve as a guideline with the understanding that economics will drive the actual implementation decision at each individual wind farm.

Wind Turbine Blades

1. Inspections

1.1. Areas of inspection

Blades need to be checked in detail and their condition is to be documented. Irregularities and damages are to be detected and a recommended repair date specified. The blades need to be checked in detail by a reputable technical expert. Scope and type of inspection are taken from the following table. (See *Table A*)

Table A. Areas of Inspection.

| Component to be Checked | Type of Inspection and Check-points | Minimum Inspection Frequency Every 2 Years* |
|---|---|--|
| Blade Body | visual evidence of cracks, air pockets, delamination, drainage, protective film and erosion of the leading edge, lightning protection system, spark gap documentation of blade, pitch angle documentation of blade moment balance | <i>*Selected inspections may be needed after environmental incident events. Lightning storms, severe winds, hail, etc.</i> |
| Flow Elements | turbo rills, vortex generators, micro swirl prong bands, gurney flaps | |
| Visible Profile Accuracy | characteristics of the trailing edge, light reflection | |
| Blade Inner | If technically possible, the blade should be checked from the inside. It is important that the area is stable enough. delamination, bars: cracks, finish of web adhesion | |
| Blade Sealing To Hub | oil in the blade, lightning protection system within the blade | |
| Extender | corrosion, bolts, weld seams | |
| Wind Turbines Tip Stall Mechanism | play, grime, adjustment, crack, guide tube, damping plate, index pins, bolts and cross bolts, function | |
| Wind Turbines Blade Pitch Adjusting Device | bearings, grease condition, play in mechanism, leaks, gear tooth contact pattern, connecting rod, oil in the blade | |
| Wind Turbines Blade Pitch Adjusting Cylinder | leaks, mechanical stops, blade adjustment locking device | |
| Wind Turbines Pitch Return Element | function, tighten the accumulators | |
| Wind Turbines Pitch Electrical Cabinet | tighten within hub | |
| Bolts, barrel nuts, bushings | Check torque, wear, corrosion | |

1.2. Pre-Purchase Audit

In addition to the inspections listed above, documentation on the blade set should include the blade weights, the blade centers of gravity, manufacturing date, and repairs made to the blade before delivery, which should include rework to bond lines, lamination defects (wrinkles), dry spots, and leading edge reshaping. This information should be kept with the rotor set's O&M record for life of rotor.

1.3. Delivery/Commissioning Inspections

Assure all rotor sets are assembled as specified. Assure all surface defects since leaving OEM are resolved properly. Major pre-purchase repairs should require confirmation of balanced blade set. Confirm all rotor sets hung in proper/consistent order, e.g. A-B-C, etc.

1.4. Environmental Incident Inspection

Immediately following an environmental incident a ground based visual inspection for obvious blade damage should be conducted. Based on those observations, additional inspections from the list above should be conducted.

1.5. On-going Inspections

Part of a consistent O&M recommended practice is to have a documented on-going inspection plan where all turbines are inspected on a regular basis. Extra inspections on problematic blades are highly recommended, as are higher inspection rates on previously repaired blades.

1.6. Pre-End of Warranty Inspection

The key to the end-of-warranty inspection is to plan well ahead of the end-of-warranty in order to better plan out this inspection. Planning ahead is important because a single inspection may require a follow up inspection prior to bringing any warranty issue to the OEM before the warranty period is completed.

2. Transportation and Storage

2.1. Transportation

All blades need to be shipped in compliance with the OEM transportation specification. Recommended practice would be to have this specification on-site prior to the shipping of the blades to assure that all specifications are met, and in case any conflicting issues arise that deviate from this specification. Specific things to inspect are the bracing and support of the blades. Inspect for proper cushioning and support on the leading edge, proper side support on the shell body so as not to induce longitudinal cracking, proper cinching of cargo straps so as not to damage trailing edge, and proper bracing on the blade to prevent adverse flexing during transportation.

2.2. Storage

Storage of blades needs to be different for the intended length of storage. Short periods of storage, such as staging for installation, can be varied as long as the blade is not exposed to undue mechanical strain or an environment that would compromise the exterior structure of the blade. Long term storage needs to address the following:

- Protection from UV light
- Root bolts sealed from moisture
- Blade protected from rain, dust, and foreign objects, including small animals and insects, from entering the interior of the blade
- Blade properly secured to the ground to prevent damage in high winds
- Blade properly supported to mitigate any mechanical stresses on the structure of the blade (leading edge, trailing edge, shell wall)

3. Maintenance

Preventive maintenance schedules have repeatedly shown to be more cost effective than responding to issues as they arise. There are many formats for maintenance schedules, but the key is to incorporate one that will be followed consistently by the site team. This may include having a third party conduct all PMs and repairs on a long term contractual agreement.

There are many visual and auditory inspections that can be used as part of the preventative maintenance plan which require little effort and do not require interrupting the generation of power. High speed digital photography for identifying lightning strikes, trailing edge cracks, and foreign object strikes can be conducted from the ground. Changes in the sound of the rotor set spinning can also be

3. Maintenance

(continued)

Typical preventative maintenance plans will address the areas mentioned in Table A. Additionally, as the rotors age, a representative set of rotors should be physically inspected for defects, wear, and damage by some form of blade access. The set of rotors physically inspected should change each year, so as to have each rotor set physically inspected on a regular basis. This varies from farm to farm, but a 2 to 10 year rotation is common. Items identified with these inspections could alter the rate of inspection and should be used to plan repairs so as to minimize costs, e.g. bunching repairs to lower cost per turbine repaired.

The maintenance data collected for each blade and rotor set needs to be retained with the rotor set for the life of the farm and it needs to be reviewed on a regular basis for potential predictions on power loss, potential failures, etc.

Blades and rotor sets that continuously have more issues, should have their PM scheduled more frequently to minimize reactive maintenance and to aid in understanding trends for the rotor set.

4. Repair

All repairs whether under warranty or past the warranty period should be conducted with OEM approved materials. The primary key to all repairs is to return the blade to the same physical strength, shape, and weight as when it was commissioned. Usually the exact same manufacturing process cannot be used to facilitate the repair, thus the repair may be thicker or heavier in the repair location to obtain the same structural strength as in the original location or it will be lighter or not as structurally strong to return the location to the same surface profile. Depending on the location and its critical performance function, the repair team will need to decide how best to complete the repair.

4.1. Safety

Repairing and maintaining rotor sets creates additional safety concerns beyond the concerns already presented on every wind farm. Safety needs to be foremost in all maintenance and repair programs. The information below is meant to be adjunct to an existing site safety program. As noted above in the SAFETY NOTICE, this information is meant for awareness and all implementers of the processes are responsible for determining appropriate safety, security, environmental, and health practices or regulatory requirements.

4.1. Safety (continued)

4.1.1. Fall Protection and Rescue

All personnel that access the nacelle area of a wind turbine should be trained and certified to safely climb the tower and to perform self and others rescue. Personnel should be trained in the dangers of working at a height, how to use and maintain lanyards, fall arrest harnesses, and positioning equipment and other climbing gear. In addition, personnel should be trained in the correct methods of dealing with emergencies including suspension trauma and rescue.

Testing and Certification should be obtained from a recognized third party organization such as ENSA, ANSI, or NIOSH standards, which should include:

- Safety awareness
- Equipment fitting
- Care and inspection of equipment
- Risk assessment
- Restraint
- Fall arrest
- Work positioning
- Rescue
- Anchor selection
- Evacuation

4.1.2. Aerial Platform Competent User, Safe Access and Rescue

External servicing of the turbine's blades can be performed up-tower utilizing suspended platforms or crane man-baskets. It is critical that service personnel be trained and certified in the operation of vertical lifeline systems, rigging, safe operation of the platform, and self-rescue and assisted rescue using ANSI approved automatic control descent devices.

4.1.2. Aerial Platform Competent User, Safe Access and Rescue

(continued)

Specific areas to be trained and certified include:

- Safe use of vertical lifelines
- Establishing a safe work area
- Platform and rigging equipment inspection
- Rigging
- Pre-lift testing
- Platform components and assemblies
- Safe operation of the platform
- Tag line operation
- Assisted rescue
- Self rescue
- Coworker rescue
- Sling angles
- Sling ratings
- Anchor point requirements
- OSHA requirements

4.1.3. Rope Access

In addition to Fall Protection training, service personnel should be specifically trained and certified to SPRAT or IRATA standards for safe access strictly by rope suspension. Personnel should be trained and experienced in the evaluation of rope access equipment and systems, be able to perform access techniques, and be competent in rescue procedures.

Specific areas of training and certification should include:

- Safety standards and documentation
- Methods of access
- Care, inspection, use, and limitations of equipment
- Knots
- Rigging
- Anchoring
- Ascending and descending
- Rope-to-rope transfer
- Structure climbing
- Assessing risks
- Self and co-worker rescue

4.1.4. OSHA 30

The OSHA 30 program provides training in general safety practices for construction and industrial environments.

Specific areas of training are:

- OSHA standards for hazardous conditions and practices
- OSHA's general safety and health provisions
- Occupational health and environmental controls
- Personal protective equipment
- Fire protection and prevention
- Rigging
- Welding and cutting
- Electrical standards and hazards
- Scaffolding
- Fall protection
- Excavations
- Concrete and masonry
- Decommissioning and demolition
- Ladders
- Hazards of confined spaces

4.1.5. First Aid/CPR

Due to the fact that most wind farm sites are in remote areas, it is critical that all field personnel be trained as first responders in applying first aid and CPR. OSHA or American Red Cross guidelines should be followed so that personnel can recognize and care for a variety of first aid emergencies and perform CPR and care for breathing and cardiac emergencies.

4.1.6. Confined Spaces and Respirators

Working within the rotor and especially inside of wind turbine blades require personnel to be trained in confined space access and the proper use of respiration gear. Training and certification for personnel should be done in accordance with OSHA 29 requirements and include areas such as:

- Confined space identification
- Hazard evaluation
- Behavior of gases
- Oxygen deficiency
- Equipment use and care
- Respirator fit
- Ingress and evacuation

4.2. Skill Levels

Blade repairs tend to fall under two primary divisions: cosmetic repairs and structural repairs. Care is needed in assuring that appropriate training and skill levels are available for either type of repair. A simple cosmetic repair, if not performed correctly, can result in a loss of generation power and potentially lead to additional repairs and failures. On-site or independent service providers have varied skill levels for various types of repairs. This can include not only the type of repairs, but also the blade access techniques, scheduling availability, and experience with various repair options and turbine platforms. Up front discussion on these points will prevent issues after a repair is contracted and started, e.g. an excellent team for changing out a pitch motor may not be the best choice for repairing a lightning strike repair.

Regardless of resources being used, accreditation through several programs and technical schools for composite repair should be part of the minimum acceptance level for skills to conduct on-site composite repairs. Such programs include ACMA CCT program for Wind Blade Repair. AWEA maintains a list of the wind turbine technical training schools.

4.3. Blade Repair Steps

4.3.1. Have an agreed plan on what inspections for damage are to be reviewed. This should be in written form and signed by all parties.

4.3.2. Obtain all background information on the damaged area. This should include any drawings, ply orientation, type of resin/adhesive, laminate schedule, and previous repairs.

4.3.3. Conduct a complete inspection of the damaged area. If appropriate, use remote viewing equipment or another safe approach to inspect the interior at the damaged location. The intent is to determine the size of the damage and potential repair prior to starting the repair process.

4.3.4. Once completed, obtain an agreement with site owners, site operators, and the repair team about potential repair options needed to correct the damage. Obtain agreement to conduct further inspection to ascertain the extent of the damage.

4.3.5. After cleaning the damage location, remove the exterior gel coat or paint system to obtain a complete visual for the damaged area. This should be done only with a fine grain abrasive.

4.3. Blade Repair Steps

(continued)

4.3.6. Once the entire area of repair has been exposed, the area should be marked and photographed and a detailed report on what steps and materials will be needed to complete the repair should be written. This should include measurements of the amount of scarf needed for each composite layer, the method of resin application to be used, the types of resin, and even the types of tools and processing aids to be used.

4.3.7. The site team, owners, and the repair team should have full agreement on the repairs based on this report prior to starting the repairs. This agreement may be used as the basis for the repair costs and repair warranty.

4.3.8. The repair team should document all steps in the repairs with photos and cite the processing steps and materials used. The approximate weight of the materials used is also of value.

4.3.9. The finished report on the damage and the repairs should be kept as a permanent part of the blade's maintenance record.

4.3.10. For repairs where no composite needs to be replaced, such as replacing a pitch motor, replacing surface mounted devices, or repairing a leading edge, the above mentioned steps of inspecting the damage, recording with photos, a written report with proposal options for repair, obtaining agreement on the repair and its timing and costs, followed by conducting the repair, documenting all steps to remove and replace the damaged components, and retaining the documentation with the maintenance records for the blade/rotor set should also be used.

5. Rotor Balancing

5.1. Expectation, Inspection, and Documentation

Most, if not all, blades are balanced and matched for a rotor set at the OEM location. Assuming that the set of blades remain a set on the turbine, the blades should be balanced.

Balanced rotor sets can lose balance by a change in material weight or by a change in material strength. It is recommended that inspections for rotor balance be made after a major composite repair or after noting differences in blade deflections within the rotor set at a given wind speed.

5.1. Expectation, Inspection, and Documentation (continued)

It is also possible to have a blade increase in weight due to moisture uptake from a porous gel coat, plugged drain hole, or prolonged exposure of blade core material to the environment, etc. This should also warrant an inspection of the rotor balance.

Dynamic balancing should be required any time a substitute blade is needed to complete/repair a rotor set.

As with all maintenance inspections and repairs, the balance measurements should be kept with the rotor set records for the life of the turbine. This should include the blade number, the location on the blade where weight was added, the amount of material added, and the final balance achieved.

5.2. Static and Dynamic Balancing

Static balancing should be kept to a minimum, with dynamic balancing desired. The blades arrive at the farm intended to be part of a balanced rotor set. Confirmation of this should be conducted prior to installing a rotor set. There are many views on balancing. A statically balanced rotor should be a balanced set but it does not mean that it is dynamically balanced. Only after being assembled and hung can the set be tested for its dynamic balance. There are varied ways to determine if the rotor set is out of balance, including auditory, “bumping” the set on a windless day, and correlating data as to which rotor sets are always last to spin up in light winds.

Upon finding a rotor set which needs to be brought into balance, weight should be added to the lightest blade. Weight should never be removed from the heaviest blade. Many OEMs build into the blades “weight boxes”. These confined spaces along the blade are intended to be used for the infusion of dense curable resins to adjust the balance as needed without having weights break free and rotate within the blade and/or reduce the structural strength of the blade.

6. Things to Avoid

When inspections indicate the need for repair, do not unduly delay the repairs. Added costs to make repairs to blades as the need for repair grows may eliminate the ability of the blade to be repaired, e.g. a blade in need of repair where moisture is allowed to egress into the blade core materials could potentially make the blade repair costs higher than the cost of total blade replacement.

7. Additional Suggestions

Conduct site visual inspections with high speed video/camera, telephoto lens, and laser pointers. Lag measurement of blade tip can be an indicator of trailing edge split. Tip offset from tower can indicate shear web weakness, stress cracking near root, or pitch imbalance. Use such low cost internal audits to evaluate the scope of the need for external evaluations and repairs.

Require dynamic balance information on all new installs after the rotor set is installed. Confirm that the information is still within the specification limits.

Keep repair records for all forms of repairs to each blade.

Require of OEM all repair information on any post fabrication repairs. This should include the location and type of repair, method to repair, and materials used to repair. This would include all repairs conducted as the results of transportation, storage, and installation prior to commissioning. This would also include all NCRs (non-conforming reports) from manufacturing.

Request lightning protection system readings recorded from manufacturing.

RP 302 Rotor Hubs

The following recommended practice (RP) is subject to the disclaimer at the front of this manual. It is important that users read the disclaimer before considering adoption of any portion of this recommended practice.

This recommended practice was prepared by a committee of the AWEA Operations and Maintenance (O&M) Committee.

Committee Chairs:

Jim Sadlo, 3M

Gary Kanaby, Wind Energy Services

Principal Author: Jim Sadlo, 3M

Purpose and Scope

The scope of “Rotor Hubs” addresses proper purchase, transportation, maintenance, repairs, and balancing of wind turbine rotor hubs.

Introduction

The purpose of this document is to provide turbine manufacturers, owner/operators, and independent service providers in the wind energy industry with a description of the best maintenance, inspection, and repair practices for the rotor hubs employed on wind turbine rotors. These best practices are to serve as a guideline with the understanding that economics will drive the actual implementation decision at each individual wind farm.

1. Inspections

1.1. Areas of Inspection

Hubs need to be checked in detail and their condition is to be documented. Irregularities and damages are to be detected and a recommended repair date specified. The hubs need to be checked in detail by a reputable technical expert. Scope and type of inspection are taken from the following table. (See *Table A*)

1.1. Areas of Inspections
(continued)

Table A. Areas of Inspection.

| Component to be Checked | Type of Inspection and Checkpoints | Minimum Inspection Frequency Every Year* |
|--------------------------------|--|--|
| Hub | Visual for cracks, paintwork, corrosion | <i>*Selected inspections may be needed after environmental incident events. Lightning storms, severe winds, hail, etc.</i> |
| Drive Shaft Slow Side | cracks, paintwork, corrosion, slipping clamping ring | |
| Bolted Joint Shaft – Hub | corrosion, crack, mounting torque | |
| Spindle | cracks, paintwork | |
| Rotor Bearing | noise, leakage, greasing, sump pan, lightning protection system, shaft nut | |

1.2. Pre-Purchase Audit

In addition to the inspections listed above, documentation on the hub should include conformity to the manufacturer’s engineering drawings.

1.3. Environmental Incident Inspection

Immediately following an environmental incident a ground based visual inspection for obvious hub damage should be conducted. Based on those observations additional inspections from the list above should be conducted.

1.4. On-going Inspections

Part of a consistent O&M recommended practice is to have a documented on-going inspection plan where all turbines are inspected on a regular basis. Extra inspections on problematic hubs are highly recommended as are higher inspection rates on previously repaired hubs.

1.5. Pre-End of Warranty Inspection

The key to the end-of-warranty inspection is to plan well ahead of the end-of-warranty in order to better plan out this inspection. Planning ahead is important because a single inspection may require a follow up inspection prior to bringing any warranty issue to the OEM before the warranty period is completed.

2. Transportation and Storage

2.1. Transportation

All hubs need to be shipped in compliance with the OEM transportation specification. Recommended practice would be to have this specification on-site prior to the shipping of the blades to ensure that all specifications are met, and in case any conflicting issues arise that deviate from this specification. Specific things to inspect are the bracing and support of the hub. Inspect for proper sealing and measures to ensure rust prevention during the transportation.

2.2. Storage

Storage of hubs needs to be different for the intended length of storage. Short periods of storage, such as staging for installation, can be varied as long as the blade is not exposed to undue mechanical strain or an environment that would compromise the exterior structure of the hub. Long term storage needs to address the following:

- Protection from UV light
- Metal surfaces from moisture
- Hub protected from rain, dust, and foreign objects, including small animals and insects from entering the interior of the hub
- Hub properly secured to the ground to prevent damage in high winds
- Hub properly supported and allow for the periodic rotation and lubrication of the bearings within the hub

3. Maintenance

As list in the table above, the inspections on the hub components should be part of the preventative maintenance schedule. The lubrication schedule should be based on the OEM recommendations.

4. Repair

All repairs where under warranty or past the warranty period should be conducted with OEM approved materials. The primary key to all repairs are to return the hub to the same physical strength, shape, and weight as it was commissioned.

RP 304 Rotor Lightning Protection Systems

The following recommended practice (RP) is subject to the disclaimer at the front of this manual. It is important that users read the disclaimer before considering adoption of any portion of this recommended practice.

This recommended practice was prepared by a committee of the AWEA Operations and Maintenance (O&M) Committee.

Committee Chairs:

Jim Sadlo, 3M

Gary Kanaby, Wind Energy Services

Purpose and Scope

The scope of “Rotor Lightning Protection Systems” addresses proper maintenance and testing of wind turbine rotor/blades lightning protection equipment.

Introduction

This section contains recommendation in how to secure that a specific lightning protection system in a blade or in a complete rotor and hub system is maintained in a reasonable manner. The information in this section should give the reader an understanding of where to focus and what kind of documentation that gives the requested certainty in the provided system. The recommendations given in this section are based on general requirements given in the standard “*IEC 61400-24 Wind Turbine System - Part 24: Lightning Protection*” governing requirements for lightning protection of wind turbines and are based on the state-of-the art in the wind turbines industry.

Wind Turbine Rotor Lightning Protection Systems

1. Inspections

The standard IEC 61400-24 requires regular inspections during the lifetime process of the wind turbine to secure the following:

- The LP system conforms to its original design and functionality
- All parts of the LP system are in good conditions and still capable of protecting the wind turbine with required performance until next scheduled maintenance

1.1. Inspection Intervals/Events

The inspections should, at a minimum, be performed on the following occasions:

- During production
- On-site before installation
- During installation
- After final commissioning of the wind turbine
- Scheduled inspections
 - Annual visual inspection
 - Bi-annual full inspection
- After extensive repair situations
- After severe lightning strikes

1.2. Pre-Purchase Audit

During the pre-purchase phase the buyer, or an inspector representing the buyer, must get a general understanding about the lightning protection philosophy covering the rotor and hub.

The producer must present how the overall lightning protection system is expected to work and how the lightning protection concept has been verified.

Detailed design documentation should be provided. This design must secure high efficiency in lightning interception and the rotor must be capable of withstanding the physical effects of lightning without catastrophic failures.

The blade lightning protection system should comprise an adequate tip section protection including protection of internal conductive and semi-conductive parts. Test reports and other kinds of verification must be presented to document the desired protection performance. The down conductor system must be able to handle impulse current of at least 200kA at 10/350 μ s (lightning protection level 1 in accordance with IEC 61400-24) without signs of internal arcing and without temperatures exceeding critical levels in relation to conductor isolation and GFRP/CFRP materials in general. In case of semi-conductive materials, such as carbon fibers, or other conductive elements such as sensors, heating elements, actuators etc., installed in the blade, it must be ensured that the presence of these systems and components are not compromising the safety and functionality of the blade.

Arc Entry tests must document the design lifetime of the air termination points (receptors).

1.2. Pre-Purchase Audit

(continued)

In blades with a lightning current transfer system located in the root section to protect the pitch bearings and drive train against lightning current penetration, these transfer systems must be designed in a robust way to secure mechanical stability and good lightning current carrying capability. It must be documented that the designed solutions have the desired function and lifetime performance.

In or around the hub section the lightning current path must be defined and secured such that no mechanical, hydraulic, or electrical components are exposed to direct or indirect lightning effect exceeding the withstand level of the component.

The inspector should audit the production facility to verify that the actual system is produced in accordance with the provided design. Lightning Protection Systems can be very different and the inspection points may be different from one system to another. It is important to define the inspection points as soon as the lightning protection concept is known.

For all blade lightning protection systems it is important that connections between different conductors are performed correctly. It is important that the right tooling and instructions are available in production. In cases with bolted connections that are not visible for inspection during the blade lifetime, these connections must be locked in a way that secures a good connection during the entire lifetime.

All connections must be checked by measuring the resistance before the connection is covered by resin or the blade mold is closed. Resistance measurements must be performed with a calibrated '4-point measuring method' instrument and all individual sub-connections must demonstrate resistances below 1 m Ω .

Finally, the entire lightning protection system must be checked by resistance measurement and the threshold value for the entire system must be defined by the natural resistance in the down conductor system added to the resistances in the connections in the system.

A good rule of thumb is to have 0.5 m Ω per meter blade length in total resistance. If this cannot be demonstrated the reasons must be sorted out and it must be decided by the inspector if the system can be accepted.

A diagram indicating the resistances in the system should be provided as a part of the blade documentation and all measurement data must be stored in the blade production file and made available for the inspector at any time.

1.3. During Production

During production, all conductors and connections must be inspected for correct installation. Resistance measurements must be taken regularly to ensure that all connections demonstrate low resistance values.

Attention should focus on electrically isolating materials (resin, sealing compound, etc.) used on electrical connections.

The lightning protection systems must be checked by measurement before the blade is closed or infused, depending on the production method. It is recommended that the resistances in the system are measured regularly during the production to make sure that no surprises occur.

Before the blade leaves production, the total resistance in the system must be measured and must still be within the tolerable range.

1.4. On Site Prior to Installation

Before the blade is installed on site, the total resistance in the system must be measured and must still be within the tolerable range. All connections must be inspected and the desired resistances in the system must be documented by measurement. Measurements are taken from the blade root termination point to all air termination points (receptors) in the system. (See *Figure A*) All measurements must be stored in the blade file.

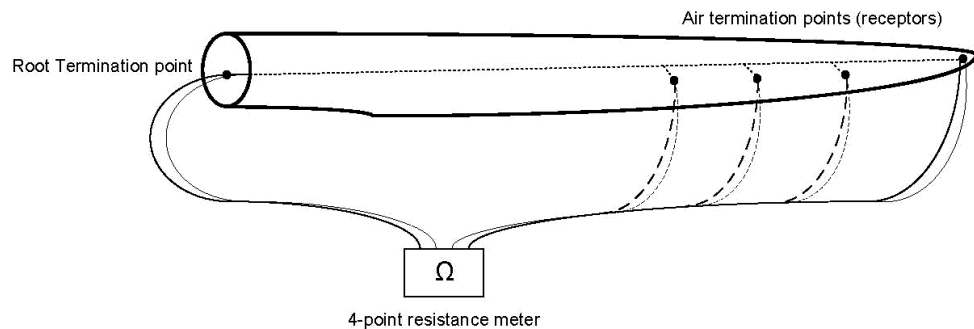

Figure A: 4-point Resistance Measurement From Root Termination Point to Air Termination Points (Receptors).

1.5. During Installation

SAFETY NOTE: Installation work cannot be carried out during thunderstorms. The risk of strikes to the turbine has to be considered by the site responsible person and no persons are allowed in the uncompleted turbine in the event of a lightning strike.

During installation of the rotor it is important to connect the lightning protection system to ground as early in the process as possible.

SAFETY NOTE: It has to be realized that even without thunderstorm activity, the blade can be static electric charged during the crane hoisting and installation and the installation crew should be instructed how to approach the floating blade and un-grounded lightning protection system.

It is recommended to consider a solution ground the blade without the installation crew touching the blade, eventually by use of an isolated ground stick.

When the turbine is erected and the blades are installed, there is a risk of lightning strikes before the turbine is finally commissioned and put into operation. The turbine must be secured such that the lightning protection system is completed as soon as possible in the erection process to avoid human injuries or system damages. It is important that the main lightning current path from the blade lightning protection system to the hub/nacelle/tower and further to the foundation grounding system is established.

Verify by visual inspection and resistance measurements that all intended lightning protection connections are fully functional immediately after erection. All inspection instructions and checklists must be stated in the relevant erection manuals. Resistance measurement values must be noted in the turbine file.

During power and control cable installations in the hub, nacelle, and tower, consider how cables are grounded in case of an approaching thunderstorms. Cables that are left unconnected and ungrounded can introduce a significant risk of flash-overs and damages to cables and equipment. Electrostatic discharges may occur and personnel may be injured.

1.6. After Final Commissioning of the Wind Turbine

After the turbine has been commissioned the lightning protection system must be checked before the turbine is put into operation. All connections must be inspected and the desired resistances in the system must be documented by measurement. Measurements are taken from the blade root termination point.

1.7. Scheduled Inspections

According to IEC 61400-24, the lightning protection system must be inspected every year of operation. Every year the lightning protection system must be inspected visually, and every second year the inspection should be extended to cover a full inspection, including continuity measurements and an in-depth inspection.

1.8. Yearly Visual Inspection

During the yearly visual inspection, the following points should be inspected:

- Root termination point: no broken/loosened parts
- Connection to pitch bearing, if relevant
- Cable connection: no broken/loosened parts
- Lightning Current Transfer System, if installed
 - Mechanical parts: no broken/loosened parts
 - Electrical parts, cables, brushes, etc.: no broken/loosened/worn parts
- Lightning registration card changed, if installed

1.9. Bi-annual Full Inspection

During the yearly visual inspection the following points should be inspected:

- Root termination point: no broken/loosened parts
- Connection to pitch bearing, if relevant
- Cable connection: no broken/loosened parts
- Lightning current transfer system, if installed
 - Mechanical parts: no broken/loosened parts
 - Electrical parts, cables, brushes, etc.: no broken/loosened/worn parts
- Lightning registration card changed, if installed

1.9. Bi-annual Full Inspection

(continued)

- Measurement of resistance in the following connections:
 - Root termination point to all air termination points (receptors)
 - Connection from root termination point to nacelle
 - External grounding systems to neutral, distant ground

1.10. After Extensive Repair Situations

After events with extensive repairs where the blade has been taken down, the lightning protection systems must be inspected again. The same procedure as described in Steps 9.2.2, 9.2.3, and 9.2.4 must be followed before, during, and after the blade re-installation.

1.11. After Severe Lightning Strikes

In the event of a severe lightning strike, an inspection of the entire lightning protection system must be considered. If there are no defects observed, the turbine operation should be continued. However, it can be expected that delayed failures will show up in the weeks/months after the strike.

If the lightning strike causes damage that requires a repair to the blade laminate, lightning protection system, the lightning current transfer system, etc., the repair must be followed with a resistance measurement to ensure that a tolerable resistance is maintained after the repair.

It is important to ensure that the conductors and connections inside the blade are repaired in the right way for proper function.

In cases with regular damage caused by lightning strikes, improvements to the lightning protection efficiency should be considered as a goal in the repair.

In severe cases, improvements should be installed proactively, but only improvements that are proven and verified to have a higher performance should be installed.

2. Maintenance

3. Repair

All repairs where under warranty or past the warranty period should be conducted with OEM approved materials. The primary goal of all repairs is to return the lightning system to the same performance characteristics as when it was commissioned.

4. Additional suggestions

Request references verifying previous experience in performing the type of necessary repairs from potential vendors

Investigate variances between the intended repair processes and those recommended by the component supplier or the OEM.

Chapter 4 Towers



Operations and Maintenance
Recommended Practices

version 2013

RP 401 Foundation Inspections, Maintenance, and Base Bolt Tensioning Procedures

The following recommended practice (RP) is subject to the disclaimer at the front of this manual. It is important that users read the disclaimer before considering adoption of any portion of this recommended practice.

This recommended practice was prepared by a committee of the AWEA Operations and Maintenance (O&M) Committee.

Committee Chair: Oliver Hirschfelder, Capital Safety
Principal Author: Jesse Tarr, Wind Secure

Purpose and Scope

The scope of “Foundation Inspections, Maintenance, and Base Bolt Tensioning Procedures” addresses the common maintenance issues related to foundation inspections, maintenance, and base bolt tensioning procedures. It is not machine specific and some adaptation may be required based on specific designs.

Introduction

The operation of a wind turbine generator and the resulting stresses to the foundation make routine inspections and testing essential to maintaining the structural integrity of the turbine. The recommended practices for foundation maintenance contained in this section pertain to inverted T spread footings with a peripheral arrangement of anchor bolts holding the tower to the foundation in tension. It should be noted that the vast majority of turbine foundations in North America are of this type. For turbines supported by different foundations, similar inspection and maintenance procedures can be implemented with some alterations depending on the circumstances.

Foundation Inspections, Maintenance, and Base Bolt Tensioning

1. Definitions

1.1. Anchor Bolt

The steel stud which attaches the tower base to the foundation.

1.2. Anchor Nut/Hex Nut

The anchor nut holds the tension load of the anchor bolt to the tower base flange.

1.3. Kip

A unit of force that equals 1,000 pounds.

1.4. PSI

A unit of force equal to 1 pound per square inch.

1.5. Diagram of Bolts/Tower Wall

(See Figure A)

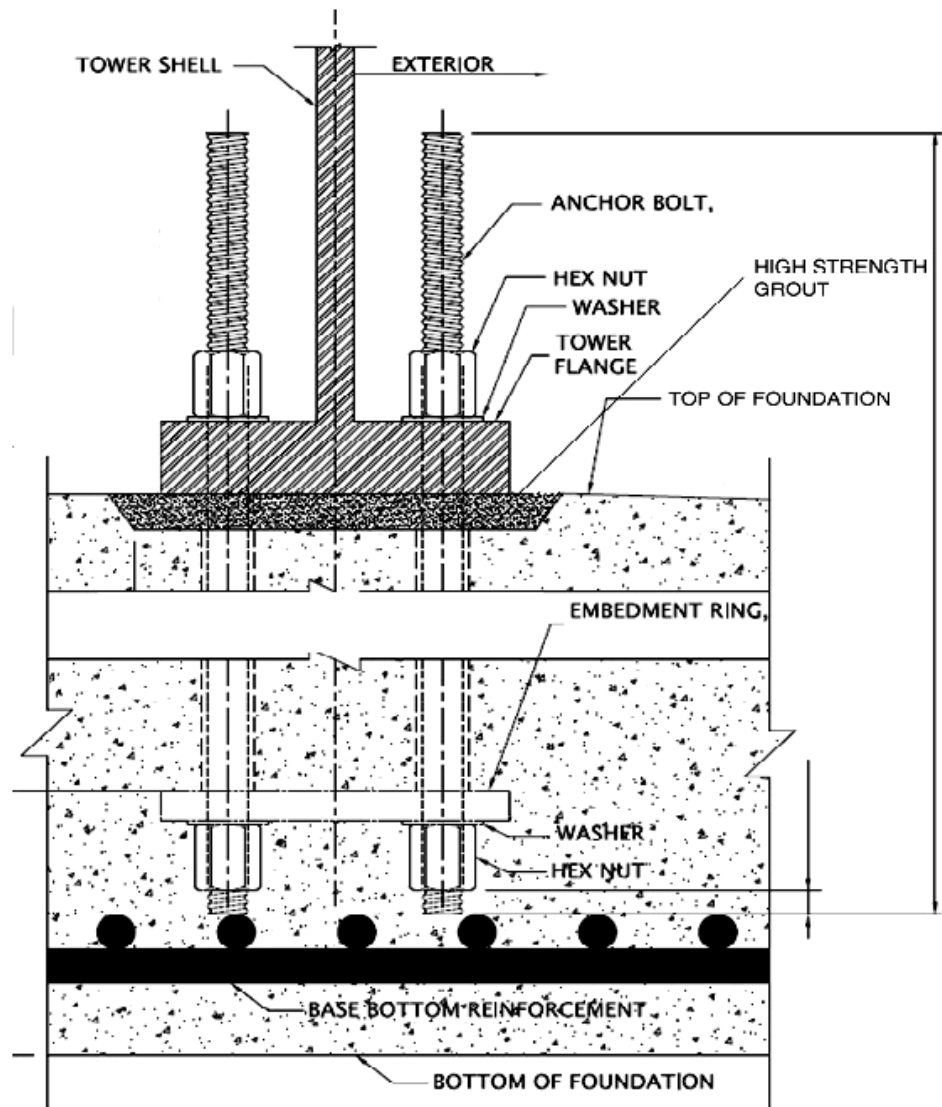

Figure A

1.6. Anchor Bolt Numbering Example Diagram
(See Figure B)

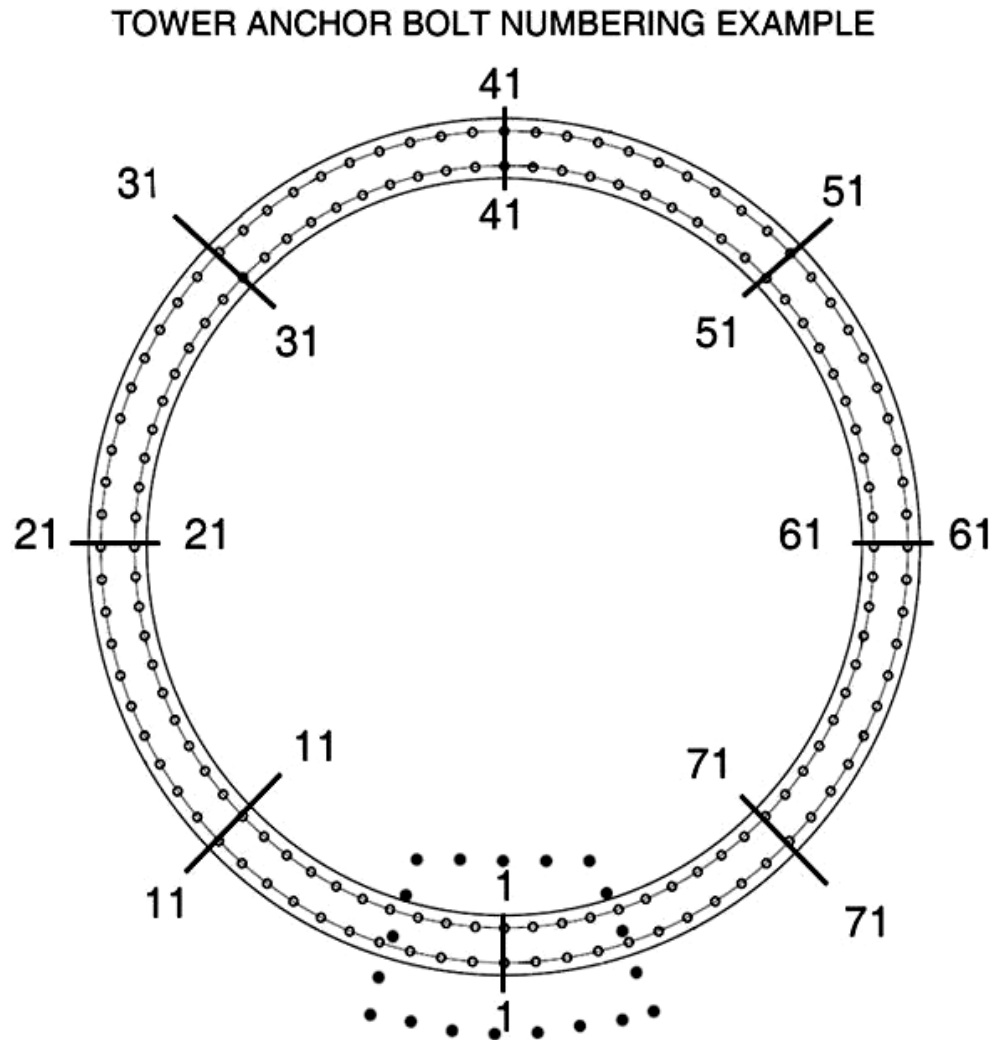

Figure B

2. Safety

2.1. Personal protective equipment (PPE) must always be worn while performing tensioning work. This includes, but is not limited to, hard hats, shatter-proof safety glasses, EH protected steel-toed work boots, leather gloves, and non-melting work clothing.

2.2. Equipment and tooling inspections should be performed before every shift. Run maximum daily pressure through tensioning system in controlled environment to check for leaks. Replace faulty components immediately if leaks are detected. Hydraulic oil injection into bloodstream is a major health and safety concern.

2.3. Follow OSHA guidelines for inspecting and marking all power tools, cords, ladders, etc.

2.4. If working conditions are classified as a confined space, all necessary measures must be followed to ensure a safe and proper work environment.

3. Inspections

3.1. Ten Percent Anchor Bolt Tension Inspections

Ten percent anchor bolt tension inspections are to be performed once a year for years 1-5 and every 5 years thereafter if all bolts pass final inspection. See Section 6: “*Ten Percent Tensioning Procedures*” for full description of procedure.

3.2. Grout and Concrete Inspections

Grout and concrete inspections are to be performed yearly on 100% of the turbines for the first 5 years of the project. After the 5 year benchmark, 50% of the turbines should be inspected yearly for the remainder of the project. If issues are discovered on any turbines during the inspections, 100% of the turbines should be inspected at that time. If cracking or spalling is discovered, it must be tracked and documented. If repairs are necessary, perform them immediately or they will likely worsen. If inspections reveal cracking or spalling of the concrete or grout, seal them immediately with an approved sealant. Monitor and document every 4 months from then on to ensure issues do not worsen.

3.3. Anchor Bolt Corrosion Inspections

Anchor bolt corrosion inspections should be performed in conjunction with grout and concrete inspections. Inspect for corrosion of interior and exterior anchor bolts, nuts, and washers. If corrosion is present, note and rectify immediately with approved greases or anti-corrosive coatings. **Treat corrosion as a foundation indicator.** If anchor bolts are excessively corroded, there is a high likelihood the nuts are seized to the bolt and the bolts are not holding proper tension.

3.4. Complete approved inspection documents for each turbine. These documents must reflect all relevant findings and data. The ability to reference historical documents can become an invaluable tool as the project ages.

4. Equipment

4.1. Tensioning system calibrations are to be verified 3 times daily when performing 10% tests and before every tower on 100% tensioning. As ambient temperatures rise and fall, it is likely that the temperatures of the hydraulic oil will change as well, possibly resulting in variable oil pressure needed to achieve the desired load. All calibrating machinery, including oil gauges, must have current certifications. If variations of more than 5% are detected during calibrations throughout the day, the previously completed tower should have 4 bolts tested at random to ensure they have been tensioned properly. If tests reveal loose anchor bolts, rectify as necessary.

4.2. Maintain pumps, jacks, and hoses in a controlled environment. Never store in freezing temperatures.

4.3. Keep working pumps in a controlled environment if ambient temperatures are below freezing. A heated van, box truck, or heated trailer are acceptable solutions for maintaining acceptable working temperatures of the pumps.

4.4. An oil pressure regulator should be utilized on the pump to ensure that the desired pressure is achieved each and every throw. Many pumps available today will push 20,000 PSI in as little as 3 seconds. At these speeds, discrepancies by the pump operator in fractions of seconds will result in thousands of pounds of differing tension. Setting the pressure regulator to a desired pressure, verified by the tensioning calibrator, is the only way to ensure the proper tension is applied to each anchor bolt every time.

4.5. The tensioning system must allow for visibility of the anchor nut and washer on the bolt being tensioned. The ability to observe the nut and washer lifting under tension and visually confirming that the nut has been properly tightened under tension is of utmost importance. Often times, on operational projects, nuts and washers corrode to each other and to the anchor bolt, thus requiring force to break them free. If anchor nuts are found to be sticky, two pancake jacks with a steel plate will allow for the throw of a large wrench. If nuts are moving freely, a single over-the-bolt tensioner will work fine, but it must allow for visibility of hardware for the reasons stated above. If the anchor nut and washer are not tight to the tower flange prior to releasing pressure from the tensioning system, the anchor bolt is not properly tensioned. Appropriate testing will reveal such issues.

5. Ten Percent Tensioning Procedure

- 5.1.** Approximately 1 year after the project has been 100% tensioned, 10% of the anchor bolts should be selected at random on 20% of the turbines. The testing value should be to the lowest specified engineered value. For example if the foundation drawings specify a tension of 75kips +5 -0 then all 10% testing is to be done at 75 kips.
- 5.2.** Anchor bolts should be numbered beginning with the bolt centered under the tower door as number 1, as in Figure B, with subsequent numbers in ascending order clockwise around the circumferences of the interior and exterior base flanges. The referenced bolt numbers should fall in the same position on every tower of the project.
- 5.3.** Two exterior/interior anchor bolts will be selected at random as a starting point. From the starting point, tension every 10th bolt until a minimum of 10% of the bolts have been tested.
- 5.4.** Every bolt tested must have visual confirmation from technicians that the anchor nut is tight to the flange prior to releasing tension from the jack(s). If nuts are sticky from corrosion, necessary means must be employed to ensure the anchor nuts are tight to base flange prior to releasing pressure from the tensioning system.
- 5.5.** Through performance documenting, outlined below, determine if the tower has passed or failed the tensioning check. If any singular anchor bolt is discovered to have an “as found” tension of less than 85% of the specified tension, it is to be deemed a failure and will require 100% of the anchor bolts to be tensioned on that tower following the procedure described in Section 7.
- 5.6.** If the population of tested anchor bolts has an average “as found” tension of less than 90% of the engineered specified value, that tower is to be deemed a failure, thus requiring 100% re-tensioning.
- 5.7.** If any of the foundations fail the 10% test, then all of the foundations on the project must be 10% tested.
- 5.8.** Repeat 10% tension check procedure as stated above on years 2 through 5 of the project. After year 5, when all of the foundations have been tested, and foundations have been properly tracked, revert to a 10% tension check on 20% of the project every 5 years for the remainder of the project, following the same pass/fail criteria. A different 20% of the foundations should be tested every year, so at year 5, all foundations will have been tested and documented.

5.9. Technician should sign interior tower basement wall under the doorway with initials, date, and description of work, i.e. 10% tension @ 75 kips, and company abbreviations.

5.10. Sample 10% tension testing report. (See Figure C)

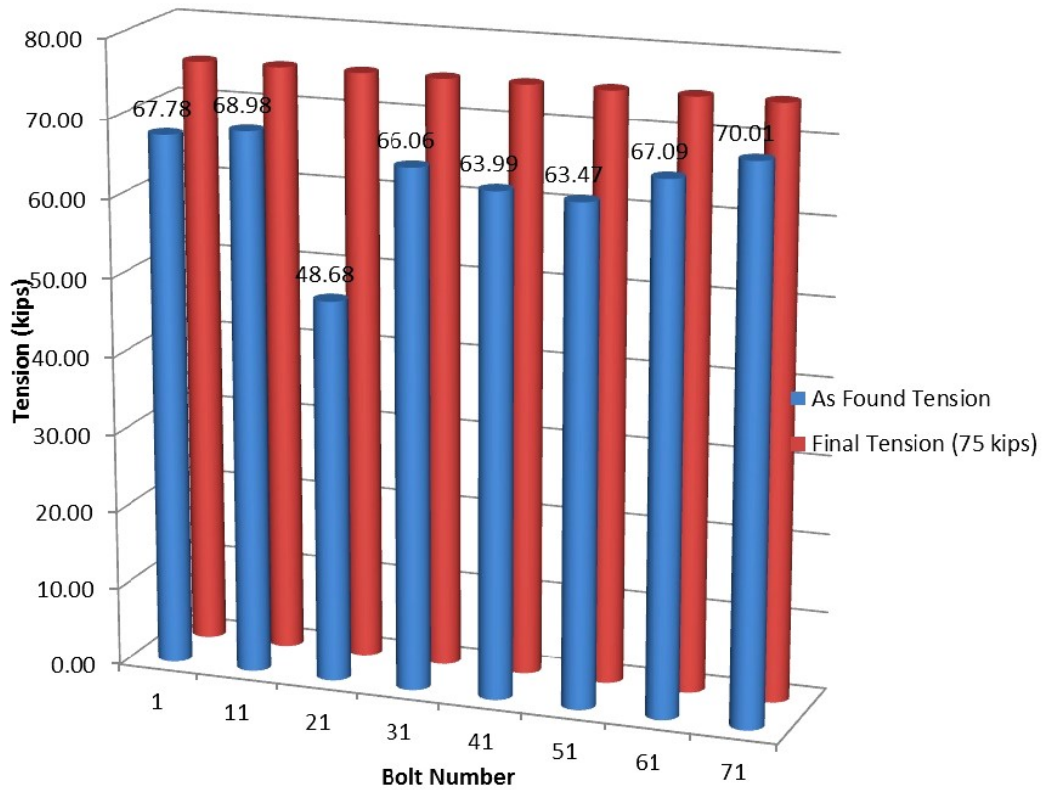

Figure C: As Found Tension (kips) vs. Final Tension (kips).

6. One Hundred Percent Tower Tensioning

- 6.1.** After construction has achieved final completion, a 100% anchor bolt tensioning should be completed within 6 months. It is important to record and document tension findings during this time.
- 6.2.** Number foundation anchor bolts with permanent paint pen on top of the bolt. Follow numbering sequence outlined in Section 6.2 and illustrated by Figure B.
- 6.3.** One hundred percent tensioning should be completed to the highest engineered specified value. For example, if the foundation drawings specify a tension of 75 kips +5 -0 then the 100% tensioning value is to be completed at 80 kips. Verify proper system calibration for every tower.
- 6.4.** Beginning at bolt 1, tension all anchor bolts in ascending numerical order around circumference of tower to desired tension.
- 6.5.** Repeat immediately on opposing flange.
- 6.6.** Technicians should sign interior tower basement wall under doorway with their initials, date, description of work, i.e. 100% tension @ 80kips, and company abbreviations.
- 6.7.** Accurately record and report findings for each anchor bolt tensioned. This condition monitoring information will be utilized for future evaluations of 10% checks and offer historical data for monitoring performance and identifying future failures before they happen. Anchor bolts that continually lose tension are indications of larger issues that include but are not limited to: grout failures, foundation failures, foundation settling, concrete shrinkage, chronic anchor bolt relaxation, poor previous workmanship, etc.

Summary

The forces that wind turbines endure from harnessing the wind causes continual strain to their foundations. Construction builds a stationary structure; operations maintain the working structures. As the wind industry matures there is a growing understanding of the importance to properly maintaining the foundations. The earlier an owner can start monitoring a foundation's performance, the higher the likelihood of identifying warranty issues now, and preventing costly issues later.

RP 402 Fall Protection, Rescue Systems, Climb Assist, and Harness

The following recommended practice (RP) is subject to the disclaimer at the front of this manual. It is important that users read the disclaimer before considering adoption of any portion of this recommended practice.

This recommended practice was prepared by a committee of the AWEA Operations and Maintenance (O&M) Committee.

Committee Chair: Oliver Hirschfelder, Capital Safety
Principal Author: Oliver Hirschfelder, Capital Safety

Purpose and Scope

The scope of “Fall Protection, Rescue Systems, Climb Assist, and Harness” addresses the common maintenance issues related to the grounding systems for generator and drive train shafts in various wind turbine designs. It is not machine specific and some adaptation may be required based on specific designs.

Fall Protection, Rescue Systems, Climb Assist, and Harness

1. Flexible Cable Ladder Safety System

1.1. Flexible cable ladder systems are designed to provide protection against falling for persons climbing vertical surfaces. These systems include installations on fixed ladders within the tower. The following inspection criteria is for user inspection and information purposes only. Formal inspections of ladder climbing systems must be conducted by personnel certified in their installation and inspection as required by the manufacturer.

2. Cable System Inspection

2.1. Inspect the top and bottom anchorage brackets for damage, corrosion, or rust. Look for cracks, bends, or wear that could affect the strength and operation of the system. Inspect for loose or missing fasteners; re-tighten or replace them if necessary.

2.2. Inspect the cable guides. Ensure the cable guide is not worn or bent, and still locks on the cable. Inspect for loose or missing fasteners; re-tighten or replace them if necessary.

2.3. Inspect the carrier cable for damage. Look for worn or broken cable strands. Inspect for signs of abrasion against the ladder or structure. The cable must not contact the ladder or structure. Replace damaged cable if necessary. Check the carrier cable tension, ensuring there is no slack, and re-tension the carrier cable if necessary.

2.4. Inspect the ladder structure for damage, rust, or deterioration that could affect the strength of the ladder.

2.5. Inspect the installation and service label. The label should be securely held in place and fully legible. Record inspection dates on the system label.

3. Ladder Safety Sleeve Inspection

3.1. Inspect the handle and cable shoe for bends, cracks, and deformation. All fasteners must be securely attached. Operation of the handle and cable shoe must be free and smooth. Spring must be secure and of sufficient strength to pull the handle.

3.2. Inspect the locking lever for smooth operation, ensuring it springs back into its locked position when released.

3.3. Inspect the sleeve body for wear on the inside where the cable passes through.

3.4. Inspect the rollers and the upper roller extension. Ensure the rollers spin freely and the spring rotates the upper roller extension to the climbing position.

3.5. Inspect the gravity stop. Hold the sleeve upside down and ensure the gravity stop rotates into the locking position. It should not be possible to open the sleeve far enough to insert the cable.

3.6. Inspect all labels and markings. Check that labels and markings are fully legible.

4. Rescue Device

4.1. Inspect for loose screws and bent or damaged parts.

4.2. Inspect the side plates for distortion, cracks, or other damage.

- 4.3.** Inspect the rope for cuts, severe abrasion, or wear. Check for contact with acids or other chemicals.
- 4.4.** Inspect to make sure that the rope lies correctly in the pulley.
- 4.5.** Inspect the contact surface of the drum for any sign of wear or strain. Check for distortion in the top loop.
- 4.6.** Do not disassemble the rescue block. It is not user serviceable.
- 4.7.** With the unit properly mounted from any sturdy structure, test the functional load.
 - 4.7.1.** Make sure that the rope drum locks in the clockwise direction (reverse lock operative).
 - 4.7.2.** Make sure that the rope drum rotates freely in the counter-clockwise direction (reverse lock not operative).
 - 4.7.3.** Make sure the stationary pulleys can be inserted and the locking bolt locked and that the locking pins in the locked state protrude about 5/32".

5. Inspection Steps for Pulleys

- 5.1.** Inspect the pulleys to ensure that they are clean and free from grease.
- 5.2.** Inspect the contact surface of the pulleys for any sign of wear or strain. Check for distortion in connecting loops.
- 5.3.** Inspect side plates for distortion, cracks, or other damage.
- 5.4.** Make sure that the pulley can be rotated freely and without resistance. If inspection or operation reveals a defective condition, remove the rescue unit from service immediately.

6. Inspection Cable Sleeve

6.1. Frequency

6.1.1. Before each use inspect the detachable cable sleeve according to Sections 5.2 and 5.3.

6.1.2. Formal Inspection

A formal inspection of a detachable cable sleeve must be performed at least annually by a competent person other than the user. The frequency of formal inspections should be based on conditions of use or exposure, see Sections 5.2 and 5.3. Record the inspection results in an inspection and maintenance log.

6.1.3. After a Fall

A formal inspection of a detachable cable sleeve must be performed by a competent person other than the user. Record the inspection results in an inspection and maintenance log.

6.2. Inspection Guidelines For Cable Sleeve

For identification of the example components described in the following guidelines, see Figure A.

6.2.1. Inspect the handle (1E) and cable shoe (1H) for bends, cracks, and deformities. All fasteners must be securely attached. Operation of handle and cable shoe must be free and smooth. Springs must be secure and of sufficient strength to pull handle down.

6.2.2. Inspect the locking lever (1J) for smooth operation, ensuring it springs back into its locked position when released.

6.2.3. Inspect the sleeve body (1M) for wear on the inside where the cable passes through.

6.2.4. Inspect the impact indicator pin (1L). If the indicator pin is missing or damaged, the sleeve should not be used until the pin is replaced.

6.3. Inspect the energy absorber (1K) to determine it has not been activated. The energy absorber cover should be secure and free of tears or damage.

| | |
|---|------------------------|
| A | Cable |
| B | Upper Roller |
| C | Upper Roller Extension |
| D | Label |
| E | Handle |
| F | Carabiner |
| G | Lower Roller |
| H | Cable Shoe </td |
| I | Gravity Stop |
| J | Locking Lever |
| K | Energy Absorber |
| L | Impact Indicator Pin |
| M | Sleeve Body |

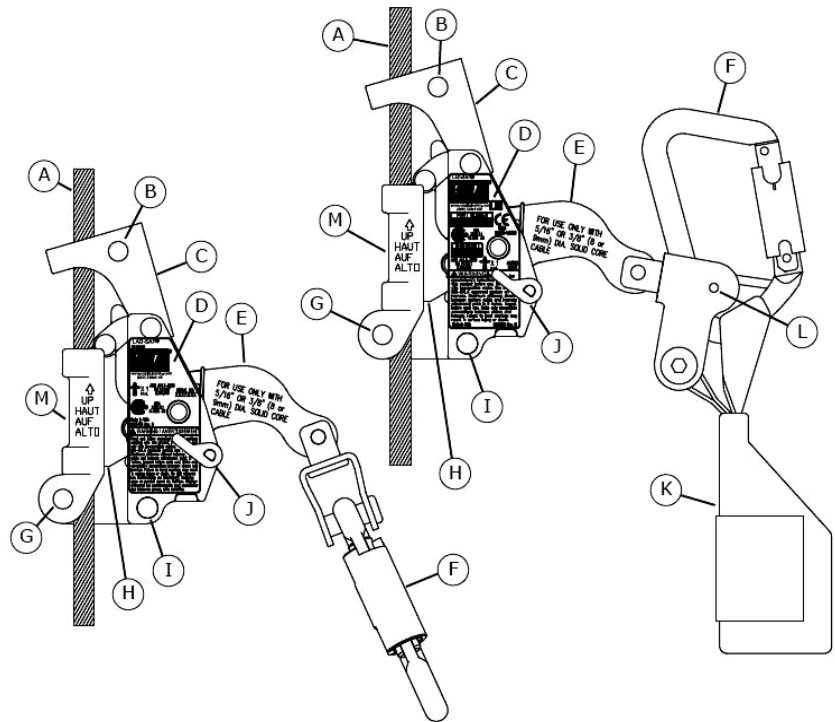

Figure A: Example of Safety Cable Device (Sleeve).

6.4. If inspection reveals an unsafe or defective condition remove the detachable cable Sleeve from service and destroy or contact an authorized service center for repair. Record the results in an inspection and maintenance log.

7. Inspection Climb Assist

7.1. Inspection Frequency

A portable motor control and cable grip must be inspected at the intervals defined by the manufacturer. Examples of inspection procedures are described in the example *Inspection and Maintenance Log* shown in Figure B. Inspect all other components of the Powered Climb Assist System per the frequencies and procedures defined by the manufacturer.

7.2. Defects

If inspection reveals an unsafe or defective condition, replace or repair the affected component(s) prior to further use of a powered climb assist system. Repairs must be performed by an authorized service center.

7.3. Product Life

The functional life of a powered climb assist system is determined by work conditions and maintenance. As long as the product passes inspection criteria, it may remain in service.

7.4. Cleaning

Cable grips may be cleaned using commercial parts cleaning solvents and rinsed with warm, soapy water. Light machine oil may be applied to moving parts if required. Do not use excessive oil or allow oil to contact cable clamping surfaces. Clean attached lanyards with water and mild soap solution. Rinse and thoroughly air dry. Do not force dry with heat.

IMPORTANT: If the cable grip or attached lanyards contact acids or other caustic chemicals, remove from service and wash with water and a mild soap solution. Inspect per Table 2 before returning to service.

| | | | |
|---|---|---------------------------|--------------------------|
| Serial Number(s): | | Date Purchased: | |
| Model Number: | | Date of First Use: | |
| Inspection Date: | | Inspected By: | |
| Component: | Inspection: (See Section 1 for <i>Inspection Frequency</i>) | User | Competent Person |
| Cable Grip (Diagram 1) | Inspect the Cable Grip for cracks, bends, or other deformities that might affect performance. The Handle (A) should be securely attached to the Sleeve (B) but should pivot freely around the Rivet (C). Teeth (D) should be present on the end of the handle that contacts the Wire Rope Cable. | <input type="checkbox"/> | <input type="checkbox"/> |
| | Marking on the Cable Grip must be legible. See the back pages of this manual for required markings and their locations. | <input type="checkbox"/> | <input type="checkbox"/> |
| Cable Grip Lanyards (Diagram 2) | If so equipped, inspect attached web lanyards for concentrated wear, frayed strands, broken yarn, burns, cuts, and abrasions. The lanyard must be free of knots throughout its length. Inspect for excessive soiling, paint build-up, and rust staining. Inspect for chemical or heat damage indicated by brown, discolored, or brittle areas. Inspect for ultraviolet damage indicated by discoloration and the presence of splinters and slivers on the webbing. | <input type="checkbox"/> | <input type="checkbox"/> |
| Portable Motor Control Unit (Diagram 3) | The Motor Control Unit Enclosure should be clean and free of cracks or other deformities that might impact performance of internal components. | <input type="checkbox"/> | <input type="checkbox"/> |
| | The Motor Control Unit Power Cord should be free of cracks or holes in the outer casing and frayed, broken, or exposed wires. Plug ends should be free of defects and appropriate for the designated power source. | <input type="checkbox"/> | <input type="checkbox"/> |
| | Plug the Power Cord into the Motor Control Unit and appropriate power source. Pull out the Emergency Stop Button. The lights on the control panel will flash momentarily and then the yellow Power Button (Ⓟ) light (A), first red Climb Assist Force light (B), and one of the green Motor Spin Direction lights (C) will stay lit. Verify that the correct Motor Spin light is lit for your Drive Bracket orientation. Press the Power Button (Ⓟ) and the Power Button light will switch from yellow to green. If the control panel lights do not illuminate in the described manner, consult the Troubleshooting Chart in Section 3.4. | <input type="checkbox"/> | <input type="checkbox"/> |
| | All labels should be present on the Motor Control unit and should be fully legible. See the back pages of this manual for required labels and their locations. | <input type="checkbox"/> | <input type="checkbox"/> |
| Other Components | Inspect the PCAS Brackets, Wire Rope Cable Loop, and Wear Pads per instructions in the "Installation and Maintenance Manual" (5903447). Inspect the Full Body Harness per the Manufacturer's instructions. | <input type="checkbox"/> | <input type="checkbox"/> |

Figure B: Example of Inspection and Maintenance Log.

7.5. Authorized Service

Additional maintenance and servicing procedures should be completed by a factory authorized service center. Authorization should be in writing. Do not attempt to disassemble and repair components of a powered climb assist system.

7.5.1. Storage

When not in use with a powered climb assist system, store motor control units and cable grips in a cool, dry, clean environment out of direct sunlight. Avoid areas where chemical vapors may exist. Thoroughly inspect components after extended storage.

8. Inspection of Full Body Harness

8.1. Frequency

Before each use inspect the full body harness according to the manufacturer's guidelines. The harness must be inspected by a competent person other than the user at least annually. A competent person is one who is capable of identifying existing and predictable hazards in the surroundings or working conditions which are unsanitary, hazardous, or dangerous to employees, and who has authorization to take prompt corrective measures to eliminate them. Record the results of each formal inspection in an inspection and maintenance log.

IMPORTANT: If the full body harness has been subjected to fall arrest or impact forces it must be immediately removed from service and destroyed.

IMPORTANT: Extreme working conditions (harsh environments, prolonged use, etc.) may require increasing the frequency of inspections.

8.2. Inspection

8.2.1. Inspect Harness Hardware (Buckles, D-rings, Pads, Loop Keepers, Vertical Torso Adjusters)

These items must not be damaged, broken, or distorted and must be free of sharp edges, burrs, cracks, worn parts, or corrosion. PVC coated hardware must be free of cuts, rips, tears, holes, etc., in the coating to ensure non-conductivity. Ensure that release tabs on buckles work freely and that a click is heard when the buckle engages. Inspect vertical torso adjusters for proper operation. Ratchet knobs should turn with ease in a clockwise direction and should only turn counter-clockwise when the knob is pulled out.

8.2.2. Inspect Webbing

Material must be free of frayed, cut, or broken fibers. Check for tears, abrasions, mold, burns, or discoloration. Inspect stitching; check for pulled or cut stitches. Broken stitches may be an indication that the harness has been impact loaded and must be removed from service. When performing the annual formal inspection, unsnap and open the back pad to facilitate inspection of the webbing.

8.2.3. Inspect the Labels

All labels should be present and fully legible.

8.2.4. Inspect System Components and Subsystems

Inspect each system component or subsystem according to manufacturer's instructions.

8.2.5. Record Inspection Data

Record the inspection date and results in an inspection and maintenance log.

8.2.6. Inspect the Stitched Impact Indicator

The stitched impact indicator, shown in Figure C, is a section of webbing that is lapped back on itself and secured with a specific stitch pattern holding the lap. The stitch pattern is designed to release when the harness arrests a fall or has been subjected to an equivalent force. If the impact indicator has been activated, the harness must be removed from service and destroyed.

8.2.7. Inspect Suspension Trauma Straps

Check the trauma strap pouches for damage and secure connection to the harness. Unzip the trauma strap pouch on each hip of the harness and inspect suspension trauma straps. Webbing and pouch material must be free of frayed, cut, or broken fibers. Check for tears, abrasions, mold, burns, discoloration, or knots.

IMPORTANT: If inspection reveals a defective condition, remove the unit from service immediately and destroy it.

NOTE: Only manufacturer or parties authorized in writing should make repairs to this equipment.

A. Stitched Impact Indicator

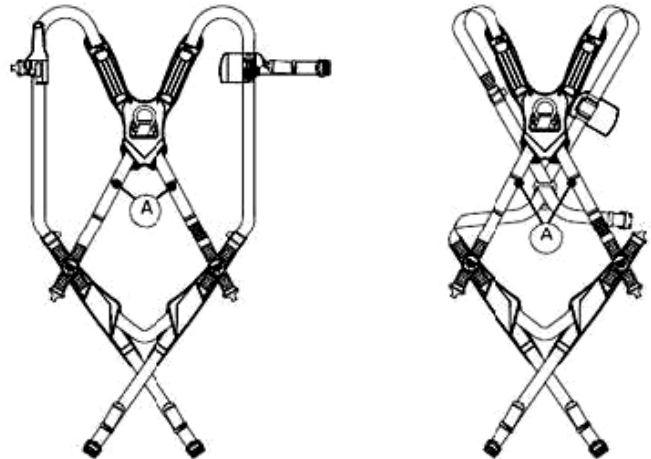

Figure C: Example of Stitched Impact Indicators.

8.3. Washing Instructions

Washing procedures for the full body harness are as follows:

8.3.1. Spot clean the full body harness with water and a mild soap solution.

IMPORTANT: Use a bleach-free detergent when washing the harness and pads. Fabric softener or dryer sheets **SHOULD NOT** be used when laundering and drying the harness and pads.

8.3.2. Water temperature for wash and rinse must not exceed 160°F (70°C).

8.3.3. The harness and pads may be air dried or tumble dried on low heat not exceeding 200°F.

NOTE: More information on cleaning is available from the manufacturer. If you have questions concerning the condition of your harness or have any doubt about putting it into service, contact the manufacturer.

8.4. Additional Maintenance and Servicing

Additional maintenance and servicing procedures should be completed by a factory authorized service center. Do not attempt to disassemble the unit.

8.5. Storage

Store the full body harness in a cool, dry, clean environment out of direct sunlight. Avoid areas where chemical vapors may exist. Thoroughly inspect the full body harness after extended storage.

RP 404 Wind Turbine Elevators

The following recommended practice (RP) is subject to the disclaimer at the front of this manual. It is important that users read the disclaimer before considering adoption of any portion of this recommended practice.

This recommended practice was prepared by a committee of the AWEA Operations and Maintenance (O&M) Committee.

Committee Chair: Oliver Hirschfelder, Capital Safety
Principal Author: Carisa Barrett, Elevator Industry Work Preservation Fund

Purpose and Scope

The scope of “Wind Turbine Elevators” addresses the common maintenance issues related to the wind turbine elevator. It is not machine specific and some adaptation may be required based on specific designs.

Introduction

Before installing, maintaining, and/or repairing any wind turbine elevators, check with the “Authority Having Jurisdiction” you are working in for permitting and inspection requirements. If they are regulated, all work must be performed in accordance with the adopted codes, rules, and regulations. Currently a majority of jurisdictions require conformance to ASME A17.1/CSA B44, Section 5.11. Companies should be cognizant that some jurisdictions do not have requirements and the elevators purchased may not conform to the new code requirements. Care should be taken to consider risks associated with this lack of conformance.

Excerpts from the ASME A17.1/CSA B44, Section 5.11

1. Elevator, Wind Turbine Tower

1.1. A hoisting and lowering mechanism equipped with a car installed in a wind turbine tower.

2. Part 5 Applies to Special Application Elevators as Specified in the Following Requirements:

(k) Section 5.11 applies to elevators used in wind turbine towers

3. Scope

Requirement 5.11 applies to elevators permanently installed inside an enclosed wind turbine tower to provide vertical transportation of authorized personnel and their tools and equipment for the purpose of servicing, maintaining, and inspecting wind turbine equipment.

Such elevators are typically subjected to extreme temperatures, humidity variations, and substantial horizontal motion where, by reason of their limited use and the types of construction of the structures served, full compliance with Part 2 is not practicable or necessary.

4. For More Information on this Standard or to Order a Copy of the ASME A17.1-2013/CSA B44-13 please contact:

ASME Order Department
22 Law Drive
Box 2300
Fairfield, NJ 07007-2300
Tel: 800-843-2763
Fax: 973-882-1717
E-Mail: infocentral@asme.org
ASME Website: www.asme.org/shop/standards

ASME is the registered trademark of The American Society of Mechanical Engineers.

Chapter 5 Data Collection and Reporting



Operations and Maintenance
Recommended Practices

version 2017

RP 502 Smart Grid Data Reporting

The following recommended practice (RP) is subject to the disclaimer at the front of this manual. It is important that users read the disclaimer before considering adoption of any portion of this recommended practice.

This recommended practice was prepared by a committee of the AWEA Operations and Maintenance (O&M) Committee.

Committee Chair: Bruce Hamilton, Navigant
Principal Author: Benjamin Karlson, Sandia National Laboratories

Purpose and Scope

The scope of “Smart Grid Data Reporting” focuses on generating, collecting, and serving up wind farm data for smart grid operation. This data can also be useful for power purchaser and owner/operator reporting.

Introduction

It is important that readers understand what is meant by smart grid in this context. A smart grid is a modernized electric grid that uses information and communication technology to gather and act on information in an automated fashion to improve the efficiency, reliability, economics, and sustainability of the production and distribution of electricity.

Smart Grid Data Reporting

1. Data Requirements

The most important characteristic of a smart grid is the ubiquity of communication devices and the flow of information between all aspects of the grid including the generation, transmission, distribution, and end use. Under the current grid operations scheme (non-smart grid), grid operators need to know certain operating information of all generation. This includes, but may not be limited to, real power, reactive power, and bus voltage at the point-of-interconnection. Additionally, grid operators need to communicate to generators operation commands such as how much power the grid can accept, what voltage schedule to follow, etc.

1. Data Requirements

(continued)

The following was taken from NERC's "*Interconnection Requirements for Variable Generation*" report:

The following signals should be sampled at the normal SCADA (supervisory control and data acquisition) update rate:

- Active power (MW)
- Reactive power (Mvar)
- Voltage at the point-of-interconnection

The following wind plant status signals are also recommended but may be sampled at a slower rate:

- Number of turbines available (or total MW rating of available turbines)
- Number of turbines running and generating power (or total MW rating of turbines online and generating power)
- Number of turbines not running due to low wind speed
- Number of turbines not running due to high-speed cutout
- Maximum and minimum reactive power capability of plant (for some plants in weak grid locations, it would also be prudent to know how much of the total range is dynamic, as opposed to switched capacitors or reactors)
- Total available wind power (equal to production unless curtailed)
- Average plant wind speed (when wind speeds are high and increasing, operators could anticipate high-speed cutout actions)
- Plant main breaker (binary status)
- Plant in voltage regulation mode (binary status)
- Plant in curtailment (binary status)
- Plant up ramp rate limiter on (binary status)
- Plant down ramp rate limiter on (binary status)
- Plant frequency control function on (binary status)
- Plant auto-restart blocked (on/off)

A fully realized smart grid will incorporate a two-way flow of real-time information from generation to consumption.

Current data requirements needed from wind power plants to grid operators are clarified under the IEC 61400-25 communication standards. This standard provides a basis for the interoperability of SCADA systems and addresses the communication between SCADA systems installed on wind power plants and the grid operations centers that can benefit from the SCADA data.

1. Data Requirements

(continued)

The IEC 61400-25 Edition 1 (2008) standard has not been widely adopted yet; however, as smart grid initiatives move forward, grid operators should adopt this standard as a means of facilitating communication and interoperability. Wind power plants interconnecting to the grid will have different data requirements as defined by the specific transmission owner with which the wind power plant is interconnected.

1.1. Phasor Measurement Units

Phasor measurement units (PMUs) are devices that measure the signals on the bulk electric grid using a synchronized common time source. If installed, they are installed on the grid side of a wind power plant point-of-interconnect (POI) and monitor in real-time the state of the electric grid. These units monitor voltage and current many times a second, typically 30 samples/second, allowing for fast response dynamic adjustments to be made on the grid providing for stability and reliability. This high frequency monitoring of wind power plants will enable better regulation and coordination of all interconnected generation.

Because PMUs are connected to the grid side of the POI of a wind power plant, they are typically owned and maintained by transmission operators, though any wind power plant that opts to purchase and install a PMU should provide access to this data to grid operators.

1.2. Forecasting

Because the power output of a wind power plant is a direct function of the wind speed and the weather is an ever-changing system, the wind forecast, and thus the wind power plant generation forecast, play an important role in grid system operations. This forecast combined with the load forecast enables grid operators to commit generation resources on a day-ahead schedule allowing the system to be maintained economically and securely.

For detailed information regarding wind power plant forecasts see RP 504 on Wind Forecasting Data.

1.3. Active Wind Plant Control

As the smart grid initiative progresses it will become imperative that wind power plant's control systems are able to respond to signals sent from grid operators to actively control the operation of the wind plant. This might include reducing or increasing real power or reactive power, controlling the ramp-rate of the plant, or providing frequency regulation as requested by the grid. However, because today's wind power plants are typically operated to maximize power output, they may face an economic penalty for operating in a different state.

References

- [1] "The Smart Grid: An Introduction," Litos Strategic Communication, New Bedford, MA, USA, Prepared for the U.S. Department of Energy under contract No. DE-AC26-04NT41817, Subtask 560.01.04, 2008.
- [2] "A Smart Grid Strategy for Assuring Reliability of the Western Grid", The Western Electricity Coordinating Council, 2011.
- [3] "Advancement of Synchrophasor Technology" Oak Ridge National Laboratory, Oak Ridge, TN, USA, Prepared for the U.S. Department of Energy's Office of Electricity Delivery and Energy Reliability, 2016.
- [4] "2012 Special Assessment, Interconnection Requirements for Variable Generation", NERC, Atlanta, GA, USA, 2012.
- [5] K. Johansen, "Presentation of IEC 61400-25 work: 'A generic communication solution for Wind Power Plants'", presented at JWPA, Denmark, 2009.

RP 503 Wind Turbine Reliability

The following recommended practice (RP) is subject to the disclaimer at the front of this manual. It is important that users read the disclaimer before considering adoption of any portion of this recommended practice.

This recommended practice was prepared by a committee of the AWEA Operations and Maintenance (O&M) Committee.

Committee Chair: David Zeglinski, OSIsoft, LLC
Principal Author: Roger R. Hill, Sandia National Laboratories
Contributing Author: Dave Ippolito, Versify

Purpose and Scope

The scope of “Wind Turbine Reliability” focuses on data collection and the metrics for reporting and understanding overall plant reliability performance.

Introduction

The owner/operator bears the responsibility for collection of data and information for purposes of running the wind plant in a reliable and profitable manner. Reliability status reporting will be seen as failures, corrective and preventative maintenance, SCADA (time series) reporting, events, alarms, failures, MTBE, MTBF, downtime, maintenance costs, computerized maintenance management reporting (CMMS), and condition monitoring functions.

The following discussion recommends practices for data collection and the metrics for reporting and understanding of the overall plant reliability performance. Reliability, availability, and maintainability (RAM) metrics will have a role in this. RAM metrics provide reliability and availability trends, causes, sources, reasons, and impacts for plant downtime at the component level and provide field performance.

A subset of the data from every turbine’s control system, as well as data collected at the metering, substation, and grid connection interface, is typically held in one or more of the plant-wide supervisory control and data acquisition (SCADA) systems.

Introduction

(continued)

The O&M function is focused on maintaining generation at high levels and conducting preventative and corrective maintenance of the turbines, their components, and balance of plant. Production data by turbine should be maintained and analyzed for purposes of production engineering, which is important to overall plant O&M function.

Table A

| | |
|-----------------|--|
| kWh | Daily, weekly, quarterly, annually |
| Stop Hours | Daily, weekly, quarterly, and annually |
| Capacity Factor | Daily, weekly, quarterly, or annually |
| kWh/kW | |

Wind Turbine Reliability

1. Event Data

Event data is needed to answer the basic questions of how often something fails, how long is it out of operation, and how much the down time costs. In other words, the symptoms, cause, and corrective actions for any failure or maintenance activity is a need that must be determined.

A record of each downtime event should be made.

Table B

| | |
|----------------|---|
| Turbine ID | Distinguishes individual turbines |
| Event Code | Unique identifier for type of downtime event |
| Fault Code | Automated SCADA code that initiated the event |
| Event Name | Descriptive label for type of downtime event |
| Event | Start date and time |
| Event Type | Type of downtime (e.g., failure and preventative maintenance) |
| Event Duration | Hours of downtimes/return to service |

It is important to track these metrics to individual components so that O&M planning, parts inventory and orders, manpower and equipment, and maintenance scheduling can be done as efficiently as possible.

2. Computerized Maintenance Management System (CMMS)

Work orders are often generated by plant managers to capture the need for repairs or other types of maintenance. A work order may have multiple purposes. It may be used for tracking of human resources or for tracking the time the turbine spent offline. For purposes of reliability tracking, work orders should document the investigation into the cause of outage and which component failed and/or was replaced, i.e. the root cause. In this way, work orders may provide insight into turbine performance and document operator actions which indicate the root cause of failure.

Ideally, work order systems will be computerized in an automated maintenance management system. Sandia has published a report entitled *Wind Energy Computerized Maintenance Management System (CMMS): Data Collection Recommendations for Reliability Analysis (SAND2009-4184)*. Combined SCADA and CMMS capabilities will enable reporting of recommended individual turbine metrics of:

- Operational Availability
- Wind Utilization
- MTBE (operating hrs.)
- Mean Downtime (hrs.)
- Annual Cost (per Turbine)
- Intrinsic Availability
- MTBF (operating hrs.)
- Mean Failure Downtime (hrs.)
- Annual Failures
- Failures Cost (per Turbine)
- Mean Fault Downtime (hrs.)
- Annual Fault Cost (per Turbine)
- MTB Scheduled Maintenance (operating hrs.)
- Mean Scheduled Downtime (hrs.)
- Maintenance Schedule
- Annual Scheduled Cost (per Turbine)

An ability to reconcile and harmonize SCADA and CMMS data is suggested as a recommended feature and capability for O&M and RAM functions in operating a wind plant. Getting organized to do this will provide tools to improve reliability and profits.

References

- [1] R.R. Hill, V.A. Peters, J.A. Stinebaugh, and P.S. Veers, "Wind Turbine Reliability Database Update Appendix B: Report Template for Individualized Reports to Partners," Sandia, Albuquerque, NM, USA, SAND2009-1171, 2009.
- [2] B.L. McKenney, A.B. Ogilvie, and V.A. Peters, "Using Wind Plant Data to Increase Reliability," Sandia, Albuquerque, NM, USA, SAND2010-8800, 2011.
- [3] V.A. Peters, P.S. Veers, and A. Ogilvie, "Wind Energy Computerized Maintenance Management System (CMMS): Data Collection Recommendations for Reliability Analysis," Sandia, Albuquerque, NM, USA, SAND09-4184, 2009.

RP 504 Wind Forecasting Data

The following recommended practice (RP) is subject to the disclaimer at the front of this manual. It is important that users read the disclaimer before considering adoption of any portion of this recommended practice.

This recommended practice was prepared by a committee of the AWEA Operations and Maintenance (O&M) Committee.

Committee Chair: David Zeglinski, OSIsoft, LLC
Principal Author: Jeff Erickson, Versify

Purpose and Scope

The scope of “Wind Forecasting Data” describes best practices for the data required for accurate, actionable wind forecasting.

Introduction

By its nature wind generation is variable, intermittent, and uncertain. Employing sophisticated, data-driven methods to increase forecast accuracy enables more efficient and reliable power system operations. Short-term forecasts can be used for turbine active control and dispatch. Mid-term forecasts and day ahead forecasts can be used for power system management and energy trading and unit commitment and economic dispatch (optimizing plant schedules). Long-term forecasts are often used for longer term scheduling and maintenance planning at a wind farm.

Wind Forecasting Data

1. Procedures (Detailed Descriptions)

There is an ever growing volume of data points available to wind forecasters. While more data often means more accurate forecasts, one must weigh the cost and complexity of data-intensive methods against the results derived from simpler methods.

At its most basic level, there are two forms and sources of data necessary for any useable wind forecast: static data, such as latitude and longitude of the wind plant and hub height, and dynamic data, such as the measurement of metered power output. Adding historical output increases the value of the forecast by allowing for an empirical relationship between forecasted wind speeds and power output.

1. Procedures (Detailed Descriptions)

(continued)

Moving down a level in granularity, additional data sources can help a forecaster increase accuracy. Tracking current availability, i.e. the number of wind turbines available now and the power generation characteristics of those turbines, allows for a power conversion analysis to calculate lost generation resulting from planned maintenance at the wind farm. Forecast availability, such as the number of wind turbines expected to be available in the future and the power generation characteristics of those turbines, can help in planning for power de-rates associated with a future maintenance schedule.

Curtailments, whether from system operator instructions or transmission issues, impact forecasts and should be integrated into the forecast analysis data, both for real time and historical purposes.

Data about the wind itself, both wind speed and direction can be leveraged to increase forecast accuracy. Depending on the forecast providers' methods, varying degrees of wind data will be required and the forecast user should consult with the vendor to determine how much and what type of data to collect. Often if wind data is used, it is considered after power, availability, and curtailment data. Wind data can be collected directly from on-site MET towers or can be based on averaging nacelle wind speeds across the plant. Again, it is recommended that the end user consult with the forecast provider to understand the methods used.

At the lowest level of granularity, turbine-level data can be integrated into the final analysis. Turbine level data is often used to predict ramp forecasts, such as large changes in output. On-site and off-site temperature, humidity, air pressure, wind speed, wind direction, and power make up this category of data.

While data collection and integration techniques can differ among forecasters, the next and most immediate challenge is in turning this data into usable, action-based knowledge for the wind operator. Intelligent and timely operator response to wind forecast data can result in significant monetary benefit to the generator operator. Everything from the effective unit commit and generation balancing, to understanding the economic impact of a curtailment, to efficient, cost-effective maintenance scheduling can be positively impacted by timely, appropriate operator action in response to wind forecasts.

2. Tools

Tools that provide a common and easy-to-use interface to forecast data and that can help direct an operator to an appropriate action are critical to the future integration of cost-effective wind integration.

Tools are available today that allow end users to integrate third party vendor wind forecasts so that meteorologists and planners may visualize third party data, create and shape their own internal ensemble forecast, and integrate those with trading and market systems.

Summary

In the near future, the ability to analyze wind forecasting models and provide insight into the best models under different weather conditions will provide end users insight into the forecast data they are buying. Inherently, this will help produce more reliable wind forecasts and allow for more aggressive scheduling and marketing of wind energy to optimize revenue.

RP 505 Asset Identification and Data Reporting

The following recommended practice (RP) is subject to the disclaimer at the front of this manual. It is important that users read the disclaimer before considering adoption of any portion of this recommended practice.

This recommended practice was prepared by a committee of the AWEA Operations and Maintenance (O&M) Committee.

Committee Chair: Bruce Hamilton, Navigant
Principal Author: David Zeglinski, OSIsoft, LLC
Contributing Author:
Alistair Ogilvie, Sandia National Laboratory
Ben Karlson, Sandia National Laboratory

Purpose and Scope

The scope of “Asset Identification and Data Reporting” focuses on generating, collecting, and serving up wind farm data for asset management and maintenance and reliability improvements. There are two key components: the metadata system associated with the generating assets and the data collection system itself.

Data Reporting

1. Metadata System

1.1. Develop a Detailed Taxonomy

Developing a detailed equipment breakdown, or taxonomy, helps ensure that maintenance data is captured with enough detail to be useful. Using a breakdown of the equipment that provides a unique assessment opportunity for each component or part ensures greater insight in determining which assemblies, subassemblies, or components significantly affect reliability and availability performance. For example, “Drivetrain-Gearbox-Bearings-Planetary Bearing” provides much more information than just “Gearbox”. Fortunately, with metadata software, this needs to be done only once for each equipment type. The elemental framework can then be copied for each turbine where only the turbine name or number is globally replaced as it is copied/duplicated.

1.2. Attend to the Details

With any data collection system, one of the biggest challenges is ensuring that data is entered for every applicable data field. In addition to entering all of the relevant information, ensuring that standard and correct information is entered is also essential. There is often a trade-off to be made when weighing the value of data collected against the cost of collecting it. With the right hardware and smart software, it is possible for technicians to record data quickly and accurately without adding an unnecessary burden. A well-designed system can greatly reduce the amount of follow-up data entry and provide the quality assurance required.

1.3. Ease of Use

To have an accurate, consistent, and usable system, it is important to limit the amount of time spent entering and updating records. This can be achieved by incorporating automated data collection and validation into maintenance processes. In addition to automated validation, use of handheld devices can decrease entry error and allow for automated capture of many data elements, e.g. date, time, asset, technician, etc. Typically, the manner that maintenance data will be used is not known at the time the system is implemented. Modern software systems can provide an interface that makes data entry easy and accurate and can also store information in a way that facilitates later use by the various groups who need to access the data. These software systems must allow for modification of the metadata frames that then port to all similar assets so the system can be realistic, dynamic and “future-proof”.

1.4. Root Cause Analysis: Down to the Bolt

To truly understand the impact each part has on overall reliability and availability, it is important to distinguish between parts that caused a failure (primary failures), parts that failed as a result of the primary failure (secondary failures), and other parts that need to be repaired/replaced in the process of performing maintenance on parts with primary and secondary failures (ancillary failures). For example, if a power spike from a power supply causes the power supply to fail and also shorts out a circuit board under a console panel, then the power supply is a primary failure, the circuit board is a secondary failure, and the console panel is an ancillary failure. If multiple parts are worked on for the same maintenance action, a “Failed Part” field could be used to identify parts with primary failures and distinguish them from those with secondary or ancillary failures. Additionally, parts are sometimes opportunistically replaced when other maintenance events are underway, thus significantly reducing their replacement time and/or cost compared to their usual replacement time and/or cost.

1.4. Root Cause Analysis: Down to the Bolt (continued)

These opportunistic replacement activities should also be captured. In some cases, the part with a primary failure may not be obvious at the time of the maintenance event. In these cases, returning to the maintenance record after the root cause is discovered will be important to create an accurate and complete assessment of the maintenance event.

1.5. Cost Tracking: Labor and Replacement Parts

While availability and reliability are key metrics in assessing equipment performance, understanding what is driving maintenance costs can be just as valuable. Typically, the parts and personnel costs are stored outside the maintenance system and the relevant information from the maintenance system, including parts replaced and man-hours, is used to calculate the total cost for each maintenance event. This information needs to be holistically integrated with the real-time data via connectors to the enterprise resource planning (ERP) system(s). Only then can visibility from normal operation, including fault and repair, and all of the associated costs be coordinated. When this information is integrated and available to all personnel responsible for asset operation, then root cause analysis and a complete understanding of asset operation costs can be obtained and kept for future use.

1.6. Part Source Identification

For relevant event types, the source of parts should be clearly captured. This includes parts cannibalized from other equipment, purchased outside the main supply system, and acquired by other means, including parts machined on-site. Identifying the source of parts, including those exchanged between equipment, will allow for accurate cost calculations and set the stage for advanced CMMS uses, such as parts and inventory tracking. This can be accomplished through a “Parts Source” field. Integrating this information with real-time data is critical to a complete asset management system for the wind plant.

2. Data Collection System

The first step to information rich decision making is accessible storage of the vast amounts of data generated by each turbine, sub-station, and ancillary equipment (Balance of Plant, or BOP).

2. Data Collection System

(continued)

As with any storage solution, the initial step in the design process is the most important: deciding the type and use of information that needs to be extracted, analyzed, and visualized. Designing a data collection infrastructure with the end use in mind allows for the eventual retrieval, analysis, reporting, and displaying of information in a far more efficient and effective manner.

2.1. Design, Install, Scale, and Keep Evergreen Data Collection Systems

Wind plant operators want tools to drive their decisions with solid data. After determining what systems are most appropriate and the general type of data that should be captured, implementation is the next step. Yet implementation is not a trivial task and requires committed and knowledgeable staff and executives both on the owner and vendor sides. Incomplete and ineffectual implementations result in high-cost systems with few benefits, often requiring replacement or upgrade before any return on investment can be achieved. Additionally, one of the most important aspects of data architecture is that it needs to evolve. Many good systems are eventually tossed aside or misused because they do not evolve and grow as the business changes. For companies that own or operate multiple turbine technologies, the initial design stage also needs to include an assessment of the data available from each technology and a way to map these data points so that equal comparisons can be made.

The design of the data collection and storage systems can be approached from two directions: internal resources and external vendor and system integrator services. Often the use of internal skills and systems facilitates a custom approach that best suits the company and its existing infrastructure. However, realistic assessment of the skills available versus the skills required is an important first step. A hybrid approach of using external contractors to fill any gaps in in-house knowledge is also an effective solution. Once it is established that the skills needed are available, a detailed cost assessment can then be performed.

Collecting data and collecting useful data are not the same, and this distinction is often the defining characteristic of a successful implementation versus an unsuccessful one. Paradoxically, the vast amount of data available can make collecting useful data more challenging. Wind plants produce staggering amounts of data. Estimated annual storage of essential supervisory control and data acquisition (SCADA) data from a plant with 100 modern wind turbines can exceed 150 gigabytes of data annually and this figure increases dramatically if every SCADA tag is stored at the highest possible frequency. Collecting too much or too little data can result in inefficient systems that do not produce the analysis results that are expected.

2.1. Design, Install, Scale, and Keep Evergreen Data Collection Systems

(continued)

Decisions need to be made in advance of data collection to establish the types of analysis needed, thereby ensuring the collection of the data needed to complete the analysis. Architecting the hardware properly at the sites to minimize data issues due to undersized hardware forcing future site upgrades (hardware and software) is key also. Management of the data system is also required during implementation to tune the data streams so that unnecessary data (instrument noise) is not collected. Proper tuning can dramatically reduce disk consumption and future storage requirements. Well-managed data streams also allow rapid retrieval via the real-time data search systems.

While data collection for wind turbines is important to fully understand plant reliability, data must be collected for turbines and other equipment in the Balance of Plant (BOP). Data from meteorological towers, the substation, and the electrical collection system are absolutely necessary to understand the reliability of the turbines and the whole plant. For example, turbine availability can be 100%, but if the substation is down the plant is not producing. Failing to capture such a situation will lead to large blind spots in any reliability analysis.

2.2. Data Collection and Storage

In any data storage scheme, the structure of the whole is as important as the structure of the individual parts. There are two common approaches to wind plant data storage; relational databases and data historians. Relational database (RDB) products offer storage of large data sets useful for non-real-time or instrument/equipment data. RDBs are very effective for storing asset information and other key textual data associated with the wind plant. This type of database is widely used in many implementations throughout many industries. Real-time data historian products are information technology systems that store time series data, allowing the storage of large data streams at high speed while using compression to manage the hard drive storage space needed for these millions of pieces of information. Data historians are commonly found in manufacturing, pharmaceutical, and utility industries including wind.

2.3. Supervisory Control and Data Acquisition (SCADA): Time Series Data

One of two main types of information captured by SCADA is time series data on the turbine, BOP, and environmental conditions. For turbines, this time series data creates the “heartbeat” of the machine. It is collected almost continuously, typically once per second or more often, and is stored in regular intervals at the limit of the instrumentation and the data collection architecture. The various data streams that are captured are sometimes referred to as tags. For those familiar with traditional databases, a tag is like a database field. These data points record the operating conditions of the turbine and its parts, as well as the environmental conditions in which the turbine is operating. Many plants choose to archive their SCADA data in a real-time historian.

A multitude of time series data is available from a wind turbine SCADA system, enabling a great variety of analysis. As an example, the set of tags necessary for basic reliability analysis for a turbine is:

2.3.1. Turbine Status or Operating State

Terminology can vary widely among owner/operators or original equipment manufacturers (OEMs), but some basic examples include: up and running, available but idle, down for repair, curtailed, and manually stopped at the turbine.

This value can be stored as a text field, usually with abbreviated versions of the state descriptions, or as an integer with a given number mapping to a specific description. If this value is stored as an integer, care should be taken so that it is not translated to a real number in an historian or other database. If 1 means “up and generating” and 2 means “down for maintenance”, a value of 1.62 is not very useful.

For turbine status, high-resolution data, data captured very frequently versus less often, is necessary to determine turbine status over the full course of a day, week, month, or year. When turbines are coming online and offline frequently, data that does not show the state changes do not provide enough visibility into the turbine’s true condition. This limitation can be overcome either by collecting this data at a higher frequency or by only capturing this data upon state change. Collecting upon change will yield the best data storage performance with respect to hard drive space consumption and retrieval speed.

2.3.2. Power Generated

Typically stored in MW, the power generated by the turbine is very useful for reporting on turbine production. It can also be a valuable “sanity check” when various data sources are in conflict regarding the turbine’s actual status.

Most SCADA systems offer more than one power metric: turbine, string, or park. It is important to be clear which is being reported. This is managed by careful metadata and taxonomy design.

2.3.3. Wind Speed

Typically, there will be at least two sources of wind speed data: the turbine’s anemometry and the meteorological tower. Both sources can be useful to understand what is really happening at a turbine.

All analyses of a wind plant’s operations need to consider wind speed. Ideally, the actual wind speed, usually measured in meters per second, should be captured. When this data is plotted in a turbine power curve, a highly effective tool for combining wind speed and power output and determining, from the shape of the curve, how a turbine is performing is available to owner/operator and OEM staff.

Beyond those listed above, many of the other turbine, BOP, and environmental tags in the SCADA time series data will be useful at some point for root cause reliability analysis. In particular, tags that are generally useful for root cause analysis include measures of temperature, including ambient air temperature and the temperature of components, measures of other air conditions, including wind speed and direction, air pressure or density, and turbulence, and vibration modes from multiple contact points and rotational speeds of the components in the turbine. Transformer gas and condition monitors are also highly useful for preventing transformer failure as replacement lead times for these components are typically several months to a year.

2.4. SCADA: Alarms

The second type of SCADA data relates to alarms at the turbine. Events, alarms, and faults are collected when they occur, not continuously as with the time series data, but are typically stored as a time series to correlate with the instrument and asset data streams. With this kind of data, information is only stored when something interesting happens, namely events are recorded when the operating or environmental conditions of the turbine and its parts fall outside of specific boundaries. Combined with work orders, alarm information can help provide a complete set of downtime events for each turbine, BOP equipment, and the plant. Ideally, any alarm that requires human intervention will also have a work order associated with it. As an example, turbine alarms should contain the information presented in Table A at a minimum.

Table A

| | |
|---------------------------|--|
| Turbine Identifier | Recording the turbine ID links each alarm with a specific turbine. |
| Event Identifier | Most SCADA systems have a list of a few hundred alarm types. Capturing an identifier for each alarm, then cross-referencing the meaning from a complete list of alarms and their attributes, provides much information about what was going wrong. Attributes can include useful information, such as whether an alarm can be automatically or remotely reset and whether the alarm was triggered automatically or by human intervention. Cross-referencing can be done automatically through the construction of look-up tables and maintaining continuity between alarms, alarm codes, metadata, real-time data, and the overall plant and fleet taxonomy. |
| Alarm Start Date and Time | Date and time when the alarm begins. |
| Alarm End Date and Time | Date and time when the alarm ends. |

2.5. Computerized Maintenance Management Systems: Work Orders

Beyond SCADA storage, many owner/operators have also implemented computerized maintenance management systems (CMMS) for their work orders. A CMMS enables access to work order data for trend analysis, detailed parts tracking, and root cause analysis. A CMMS is a crucial, but frequently overlooked, aspect of the data collection architecture. Paper work orders and technician tribal knowledge are ineffective sources of information about turbine, BOP, and plant performance, especially over the life of the equipment and wind plant. One of the largest analysis challenges facing the wind industry is the current dependence on manual maintenance and repair documentation processes. These are not scalable and deprive owner/operators of the crucial corrective action information that is necessary for root cause analysis. Well-written work orders can provide a goldmine of information for a company while poorly-written work orders can be a waste of valuable technician time.

One of the cardinal rules of a CMMS, or any other data entry system requiring human input, is that it needs to be as painless as possible to do data entry. Automating the data collection with handheld devices, bar coding, and passive identification systems, such as radio frequency identification (RFID) can mean the difference between capturing data or missing critical pieces of the operations and maintenance (O&M) puzzle. The people involved in work order data entry can vary widely, but often include technicians, administrative staff at the plant, and employees in an operations command center (OCC). Other important aspects to keep in mind in designing data entry systems are that optional fields tend to remain blank and “miscellaneous” is a popular choice. Avoiding inaccurate and incomplete tracking and recording can mean the difference between understanding turbine, plant, and fleet performance and multiple root cause unknowns. At a minimum, high-quality work orders for a turbine should contain:

2.5.1. Turbine Identifier

Recording a turbine ID links each maintenance event with a specific turbine. Events that do not tie to a specific turbine can still be captured, but this should be clearly specified. Ideally, there will be options to choose specific BOP equipment in addition to specific turbines.

2.5.2. Event Type

Event type captures, at a high level, what kind of work is being performed, e.g. component failure, preventative maintenance, inspection, etc.

All downtime and maintenance events should be recorded, including inspections and other scheduled maintenance events. Even inspections and scheduled maintenance that is relatively short in duration, relatively infrequent, and/or can occur while the system is running are crucial to understanding the availability, reliability, and financial performance of a system.

2.5.3. Affected Component

Ideally, the affected component would be chosen from a standard breakdown of the turbine, e.g. taxonomy, metadata framework, or equipment breakdown workflow. This value may not be initially known with certainty, so a good CMMS needs to allow for updates, editing, and refinement as more knowledge is gained.

In order to conduct real root-cause analysis, it is also useful to capture a brief description of the failure mechanism and/or the external event that caused the downtime or maintenance, e.g. curtailment, chipped gear tooth, dirty oil, etc.

For relevant event types, the source of parts is also a useful piece of information. This includes parts acquired through non-standard methods, e.g. swapped from another turbine, purchased outside the supply system, machined on site, etc. Identifying the source of parts allows for more accurate cost calculations and will allow more advanced CMMS towards parts and inventory tracking.

2.5.4. Equipment Status

Not all maintenance events will stop a turbine from generating. For example, some inspections are allowed when the turbine is running.

Suggested choices for equipment status include online, offline/fault, planned maintenance, unplanned maintenance, degraded, etc. It is very important to establish categories for up and down time and for operations management to ensure accuracy and consistency amongst the engineering and technician teams.

2.5.5. Event Start Date and Time

Date and time when the status of the turbine changes. Or, if the turbine status does not change due to the start of the event, the date and time the maintenance event begins.

2.5.6. Event End Date and Time

Date and time when the status of the turbine changes. Or, if the turbine status does not change due to the end of the event, the date and time the maintenance event ends.

2.5.7. Downtime

There are many ways to measure downtime. From the event start and end times, the total duration of the downtime or event can be captured. Other useful measures are found in Table B.

Table B

| | |
|-------------------------|--|
| Active Maintenance Time | The total amount of time that maintenance was actively performed on the turbine. |
| Person-Hours | The total number of person-hours required to complete the maintenance action. Note that this may be very different (greater than or less than) the total downtime, and may be greater than the active maintenance time if more than one technician was needed. |
| Waiting Time | Ideally, this can be broken into time spent waiting for a technician to become available, waiting for a part from supply, waiting for a piece of support equipment to become available, or waiting on other administrative or supply delays. |

2.5.8. Description/Comments

Though free-text comments can be difficult to use in an automated way, allowing technicians to capture anything unexpected or unusual about a maintenance event can be quite useful when delving deeply into specific events or types of events. In addition, this field can be helpful to support the collection of additional data while the CMMS is being upgraded to capture it in a more appropriate field.

2.6. Other Systems

In addition to the data that is captured from SCADA and work orders, supplemental turbine and plant information is also needed. ERP systems containing cost and other financial and business information provide the supplemental information needed to support data-based decision making.

Ideally, cost information would include component-level repair costs, component-level replacement costs, consumables costs, e.g. the price of a liter of gearbox oil, costs associated with technician time, and costs associated with overhead, e.g. administrative time if such overhead is linked to maintenance or downtime. Additionally, some plants also look at lost revenue from generation or penalties assessed for not generating.

Information on turbine and BOP configuration is another essential aspect of cross-fleet analysis when performing analysis at system, sub-system, component-group, and component levels, especially across multiple plants or turbine technologies. A hierarchical equipment breakdown flow or structure and the site taxonomy divide the turbines and BOP into their generalized parts in a parent-child relationship that allows sub-parts to be rolled up into sub-assemblies, sub-systems, and systems.

Once a general taxonomy is developed, then each of the turbine technologies or plants can be mapped to it, creating a standard that allows comparison. Also, a detailed description of the equipment (make, model, manufacturer of major components, presence/absence of optional systems such as de-icing equipment or condition monitoring, etc.) is important for comparisons. Lastly, documented system knowledge, such as turbine specifications or sub-station fault trees, can provide the basis for more advanced reliability analysis.

2.7. Data Processes

In the wind industry, many multi-site and OEM companies have implemented operations command centers (OCCs) with real-time operating data flowing from plants to a centralized monitoring and control center. The real-time data is then stored in a single large enterprise-level database covering multiple plants. This approach requires a robust and reliable connection from each turbine and plant to the OCC or reliable data storage at each site so that when connection to the OCC is restored the buffered data is passed to the OCC. An alternative, seen at smaller operators and plants, is where a storage system is implemented on-site and stores a finite time period of SCADA data. Some of these implementations allow for subsets of the data to be sent to a central office for storage and analysis periodically or after events.

Those companies that do store their SCADA data consider it highly proprietary and treat it as intellectual property. This adds a requirement for encryption and security during the transfer of data from the plant and access levels and controls that restrict who can view the stored data. If there is transfer of the data from a plant to an OCC, a hardened high-bandwidth connection is most desirable. This creates a dedicated connection between the wind plant and the OCC, making it a good choice for carrying large amounts of data, as it is both reliable and secure. Once data is stored at the OCC, the use of integrated security protocols can fulfill the needs for controlling access to the data.

After data is stored and accessible to those with the rights to see and use it, data protection becomes a primary task of the data administration staff. Design, implementation, and maintenance of a backup and recovery plan are essential to preventing the loss of data through accident, data corruption, hardware failure, or natural disaster. The plan should include levels of criticality for the data, projected recovery timeframes, scheduling and monitoring of backups, on-going validation testing of the backups, and the media choices on which the backups will be stored.

In addition to backups with the amount of data being stored for each turbine and plant, an archiving strategy is necessary to manage the size of the database and maintain a high-functioning retrieval system. One approach is to archive the raw data but to retain calculated values.

2.7. Data Processes

(continued)

Another approach is to store the data using special compression techniques that reduce the amount of data stored without losing the meaning of the data. Data historians are specially designed with this type of compression in mind. With the cost of storage coming down over the prior decades, archiving strategies should be periodically re-evaluated to ensure that the correct levels of data are available for analysis.

When setting up transfer and storage protocols, the data to be stored must be determined. This concern is especially relevant when looking at the need to summarize the voluminous SCADA time series data. For monthly or yearly performance metrics balanced against the detail needed for root cause analysis, real-time data compression algorithms become critical to balance data storage needs against data completeness. Compression means reducing the number of electronic bits that represent a piece of data, thus reducing the number of bits that need to be transferred from the plant or stored. For example, only storing values when they change can save a great deal of space if that data does not change often.

One of the other aspects of data integrity is addressing missing or illogical data, with data validation serving as an essential aspect of any data collection system. When there is only a single piece missing, it will likely have little to no impact on analysis, but when larger amounts of data are missing, perhaps covering hours, the loss may be important. The practice of data editing or filling in the data with realistic values can assist in creating a complete data set. For illogical data, values for a piece of data can be compared to previous values or sets/ranges of acceptable values, allowing an unrealistic value to be identified. Care must be taken with data editing, as it can reduce confidence in the data as a whole. Among other challenges, important signals can be missed if unexpected, but accurate, values are overwritten. Also, filling in unknown values can mask a data communications problem.

2.7. Data Processes

(continued)

For all of these data integrity concerns, their impact can be reduced by implementing good business processes and procedures, where all employees follow the same process when dealing with the data. Whether the employee is at the plant, in the corporate IT department, or in the engineering/analysis group, business processes allow for the same methodology to be implemented and for necessary improvements to be implemented systematically. These remedies should include a standard approach to the use and interpretation of data. This creates an environment where comparisons between turbines and plants can easily be made because the analysis is based on the same assumptions about the data.

2.8. Integrate Data

One of the greatest challenges in using CMMS and SCADA data to perform reliability analysis is in matching work orders, SCADA time series, and SCADA alarm data. This linking of symptom, e.g. high SCADA temperature recordings followed by a gearbox over-temperature alarm, to corrective action, e.g. a work order to replace a lubrication oil pump, allows for the beginning stages of root cause analysis, parts tracking, and trending. An automated method for performing this linking will greatly improve the detail and accuracy of reliability analysis, but it is not an easy process. Challenges in linking data can include conflicts between CMMS and SCADA regarding turbine status, incomplete work orders, and missing SCADA data. Additionally, real situations that are difficult to interpret will appear, such as curtailment, overlapping work orders, and back-to-back alarms. While no systems emerge as the complete solution after a plant or fleet reaches commercial operation date (COD), continuous investment and improvements to the operational and maintenance systems are crucial for assuring long asset life and the highest levels of production output.

3. Analysis

The culmination of the above two sections is analysis. Analysis incorporates the data generated, collected, and made available to improve the understanding of the current reliability and performance of the wind plant and its turbines. A staged approach is required to impact an O&M strategy through improved availability, increased reliability, and reduced O&M costs. First establish baseline performance to understand what the current situation is, then identify performance drivers and determine their root causes, and finally create action plans for addressing those drivers with higher impact.

3.1. Understand Current Performance

Successfully answering questions, such as “What is the current performance?” and “How good is it?”, is the first step to making improvements. This will point toward problematic areas on which to focus. Examples of questions and analysis related to baseline performance include:

3.1.1. What is the Baseline Performance?

- Calculate basic operations and reliability metrics, such as availability, MTBE (mean time between events), mean down-time, and capacity factor for the plant and then each turbine.

3.1.2. How Does the Plant Performance Compare to the OEM or Financial Expectations?

- Identify and graph how a typical turbine spends its time (what percent of the time is it running, idle and available, down for scheduled maintenance, curtailed, etc.).
- Be sure to identify when the turbine state cannot be determined, such as when SCADA communication is lost or the historian briefly stops recording.

3.1.3. Are the Data Aspects of the Operations and Maintenance Processes Well Understood?

- Make and document assumptions about the data being gathered and how it is gathered, stored, and used for analysis. Institutionalize these assumptions so that all departments have the same meaning for particular pieces of data.

3.2. Identify Performance Drivers

Once baseline performance is understood, then performance drivers can be found. Methods for identifying these drivers can include exploring trends, outliers, good performance, and surprising results. Examples of questions that can be answered at this point and their related analyses include:

3.2.1. What is Driving Poor Performance?

- Identify key contributors to low generation, unavailability (downtime), etc. Exploring top contributors is a simple, but very powerful method for identifying areas for improvement.
- Compare multiple metrics, such as event frequency versus event duration or generation versus turbine wind speed. The outliers are especially interesting in these types of graphs.

3.2.2. Where is Performance Roughly the Same? Where is There Great Variability?

- Explore turbine-to-turbine performance and variability in all the basic aspects including availability, MTBE, mean downtime, and capacity factor.
- Explore daily, weekly, monthly, and seasonal trends. Plot graphs of the metrics over time. Look at the whole plant and also look at individual turbines or individual event types, especially those with very high or very low performance.

3.2.3. Where Are the Business Data Processes Different?

- Address any inconsistencies in data processes and assumptions, including determining if there is a valid reason for doing things differently.
- Understand limitations in the data systems, analysis/modeling, and reporting.

3.3. Determine Root Cause

After understanding baseline performance and identifying some of the key performance drivers, then root causes can be identified to solve problems. Examples of questions and analysis that can be addressed at this point include:

3.3.1. Why are Certain Aspects of Operations, e.g. Turbines or Groups of Turbines, Months or Days of the Week, Types of Scheduled Maintenance, Having Such a Negative Impact?

- Investigate de-rates and periods of unexplained performance.
- Interpret unexpected patterns.

3.3.2. What are the Root Causes of the Top Problems?

- After identifying the operational aspects that have the most impact, conduct root cause investigations. Follow through on this activity. Simply identifying potential root causes is not enough. Real fixes should be developed, tested, implemented, and assessed.

References

- [1] V. A. Peters, P. S. Veers, and A. Ogilvie, "Wind Energy Computerized Maintenance Management System (CMMS): Data Collection Recommendations for Reliability Analysis," Sandia, Albuquerque, NM, USA, SAND2009-4184, 2009.
- [2] B. L. McKenney, A. B. Ogilvie, and V. A. Peters, "Using Wind Plant Data to Increase Reliability", Sandia, Albuquerque, NM, USA, SAND2010-8800, 2011.

RP 506 Wind Turbine Key Performance Indicator Data Reporting Procedures

The following recommended practice (RP) is subject to the disclaimer at the front of this manual. It is important that users read the disclaimer before considering adoption of any portion of this recommended practice.

This recommended practice was prepared by a committee of the AWEA Operations and Maintenance (O&M) Committee.

Committee Chair: David Zeglinski, OSIsoft, LLC
Principal Author: Dave Ippolito, Versify Solutions

Purpose and Scope

The scope of “Wind Turbine Key Performance Indicator Data Reporting Procedures” describes best practices in reporting key performance indicators (KPIs) including recommended data granularity, frequency, and methods for capturing and collecting data required to produce recommended KPIs.

Introduction

This document assumes the reader has working knowledge of SCADA, data capture, and data collection and historian technologies. While this document does not recommend specific technologies, it assumes that SCADA data may be captured and collected using some method of historian technology. Also, this document assumes that integrated values for any underlying data point that is captured may be extracted from the data historian at the described levels of frequency.

Presentation of key performance metrics and any technologies associated with data reporting are also beyond the scope of this document, but is recommended that any reporting or presentation tool or application used allow for both high level "dashboard reporting" that may be tailored for senior management as well as the ability to drill down into granular details as needed by engineers, plant managers, and operators.

Procedures (Detailed Descriptions)

Data should be collected from the plant at various levels of granularity and frequencies based on how the data is to be applied in calculating key performance indicators described below. As a best practice, data should be read from a plant's SCADA system and collected in the data historian utilizing industry standard protocols such as OPC or MODBUS. Depending on the KPI, calculations may be completed as the data is read from SCADA, or may occur after integrated data has been collected over a period of time.

Table A lists operational data that must be collected in order to produce key performance indicators described within this document.

Table A

| | | |
|---------------------|---------------|---------------|
| MW | BOP / Turbine | Hour / Minute |
| Turbine Available | BOP / Turbine | Hour / Minute |
| Turbine Online | BOP / Turbine | Hour / Minute |
| Turbine Fault Code | Turbine | Minute |
| Wind Speed | Turbine | Minute |
| Wind Direction | BOP | Minute |
| Curtailement Events | Turbine | Start / Stop |

Key performance metrics may be calculated as data is collected or tabulated periodically as needed. The following describes KPIs that should be collected for turbines and the balance of the plant.

1. Total MWh

Integrated MWh values for the plant and for each turbine describe plant output and are used for other metrics.

2. Available MW

Hourly metric based on each turbine's nameplate capacity and the total amount of time that the turbine is available.

$$\text{Available MW} = \text{Sum}(\text{turbine available} * \text{turbine capacity})$$

3. Availability

Percentage of plant or turbine that is available for given hour.

Availability = Available MW / Nameplate Capacity

4. Potential Energy

Turbine capability based on design curve and meteorological conditions

Potential Energy = Design Curve(wind speed, RH, BP, etc.)

5. Capacity Factor

Percent of plant or turbine capacity that is producing power

Capacity Factor = Total MWh / Nameplate Capacity

6. Curtailment Hours or Minutes

The total number or minutes or fraction of an hour during which there has been a curtailment event

Curtailment Time = Total minutes between curtailment event start and stop

7. Curtailment MWh

Total MWh lost during curtailment events. Note that it may be desirable to track curtailment MWh for different types of curtailment events. Curtailment MWh is estimated using minute level integrated potential energy, the actual MW for each minute of a curtailment event. This is best computed on a minute level basis and totaled for any given hour.

8. Turbine Faults

The number of distinct turbine fault events should be tracked for each turbine, as well as the total number of faults for the balance of the wind farm. A turbine fault event begins when a turbine fault code is recorded and ends when the turbine is reset and the fault status indicates the turbine is back online.

9. Turbine Fault Lost Energy

Lost energy due to turbine faults may be estimated by subtracting actual energy from potential energy during a given fault event. It may be desirable to track lost energy by fault code, category, and plant levels.

RP 507 Wind Turbine Condition Based Maintenance System Open Architecture

The following recommended practice (RP) is subject to the disclaimer at the front of this manual. It is important that users read the disclaimer before considering adoption of any portion of this recommended practice.

This recommended practice was prepared by a committee of the AWEA Operations and Maintenance (O&M) Committee.

Committee Chair: David Zeglinski, OSIsoft, LLC
Principal Author: Kevin Line, Sentient Science

Purpose and Scope

The purpose of this document is to provide a recommended practice for condition based maintenance (CBM) system architecture for the wind plant, including wind turbine generator, balance of plant, and other elements.

Condition based maintenance and condition monitoring has been shown in many industries to reduce the cost of ownership and increase the availability of assets for operations. Aviation and energy have multiple examples of implementing CBM with positive financial and operational results.

The goal of the best practice is to provide a common, scalable, and open architecture to enable interoperability and cooperation for CBM systems. The advantage to this approach is that the wind plant operator and owner will be able to leverage best-in-breed approaches for CBM through the implementation of an open architecture approach. Furthermore, future technology and capability will be easily integrated into the system with little need for reconfiguration or modification.

Introduction

Implementation of a condition monitoring system can take many forms, processes, and approaches. The general diagram of these systems is shown in Figure A. The description of each component is as follows:

- 1. Wind Plant:** The collection of wind turbine generators and balance of plant equipment needed to generate electricity.
- 2. Wind Turbine Generator (WTG):** The electrical and mechanical system for converting wind energy into electrical energy, including tower, foundation, and balance of plant. The control center for the WTG is not included.

Introduction

(continued)

3. Balance of plant (BOP): Remaining hardware in the plant, not including the WTG.

4. Control Sensors & Hardware: The hardware and software system, typically the SCADA system, on the WTG which supports the control and operation.

5. Condition Monitoring & Sensors: Data collection, processing, and sensors for the purposes of assessing the health and remaining life. This equipment is in addition to SCADA hardware.

6. Data Storage: Standards-based storage of health and control data for the purpose of condition monitoring. Stored data can be local, centralized, or both, depending on system architecture.

7. Data Processing: Local or remote health management system processes collected real-time or off-line data either in time or frequency domain. Health metrics and indicators are restored in the database.

8. Maintenance Interface: Alerts, health indicators, and actions are communicated to appropriate stakeholders, ranging from local maintenance management to supply chain and engineering.

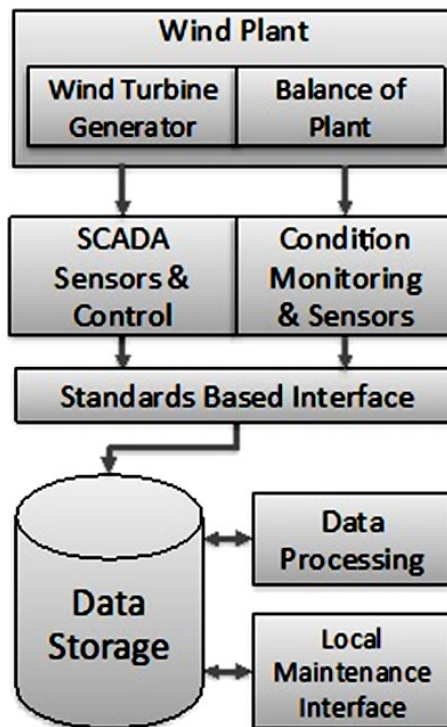

Figure A: Basic CBM System Architecture

CBM Open Architecture

1. CBM System Development

CBM system and data management strategy will be unique for each platform and plant, but follow a similar process. This process is outlined below:

1.1. Identify system failure modes for both WTG and BOP through review of system supplier failure modes and effects (FMEA) analysis, industry data, and interviews with subject matter experts.

1.2. Determine CBM needs and strategy through analysis. Identify high priority components for CBM with careful consideration of failure rate, replacement cost, spare part lead-time, and impact on operations.

1.3. For wind plant, determine required sensors, data collection, processing, and storage equipment to meet strategy.

1.4. Leverage open architecture for CBM system and data management. Through application of open architecture, data collection, management, and processing will have common interfaces to each development and integration. This architecture is created through the open standards approach outlined in the sections below.

1.5. Implement CBM system, through procurement of hardware and software. Install systems and configure per manufacturer instructions.

2. Open Standards: MIMOSA

Once CBM needs have been defined for the system, open standards should be applied. MIMOSA publishes a well-accepted open standard for developing and implementing condition based maintenance systems. Both the OSA-CBM and OSA-EAI are data and communication architectures that define the interfaces between hardware and software. These common interface definitions enable the application of 3rd party capabilities built to the same interface definition and enable data, software, and hardware to remain compatible well into the future, as long as the standards are applied. The complete definitions are found at www.mimosa.org. These open standards are the basis of this recommended practice.

The OSA-CBM architecture is defined by a set of components (physical or virtual components in the system) and workflows (transportation of data from source to user). To achieve this, the architecture is composed of segments and agents. Segments correspond to measurement locations (sensors), and agents (people or systems that analyze data).

2. Open Standards: MIMOSA

(continued)

The workflow for this system is conceptualized in Figure B. From the point of view of the CBM framework, each sensor would be a measurement location. To populate the ports in the module with data acquisition (DA) data events, the sensor interface would be wrapped in an algorithm. These ports and any DA data events they contain would then be available for the rest of the Configuration to use. By using the ports of one or more algorithms as input for other algorithms, the configuration specifies a workflow that processes the data as it flows through. Additional pre-processing for the measurement locations is done at the data manipulation and state determination levels, producing corresponding data events. The end products of this workflow are health assessment, prognostics assessment and advisory generation data events. These high-level data events are created by agents, interfaced by algorithms in the workflow that provide interpretations of the health and prognosis, and provide recommendations on how to deal with them. The CBM process makes data events available to external processes via the interface types in the OSA-CBM specification.

For example, onboard the WTG, sensor data would be stored as data acquisition events. During operation, the bandwidth usage would be minimized by limiting the data events sent to the ground station with monitor ID groups to pass on DA events, filtering out those with number alerts below a certain severity. Additional data may be requested by passing a monitor ID group to a CBM interface requesting a specific subset of data. They would be transferred in a serialized (XML, JSON, YAML, etc.) compressed format.

Another possibility is to move some of the more critical or less processor intensive algorithms in the workflow onboard the WTG. Health and prognostics assessment data events produced by an onboard digital twin would require much less bandwidth than the data acquisition events consumed to produce them. This flexibility allows better balancing of the tradeoff between onboard processing and platform to ground station bandwidth. The network of algorithms and ports produce and consume the data manipulation, state detection, health assessment, prognostics assessment, and advisory generation data events. External applications may then request the data events from specific ports provided by the CBM interface by using monitor ID groups. HA events are used to provide the health level of components; PA events report their remaining useful lives; and AG events give recommendations and optionally requests for work.

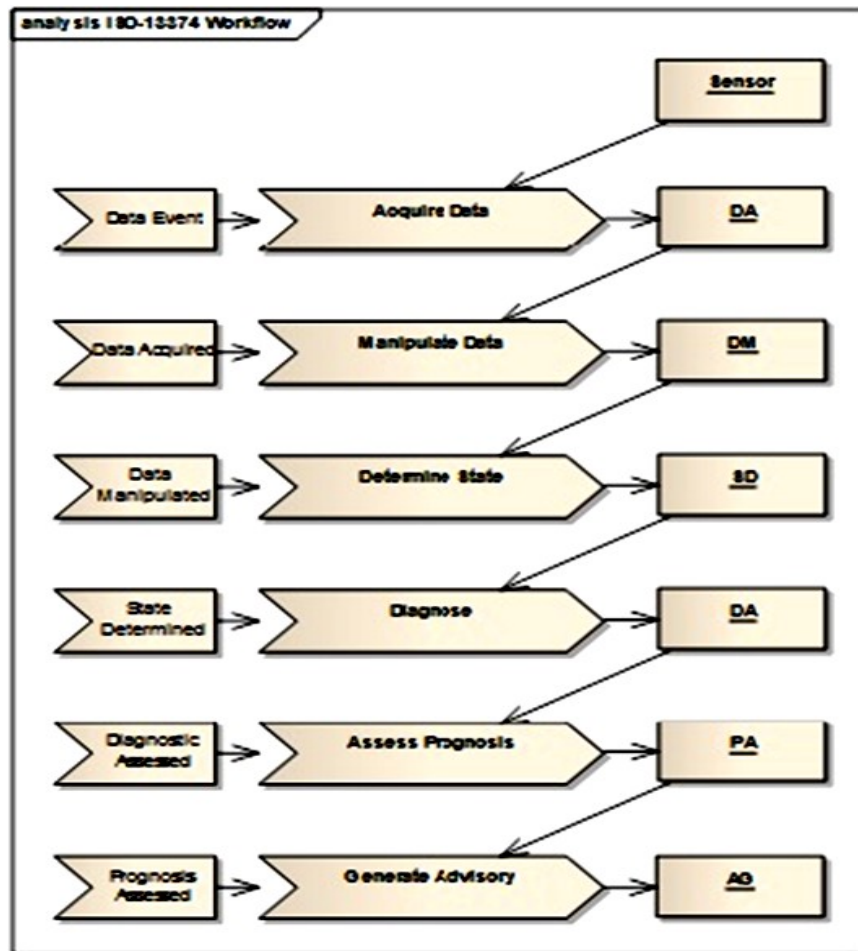

Figure B: OSA-CBM Workflow

3. Interface Definitions

Condition based maintenance system elements will be implemented in the above architecture using the OSA-CBM interface definitions. OSA-CBM interface definitions simplify integrating a wide variety of software and hardware components, as well as developing a framework for these components by specifying a standard architecture and framework for implementing condition based maintenance systems. They describe the functional blocks of CBM systems, as well as the interfaces between those blocks. The standard provides a means to integrate many disparate components, including interfaces with sensors, data acquisition devices, and software algorithms and eases the process by specifying the inputs and outputs between the components. In short, it describes a standardized information delivery system for condition based monitoring. It describes the information that is moved around and how to move it. It also has built in meta-data to describe the processing that is occurring.

3. Interface Definitions

(continued)

OSA-CBM provides an interface standard and defines the interfaces between the functional blocks in a CBM system. Vendors can develop algorithms to fit inside of these blocks, separating the information processing from how it is presented. This separation allows proprietary code and algorithms to be kept hidden inside each of the functional blocks. It also creates a plug-and-play capability where vendors can easily insert updates or roll back to previous versions without affecting other modules or programs relying on the functional blocks. Figure C illustrates an example of proprietary algorithm in one OSA-CBM block.

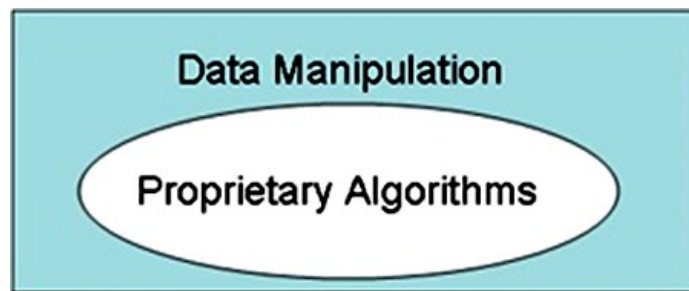

Figure C: Example of Proprietary Algorithm in One OSA-CBM Block

Figure D illustrates the main part of algorithm configuration in OSA-CBM UML specification 3.3.0. Configuration provides information about algorithm input data, descriptions of algorithms used for processing input data, a list of outputs, and various output specifics, such as engineering units and thresholds for alerts.

Writers of algorithms simply need to interact with this interface as it is provided to them in a CBM implementation. This can be accomplished simply in several ways, including inheritance from a base class in object oriented languages. The writer can then override a calling function that accepts an object providing method access to the outputs and any inputs. It is in this way that third-party code compiled into DLLs can be incorporated into the system transparently.

3. Interface Definitions (continued)

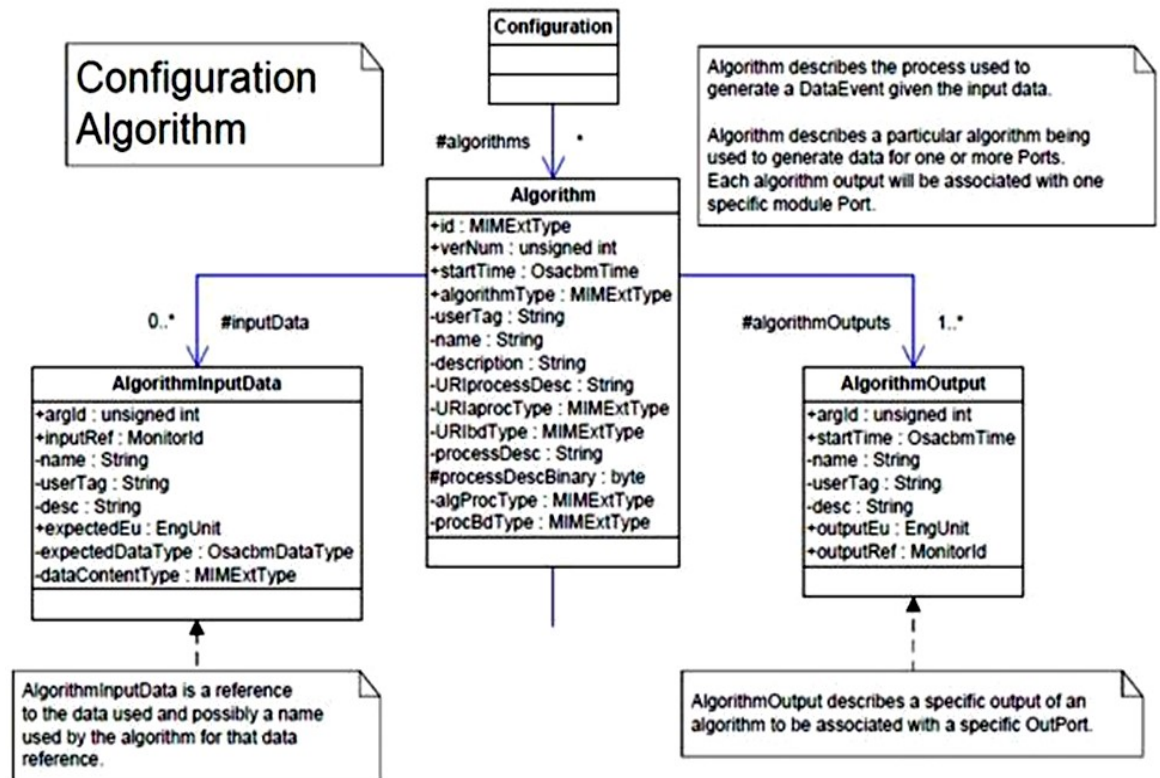

Figure D: Algorithm Configuration in OSA-CBM UML Specification 3.3.0.

Summary

Implementation of the open architectures described herein is a recommended practice by AWEA. These architectures enable widespread and broad cooperation across the industry to enable improved capability and performance of wind turbine system.

References

- [1] *Open System Architecture for Condition-Based Maintenance, OSA-CBM 3.3.0*, 2010.
- [2] *Condition Monitoring and Diagnostics of Machines -- Data Processing, Communication and Presentation -- Part 2: Data Processing*, ISO-13374:2007, 2007

RP 508 Oil Analysis Data Collection and Reporting Procedures

The following recommended practice (RP) is subject to the disclaimer at the front of this manual. It is important that users read the disclaimer before considering adoption of any portion of this recommended practice.

This recommended practice was prepared by a committee of the AWEA Operations and Maintenance (O&M) Committee.

Committee Chair: Bruce Hamilton, Navigant
Principal Author: Allison Toms, Gastops

Purpose and Scope

The scope of “Oil Analysis Data Collection and Reporting Procedures” describes best practices in oil analysis data collection and reporting procedures for optimal information on the condition of the monitored component and proper maintenance actions.

Introduction

Experience has shown that premature gearbox failures are a leading maintenance cost driver of wind turbine operation. Premature gearbox failures reduce turbine availability, result in lost production and downtime, and can add significantly to project lifecycle cost of operation. Oil debris and oil condition monitoring, used in conjunction with prognostics and health management (PHM) monitoring to assess and monitor the health of a wind turbine gearbox, should be part of a comprehensive condition monitoring program.

Oil debris and oil condition analysis techniques offer the potential for detecting early component damage and lubricant degradation, trending the severity of such damage, estimating the time to reach pre-defined damage limits, and providing key information for proactive maintenance decisions, often prior to other monitoring techniques.

Oil debris RP 818 “Wind Turbine On-line Gearbox Debris Condition Monitoring” and oil condition RP 819 “Online Oil Condition Monitoring” monitoring can be accomplished through continuous online sensors or traditional offline “point-in-time” oil and grease RP 815 “Wind Turbine Grease Analysis Test Methods” analysis sampling^[1].

Data Collection

Data collection methods for offline periodic monitoring and online continuous monitoring are summarized below.

1. Offline Periodic Monitoring

Offline periodic “point-in-time” oil, grease, and filter samples, typically taken every six months for wind turbines, are sent to a laboratory for analysis. The laboratory analysis provides details on the oil’s physical properties and contaminants utilizing a wide variety of laboratory tests and instruments. The data generated from all these instruments should be automatically transferred to a laboratory information management system (LIMS) which also contains the sample collection and machinery component information. Manual transcription of data should be avoided.

2. Online Continuous Monitoring

Online sensors provide continuous monitoring for each component being monitored at regular intervals, for example daily. This near real-time data is exported automatically by a variety of methods, such as general packet radio service (GPRS) cellular modem, supervisory control and data acquisition (SCADA), or Ethernet, to a central monitoring location where the data is automatically processed to assess the health of the component.

Data Variability

Oil analysis data is impacted by a wide variety of factors which need to be taken into account for repeatable and reproducible oil analysis data interpretation^[2].

1. Operational and Maintenance Actions

Operational and maintenance actions impact data in predictable ways and these actions should be provided with each sample.

1.1. Operational intensity can impact how quickly a component wears and how rapidly a fault progresses. A relevant indicator of machine usage should be included in any limit and trend calculations.

1.2. Sampling, maintenance, filter, and oil changes are rarely performed at precise intervals. These irregular, opportunistic intervals have a profound effect on measurement data and interfere with trending techniques. Consequently, they need to be taken into account for accurate limit and trend calculations.

2. Sample Collection Techniques

Proper sample collection techniques play a large role in providing representative data. The recommended procedures in RP 102 “Wind Turbine Gearbox Oil Sampling Procedure” and RP 815 “Wind Turbine Grease Analysis Test Methods” should be followed.

3. Laboratories and Test Instruments

Laboratories and test instruments also impact data. This section provides examples of factors that impact oil analysis data interpretation. Online sensors have the benefit of overcoming some of these factors. The following should be adhered to for improved repeatability and reproducibility of data:

3.1. Variations in laboratory analytical instruments impact data reliability. Ideally, trending should only be performed on results obtained from the same make and model of test instrument.

3.2. If samples are analyzed at more than one laboratory, the laboratories should be in a quality assurance program demonstrating a correlation in results obtained from each laboratory and each instrument.

3.3. Laboratories utilized should be certified to ISO 17025^[3] to enhance confidence in the results.

Data Analysis

A significant amount of data is generated by oil analysis monitoring. This data needs to be reduced to useful information regarding component health. Level limits are established to indicate different stages of a fault in progress. Finite limits are typically utilized for parameters, such as allowable water contamination^[4]. However, in addition to level limits, trending the rate of progression of a failure is also very important. A significant change in trend is indicative of the rate of damage progression towards level limits of defined failure stages^[5]. Identifying a failure in the early stages is much more cost effective than allowing it to progress to later failure stages of the machine. Condition monitoring information should clearly and consistently indicate machinery condition from normal through various stages of failure.

Results Reports

Reports for offline periodic monitoring are obtained from oil sample analysis laboratories and reports for online continuous monitoring from automated data processing algorithms.

1. Laboratory Analysis Results

Laboratory analysis results of an oil, grease, or filter sample provide a detailed report of a lubricant's physical properties and quantitative analysis of key contaminants. Figure A is a typical report that provides:

- Customer information
- Component information
- Sample information
- Current sample data
- Two or more prior samples of data for comparison
- New oil data for comparison
- Limit values, if available, for each applicable parameter measured
- Trend values or trend charts, if available, for each applicable parameter measured
- Laboratory comments
- Laboratory recommendations

Limits utilized in the report should state if they were derived based on customers' historical data specific to their components or if they are generic to machine and oil type.

Note that not all parameters measured are applicable to the component. Thus, for non-relevant parameters, level limits and trends are not assigned. Numerous laboratory tests are available. Not all of them provide useful information on component health or can be linked to a failure mode.

1. Laboratory Analysis Results (continued)

Machine Condition **NORMAL**
 Lubricant Condition **MARGINAL**
 Machine Name: WT1 GEARBOX

Analysis Report

| Component Information | Sample Information | Customer Information |
|---|--|----------------------|
| Machine Type: Industrial Gear Lubricant: Machine MFG: Machine MCD: | Sample Size: Unknown Received: 09/15/2016 Report: 09/15/2016 | Wind Farm X |

PROBLEMS
Excessive Particle Count

COMMENTS The particulate contamination exceeds our limits for a gearbox (24/12/12). High particulate contamination will lead to abrasive wear and damage internal components. Reducing particle levels will significantly extend component life.

CUSTOMER NOTES

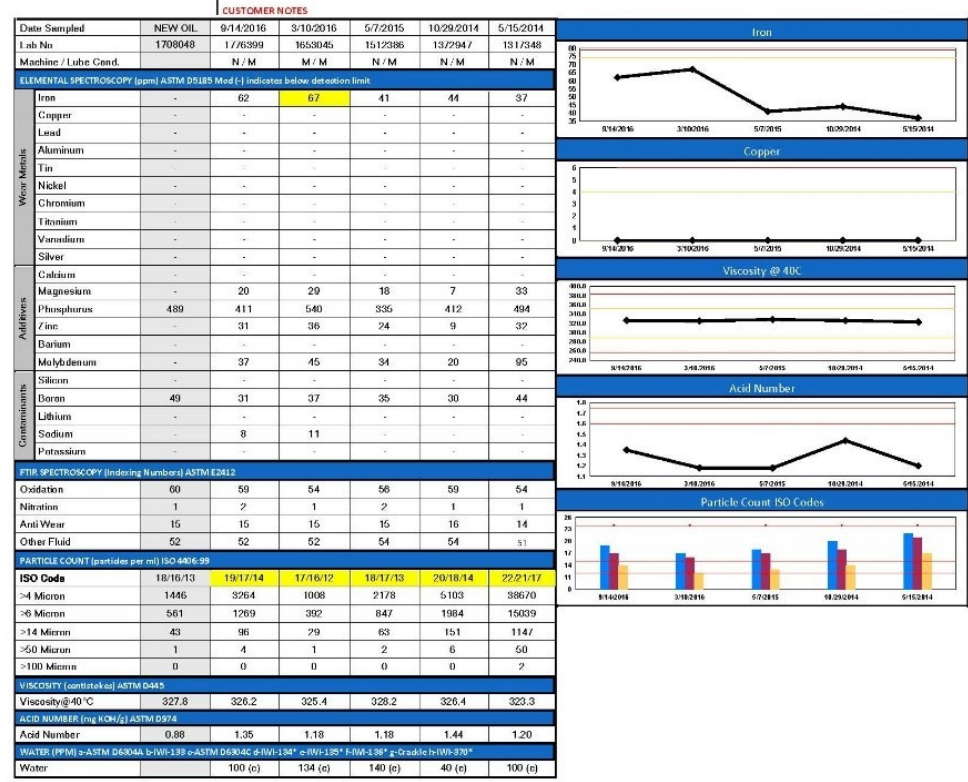

Testing performed by Lab X, an ISO/IEC 17025:2005 accredited laboratory. L.A.3 Accredited Certificate Number xxx. Testing: (*) Not in scope of accreditation. Wind Farm X assumes sole responsibility for the application of and reliance upon results and recommendations reported by Lab X, whose obligation is limited to good faith performance.

Figure A: Laboratory Oil Analysis Report

2. Online Sensor Data

Online sensor data processing provides automated analysis of near real-time results for the parameters they are measuring, such as wear debris. Figure B is a typical daily sensor report for each sensor that indicates the status of each component by means of a trend plot identifying normal or alarm conditions with details on rate of damage progression for the failure mode. Figure C is a typical report that provides the status of all monitored components for the entire wind farm(s). Due to increased time reporting granularity, the real-time online sensor data provides earlier indication of a component's health status, thus allowing operators to identify and take corrective action sooner to improve long-term reliability and reduce lifecycle cost.

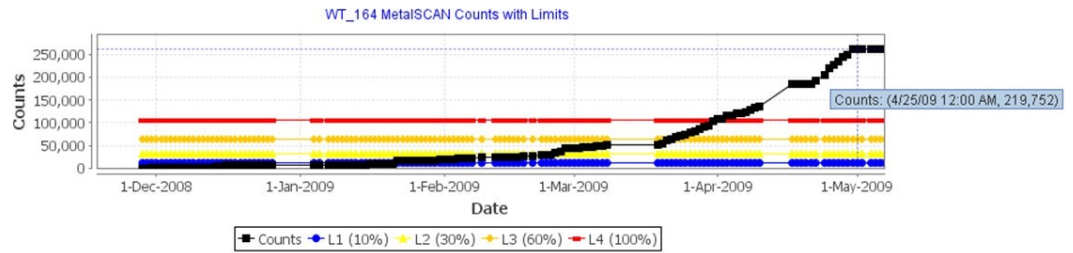

Figure B: Online Wear Debris Sensor Report. Trend Plot with Limits for One Gearbox.

[Equipment Status](#) |
 [MetalSCAN System Status](#) |
 [Equipment Watch List](#) |
 [Fleet Summary](#) |
 [Contact Us](#) |
 [Logout](#)

| Equipment Watch List | | | | | | |
|----------------------|----------|--------------|-----------------|--------|-------------|------------------|
| Equipment ID | Location | Manufacturer | Equipment Model | Counts | Last Count | Equipment Status |
| WT_208 | Farm_14 | MFR_18 | MODEL_30 | 201348 | 28-MAR-2010 | Red |
| WT_56 | Farm_3 | MFR_16 | N/A | 50019 | 09-SEP-2009 | Red |
| WT_109 | Farm_3 | MFR_14 | N/A | 53557 | 09-SEP-2009 | Red |
| WT_42 | Farm_3 | MFR_16 | N/A | 305598 | 09-SEP-2009 | Red |
| WT_134 | Farm_4 | MFR_10 | MODEL_24 | 9460 | 28-MAR-2010 | Yellow |
| WT_151 | Farm_6 | MFR_9 | N/A | 55646 | 26-MAR-2010 | Yellow |
| WT_145 | Farm_6 | MFR_9 | N/A | 42941 | 26-MAR-2010 | Yellow |
| WT_210 | Farm_14 | MFR_18 | MODEL_30 | 17512 | 28-MAR-2010 | Blue |
| WT_221 | Farm_14 | MFR_18 | MODEL_35 | 19618 | 28-MAR-2010 | Blue |
| WT_203 | Farm_14 | MFR_18 | MODEL_30 | 20527 | 28-MAR-2010 | Blue |

Figure C: Online Wear Debris Sensor Report. Wind Farms by Over Limit Status.

Results Integration

Oil and wear debris analysis results should be integrated with results from other sources of information that include condition monitoring results whenever possible, such as vibration and performance condition indicators. Systems can be configured to integrate various types of condition monitoring data, system configuration data, operational data, and maintenance data from different databases to provide enhanced diagnostics and prognostics information.

Summary

Maintaining proper lubrication and early detection of oil wetted component failures is critical to maximize component life and reduce lifecycle costs of a wind turbine. Oil debris and oil condition monitoring are effective techniques to support this goal. Analysis of the significant amount of data for useful information is provided through offline laboratory or online sensor data processing and reporting tools.

References

- [1] *Standard Practice for Inductive Wear Debris Sensors in Gearbox and Drivetrain Applications*, ASTM D7917-14, 2014
- [2] L. A. Toms, and A. M. Toms, *Machinery Oil Analysis -- Methods, Automation and Benefits*, 3rd ed., Park Ridge, IL: STLE, 2008, ch. 9.
- [3] *General Requirements for the Competence of Testing and Calibration Laboratories*, ISO/IEC 17025:2005, 2005.
- [4] *Standard Guide for Statistically Evaluating Measurand Alarm Limits when Using Oil Analysis to Monitor Equipment and Oil for Fitness and Contamination*, ASTM D7720-11, 2017.
- [5] *Standard Guide for Practical Lubricant Condition Data Trend Analysis*, ASTM D7669-15, 2015.

RP 509 NERC GADS Reporting Practices

The following recommended practice (RP) is subject to the disclaimer at the front of this manual. It is important that users read the disclaimer before considering adoption of any portion of this recommended practice.

This recommended practice was prepared by a committee of the AWEA Operations and Maintenance (O&M) Committee.

Committee Chair: Bruce Hamilton, Navigant
Principal Author: Mike Curley, Navigant Consulting, Inc.

Purpose and Scope

The scope of “NERC GADS Reporting Practices” describes best practices in reporting data to the North American Electric Reliability Corporation’s (NERC) Generating Availability Data System (GADS).

Introduction

Established in 1982, NERC GADS is the industry standard for reporting availability performance data. The system has been invaluable to NERC in helping to assess bulk electrical system (BES) reliability issues and trends.

In 2013, GADS became mandatory for conventional generating units 20 MW or larger in size. Before that time, approximately 73% of the conventional generators reported their performance data to GADS. Following mandatory requirements, the number of units reporting to GADS reached 95% of the installed capacity of North America. This did not include any wind or solar generating stations.

Benchmarking is the secondary use of GADS data. NERC and many consultants use GADS data to compare units’ performance. For years, conventional generators have used GADS data to drive continuous improvement programs by comparing their performance to industry performance. GADS allows an “apples-to-apples” comparison of data that is necessary to benchmarking programs.

For details on conventional generating unit data reporting requirements, please visit: www.nerc.com/pa/RAPA/gads/Pages/Data%20Reporting%20Instructions.aspx.

Mandatory Wind Turbine Reporting

For a number of years, GADS collected wind generation on a voluntary basis. The movement to make wind turbine generation mandatory was approved by the NERC committees and the Board of Trustees has approved the following schedule:

- January 1, 2017: The data collection period for voluntary reporting begins.
- January 1, 2018: Mandatory reporting begins for plants with a total installed capacity of 200 MW or larger.
- January 1, 2019: Mandatory reporting begins for plants with a total installed capacity between 100 MW and 199.99 MW.
- January 1, 2020: Mandatory reporting begins for plants with a total installed capacity between 75 MW and 99.99 MW.

The current requirements for collecting data for the GADS wind turbines are listed in a template on the NERC Wind Turbine website at: www.nerc.com/pa/RAPA/gads/Pages/GADS-Wind-DRI.aspx. The instructions for completing the template are in the GADS wind turbine generation data reporting instructions, which are effective January 1, 2017 on the same NERC website.

Many of the outage definitions in the conventional GADS reporting are used with wind. The main differences are conventional GADS uses hours and wind GADS uses wind turbine (WT) hours. “Turbine-Hours” is defined as the time (clock hours) that each WT subgroup is in a forced, maintenance, planned, operating, etc., mode.

Conventional GADS uses consistent definitions and equations developed by the industry (IEEE762) to calculate the key availability metrics. Wind GADS takes these same definitions and equations used by conventional GADS. This data will allow wind generators to compare their performance to others, knowing that when they see a term it has a standard definition and has been calculated in a consistent manner.

Status of Wind GADS as of April 2017

1. Wind data reporting instructions (DRI) changes were approved by NERC's planning committee on September 13, 2016.

2. Revised wind DRI was posted on NERC's website on October 7, 2016. The recent changes included:

- GADS wind page
- Revision history within the document that provides a summary of changes by section.
- Notice to GADS working group (GADSWG), the industry body for monitoring and improving GADS works, and an announcement on the GADS page when available.

3. NERC is contracting with a vendor to create a software program to collect the required wind data as outlined in the recent GADS wind turbine generation DRI. The new software has been reviewed by the GADSWG and is being rolled out.

- Roll out to include industry outreach, training, and registration to access the reporting application.
- Industry outreach by webinars and conference presentations to various wind industry groups.
- Additional outreach via NERC-issued announcements, NERC Regions, and GADSWG. NERC will be presenting three, free GADS wind reporting training sessions at NERC sponsored workshops in 2017 as follows:
 - ◆ Austin, Texas: May 4, 2017
 - ◆ Salt Lake City, Utah: August 10, 2017
 - ◆ Atlanta, Georgia: October 5, 2017

4. NERC has a new dedicated email for wind questions and comments: gadswind@nerc.net.

5. GADS wind reporting application is moving forward and will support data submission, views, and reports/exports.

6. Highlights of recent activities are found in Table A.

Table A: Highlights of Recent Activities

| Purpose | Audience | Delivery method | Timeframe |
|---|---------------------------------------|---|---|
| Testing of Process Training Material | Regional contacts | In-person, instructor-led PowerPoint | Dec. 2016 |
| Testing of Subject Matter Training Material | GADSWG | Webinar-based, instructor-led PowerPoint | Dec./Jan. 2017 |
| Revised Process and Subject Matter Training | Potential GADS Wind users and Regions | In-person and webinar-based instructor-led PowerPoint, including recorded webinar | Feb. and Mar. 2017, plus Oct. and Nov. 2017 |
| Testing of Application Tool Training Material | Regional contacts and GADSWG | Announcement with link to draft training videos on NERC's website with request for feedback | Jan. 2017 |
| Application Tool Training videos | Potential GADS Wind users and Regions | Videos available on NERC's website | Feb. 2017 |
| Train-the-Trainer | Interested organizations | In-person, instructor-led PowerPoint | Q2 or Q3 2017 |

7. IEEE 762 “Definitions for Use in Reporting Electric Generating Unit Reliability, Availability and Productivity” working group is reviewing the definitions and equations for GADS Wind. NERC requested the IEEE committee reform to look at the definitions and equations for the new wind DRI.

8. If you are interested in speaking with the Chair of the NERC GADS Wind Turbine Generation DRI, please contact:

Mr. Fred “Doc” Beasom
Principal PGD Engineer
NextEra Energy Operating Services, LLC
661-821-3490
Fred.Beasom@NextEraEnergy.com

9. If you are interested in speaking with the Chair of the IEEE 762 regarding WT definitions and equations, please contact:

Mr. Alex Schneider
630-613-3395
ASchneider@Quanta-Technology.com

RP 510 HV Substation Data Collection

The following recommended practice (RP) is subject to the disclaimer at the front of this manual. It is important that users read the disclaimer before considering adoption of any portion of this recommended practice.

This recommended practice was prepared by a committee of the AWEA Operations and Maintenance (O&M) Committee.

Committee Chair: Bruce Hamilton, Navigant
Principal Author: Bill Young, Electrical Consultants Inc.

Purpose and Scope

The scope of “HV Substation Data Collection” focuses on wind farm data collection recommendations specific to the high voltage (HV) substation.

Substation Data Reporting Recommendations

1. Identity Data Off-takers

The first step in setting up telemetry for any new site is to identify all of the internal and external data off-takers’ telemetry requirements. This includes what data points are needed, what protocols and circuits are required, and when the data is needed. Often the interconnecting transmission owner and/or the independent system operator (ISO) will have strict data requirements which require certain live supervisory control and data acquisition (SCADA) telemetry to be flowing to their SCADA system before substation energization and plant synchronization. Once this step is completed, the particular telemetry requirements of each identified data off-taker can be examined to determine the required SCADA tags.

2. Common Substation Components and Recommended Data Tags

2.1. Substation Network/IED Connections

Typically, all of the substation relays, control building equipment, and alarms are tied into an remote terminal unit (RTU)/SCADA gateway/data concentrator. Devices can be connected various ways, including using serial cables, Ethernet cables, or fiber cables. Some RTUs include dedicated programmable logic controllers (PLC), Windows or Linux computers with SCADA software, or other proprietary devices.

2.1. Substation Network/IED Connections

(continued)

Some RTUs are very simple and can pull all the various SCADA tags together and serve them up to a master device, while some RTUs can do many extra things, such as math operations, custom logic functions, send emails, etc.

2.2. Transformer(s)

Table A: Typical Transformer Tags

| Tag | Description |
|-----------------------------|---|
| LOR TRIP | Trip status of the lockout relay associated with this transformer |
| LOR Coil Fail | Coil failure monitoring of the lockout relay associated with this transformer |
| Winding Temp | Depending on transformer, there may be multiple temperature alarms available. |
| Oil Level | Low oil level alarm |
| Sudden Pressure | |
| Sudden Oil Flow Trip | |
| 87 TRIP | Transformer differential relay TRIP indication |
| Loss of AC Power | Loss of AC power for fans, etc. |
| Loss of DC Power | Loss of DC control power |

2.3. Breaker(s)

The table below is a set of recommended SCADA tags associated with each high voltage breaker. Other switching devices such as circuit switchers, MODs, etc., will have a smaller subset of these points, potentially only a status feedback.

Table B: Typical Breaker Tags

| Tag | Description |
|--|--|
| VA | A phase voltage of associated BUS |
| VB | B phase voltage of associated BUS |
| VC | C phase voltage of associated BUS |
| IA | A phase current through breaker |
| IB | B phase current through breaker |
| IC | C phase current through breaker |
| P | Real power through breaker |
| Q | Reactive power through breaker |
| Breaker\Circuit Switcher\MOD Status | 52a Status of breaker\circuit switcher\MOD |
| Loss of Close or Trip Voltage Alarm | |
| Loss of Heater Voltage Alarm | |
| Spring Charge Alarm | |
| Trip Coil 1 Fail | Indication that trip coil 1 has failed |
| Trip Coil 2 Fail | Indication that trip coil 2 has failed |
| Trip Indication | Trip indication from associated breaker protective relay |
| Local/Remote Status | Any local/remote switch status |

2.4. Meter(s)

The tags needed from the substation meters can vary depending on site specific PPA, GIA, ISO, and other requirements. Below is an example typical tag list for a substation check meter. Other tags such as detailed harmonic measurements, line and transformer compensation, etc. may and are often included as well depending on the site requirements.

Table C: Typical Meter Tags

| Tag | Description |
|----------------------|---|
| VA | A phase to neutral voltage |
| VB | B phase to neutral voltage |
| VC | C phase to neutral voltage |
| VAB | A phase to B phase line-to-line voltage |
| VBC | B phase to C phase line-to-line voltage |
| VCA | C phase to A phase line-to-line voltage |
| VII AVG | Average line-to-line voltage |
| IA | A phase current |
| IB | B phase current |
| IC | C phase current |
| MW | Megawatts. Typically with the convention that the wind farm producing power is shown as positive. |
| MVAR | Megavars. Typically with the convention that the wind farm producing VARS is shown as positive. |
| PF | Power factor |
| F | System frequency |
| kWH Delivered | A counter of kilowatt hours delivered. Typically with the convention that the wind farm producing power is delivering to the grid. This convention can change site-to-site depending on other requirements. |
| kWH Received | A counter of kilowatt hours received. Typically with the convention that the wind farm consuming power from the grid is received. This convention can change site-to-site depending on other requirements. |
| kVh Delivered | A counter of kilovar hours delivered. Typically with the convention that the wind farm exporting VARS to the grid is delivered. This convention can change site-to-site depending on other requirements. |
| kVH Received | A counter of kilovar hours received. Typically with the convention that the wind farm has received. This convention can change site to site depending on other requirements. |

2.5. Control House/Enclosure

Data from the control enclosure provides some critical alarms, such as indication of loss of AC power, a fire, etc. It is important to properly monitor these alarms so that site operations can respond in a timely manner before larger problems happen.

Table D: Typical Control Enclosure Tags

| Tag | Description |
|---|--|
| Panel or Summary Alarm | Any panel summary or other summary alarms or protective relay alarms that may be available in the control enclosure. Alarms may be brought in individually or grouped. |
| Building Smoke Alarm | |
| Building Hydrogen 1% Alarm | The hydrogen concentration near the batteries has reached 1%. |
| Building Hydrogen 2% Alarm | The hydrogen concentration near the batteries has reached 2%. |
| Building Door Alarm | The door to the control enclosure has been opened. |
| Building Battery Charger Summary Alarm | An alarm associated with the battery charger. |
| Building Battery Charger AC Fail | The AC source to the battery charger has failed. |
| ATS Normal Source Indication | The automatic transfer switch for the control enclosure is using the normal AC source. |
| ATS Emergency Source Indication | The automatic transfer switch for the control enclosure is using the emergency AC source. |
| HVAC Lockout Or Loss of Power | |
| HVAC Low Or High-Temperature Alarm | |

3. Typical Wind Farm SCADA Components that Tie into the Substation

3.1. Turbine Network

The various sensors in each turbine connect to a PLC or some type of computer. These devices are typically connected to network switches that all connect back to a central switch. This allows all of the individual turbines to communicate with the wind farm management system/wind farm power plant controller (WFMS/PPC). The wind turbine network is typically a fiber optic connected Ethernet network running between all of the turbines and the turbine manufacturer's overall power plant control system, which may be located in the substation control building/enclosure, its own enclosure, or in a separate operations building. This network is often isolated from the substation network. Data from the turbine network is often not pulled directly from the Substation SCADA System, but turbine data is exposed via an OLE (object linking and embedding) for process control (OPC) server that can be read into the plant historian.

3.2. Wind Farm Power Plant Controller

The wind farm power plant controller is typically a server or combination of servers that control the wind park. Often these are provided by the turbine manufacturer, but there are also setups with third party controllers as well. The PPC is the eyes into the wind farm system. It allows the operations group to see the status of the park or individual turbines, see the various sensor readings on the turbines, control the turbines, and it also keeps the wind park producing in an acceptable range in terms of both MW and MVAR output as defined by any interconnection agreements, ISO curtailments, etc.

3.2. Wind Farm Power Plant Controller (continued)

Table E shows typical data that the WFMS/PPC may receive from the Substation SCADA System.

Table E: Tags to PPC

| Tag | Description |
|---|--|
| MW Curtailment Set Point | Plant MW curtailment signals from the ISO, market participant, plant owner, or other may come through the substation RTU or be directly entered into the plant turbine SCADA system. |
| Voltage Set Point | If the plant is operating on a voltage schedule, this set point may come through the substation RTU or be directly entered into the plant turbine SCADA system. |
| VAR Set Point | This set point may come through the substation RTU or be directly entered into the plant turbine SCADA system. |
| Substation Analog and Digital Values (Power, Energy, Breaker Status, Alarm Status, etc.) | If the plant SCADA system is acting to aggregate all of the alarms and provide a single interface there may be many points coming from the substation RTU. |

3.2. Wind Farm Power Plant Controller

(continued)

Table F below shows typical data and commands that the PPC may send to the substation RTU.

Table E: Tags from PPC

| Tag | Description |
|---|---|
| Number of turbines online | Number of turbines producing power |
| Number of turbines offline | Number of turbines not producing power |
| Number of turbines state unknown | Number of turbines with loss of communication |
| Number of turbines available | Number of turbines that may or may not be running but are available if there is sufficient wind |
| Gross MW | |
| Gross MVAR | |
| Wind Speed | |
| Temperature | |
| Pressure | |
| Wind Direction | |
| Open/Close Capacitor or Reactor | If there are one or several static reactive devices such as fixed capacitor(s) and reactor(s) there may be one or more tags related to the status and control of these devices. |

3.3. Substation HMI

A human machine interface (HMI) is typically just a computer with software that reads SCADA tags from a data concentrator or RTU and displays the data in a meaningful way on a screen. HMIs can also allow an operator to have remote control of breakers and other devices. HMIs can replace annunciator functionality by including “virtual” annunciators and alarms. HMIs can be used to view historical data. Many modern HMI systems allow both local viewing on a dedicated monitor as well as remote viewing through a web page or other mechanism. An HMI is not a required device and many substations do not have them, but if included they can provide quick visibility of what the site is doing as well as summarize any alarms.

3.4. Interface to POI Utility

The interconnecting utility will often require various SCADA tags from the wind farm and the wind farm owner will want data from the utility, such as revenue meter data. This connection may be done in various ways, such as over optical ground wire (OPGW) as a direct fiber connect between the utility RTU and the wind farm RTU, a dedicated private phone line, point-to-point virtual private network (VPN) between customer and utility, etc. **THIS CONNECTION IS OFTEN REQUIRED TO BE FULLY OPERATIONAL BEFORE PERMISSION TO BACK FEED IS GRANTED!**

Questions to ask about the point of interconnection (POI) utility’s data requirements:

- What SCADA tags do they require?
- What SCADA tags will the site want from them?
- Will they require any control?
- When do they require SCADA to be fully functional?
- What type of SCADA testing do they require?
- What protocol do they wish to use to communicate?
- How do they want to communicate physically (e.g. direct fiber, microwave, leased line, etc.)?
- Do they require any equipment, rack space, or floor space in the control building?

3.5. Interface to ISO

Depending on the location of the wind farm, there may be additional independent system operator (ISO) requirements related to SCADA. For example, wind farms in California will be in CAISO territory and wind farms in Texas in ERCOT territory. CAISO, ERCOT, PJM, SPP, MISO, etc. all have varying telemetry requirements, some much stricter than others and some requiring information to be finalized many months ahead of when a new plant will energize. It is very important to understand early on what ISO requirements may be applicable on any given project. ISOs have various SCADA connection requirements as it pertains to the method, protocol, required security and segregation, etc. ISOs take their data very seriously. For example, in some cases a wind farm can be shut down if all of the required meteorological data is not being properly transmitted to the ISO.

Questions to ask about independent system operator's (ISO) data requirements:

- What SCADA tags do they require?
- What SCADA tags will we want from them?
- Will they be issuing any curtailment signals?
- When do they require SCADA to be fully functional?
- What type of SCADA testing do they require?
- What protocol do they wish to use to communicate?
- How do they want to communicate physically (e.g. direct fiber, microwave, leased line, etc.)?
- Do they require any equipment, rack space, or floor space in the control building?

3.6. Interface to Owner

Typically the owner will have some type of external data connection to the plant. This is commonly a dedicated T1/MPLS or other circuits. Often there will be a router and a firewall device between the substation network and the outside world. The firewall helps secure the substation network and meet NERC requirements.

3.6. Interface to Owner

(continued)

Questions to ask about owner SCADA data requirements for the substation:

- What SCADA tags do you require?
- Do you require remote breaker control?
- What type of SCADA testing do you require?
- What protocol do you wish to use?
- How do they want to communicate physically (e.g. direct fiber, microwave, leased line, etc.)?
- What additional floor space will you need for IT or telecom equipment?
- How often is this data needed?
- How will this data be used?
- How will critical alarms be separated from non-critical alarms?

Conclusion

The SCADA tags listed throughout this recommended practice give a good overview of the tags needed to effectively monitor a high voltage substation, as well as some of the common tags needed for the various data off-takers that typically connect to the substation. It is important to review the particular requirements on a site-by-site basis as there are many factors that can play into the different data requirements. What makes sense for one site does not always fit for another.

Chapter 6 Balance of Plant



Operations and Maintenance
Recommended Practices

version 2013

RP 601 Wind Energy Power Plant Collector System Maintenance

The following recommended practice (RP) is subject to the disclaimer at the front of this manual. It is important that users read the disclaimer before considering adoption of any portion of this recommended practice.

This recommended practice was prepared by a committee of the AWEA Operations and Maintenance (O&M) Committee.

Principal Authors:

Rick Johnson, Windemuller
Krys Rootham, Edison Mission
Samuel Moser, Stantec Consulting Services
Tim Bailey, Stantec Consulting Services
Kevin Alewine, Shermco
Grayling Vandervelde, Duke Energy
Michell Rodriguez-Pico, Oklahoma Gas & Electric
Jomaa Ben-hassine, RES Americas
Paul Idziak, Shermco

Committee Chair: Ben Lanz, IMCORP

Purpose and Scope

The scope of “Wind Energy Power Plant Collector System Maintenance” addresses maintenance of a wind farm “balance of plant” collector system. The scope of this document includes electrical collection system components which are recommended for periodic testing or maintenance. The electrical collection system includes systems starting from the exit of the substation and ending at the turbine connection terminals. This document is not intended to be an all-inclusive how-to manual, but to provide general guidance to sound maintenance practices and references to applicable industry standards.

Introduction

Electrical power equipment and systems testing should be performed as specified by manufacturer’s standards from organizations such as IEEE, IEC, ICEA or NFPA 70B. A summary of some of the applicable standards can be found in NETA standards. In most cases, the testing organization should be an independent, third party entity which can function as an unbiased testing authority and is professionally independent of the manufacturers, suppliers, and installers of equipment or systems being evaluated. The organization and its technicians should be regularly engaged in the testing of electrical equipment devices, installations, and systems. An example of one such organization which has an accreditation program is the InterNational Electrical Testing Association (NETA).

Introduction

(continued)

The testing organization should submit appropriate documentation to demonstrate that it satisfactorily complies with these requirements. The testing organization should provide the following:

- All field technical services, tooling, equipment, instrumentation, and technical supervision to perform such tests and inspections
- Specific power requirements for test equipment
- Notification to the owner's representative prior to commencement of any testing
- A timely notification of any system, material, or workmanship that is found deficient based on the results of the acceptance tests
- A written record of all tests and a final report

Safety and precautions practices should be in accordance with NFPA 70E and other applicable standards including IEEE standards.

Collector System Maintenance

1. Collector Grid Configuration

The influence of the collector system voltage, reactive power flow, and harmonics of the collector system can impact the performance, losses, and life of the equipment. Periodically, it is recommended that the collector system operation be evaluated considering transformer tap settings, voltage set points, reactive power set points, wind turbine generator operational conditions, and overall losses. Harmonic monitoring can be installed to determine conditions where the system can be contributing higher than normal harmonic currents. Overall, the collector system operation can be optimized to minimize I²R losses and evaluated for conditions that may reduce the life of the system.

2. Grounding Grid

The purpose of a ground grid at a wind plant is to ensure the safety of personnel and property. During the commissioning process, the ground path impedance should be minimized, verified, and documented according to ASTM G57-95a and IEEE 81. Measurement of the ground resistance and the potential gradients on the surface of the earth as a result of potential ground currents are necessary for:

- Verifying the adequacy and detecting changes to the grounding system
- Detecting potential hazardous step and touch voltages
- Measuring ground potential rise (GPR) to determine adequacy for protection and communication circuits

2. Grounding Grid

(continued)

Ground grid documentation should be readily available. If changes or repairs to the power system are made, operators should consider testing the associated ground grid to ensure that the alterations have not impacted its effectiveness. Frequent and/or extensive damage to turbine blades or other turbine equipment from lightning damage may indicate a potential issue with the grounding grid system.

3. Circuit Breakers and Switchgear

The power circuit breakers used with the pad mount transformers are used to protect the low voltage (LV) power cable and the equipment within the base of the wind turbine generator. These circuit breakers are typically between 400-2000 volts. The project preventative maintenance program should include these basic items to properly sustain the project. The following list of components should be inspected:

- Thermal Imaging: Verify all terminal connections under high level of generation.
- Housing/Frame: Verify the integrity of the breaker housing.
- Operating Mechanism: Check the physical operation by opening and closing the contacts.
- Trip Unit: Verify the trip unit settings with manufacture testing techniques.
- Terminals: Verify the line and load terminals for obvious visual degradation. Check the torque of the cable and bus terminations.

3.1. Inspection and Testing Frequencies

Switchgear circuit breakers and cubicles should be mechanically inspected and electrically tested at the following intervals or events, and/or following manufacturers recommendations:

- Periodically, at two to three year intervals
- Before placing new or modified breakers into service
- Before energizing breakers that have been out-of-service for over 12 months
- After an interruption of electrical short circuits other than a ground fault in a resistance grounded system
- After 1,000 close-open operations (or fewer, depending on manufacturer's recommendations) following the last inspection

3.2. Cubicle Inspection

During the cubicle inspection process, the following items should be completed:

- Examine the bottom of the cubicle for parts that may have fallen from the breaker. The bottom of each cubicle should be maintained clean and free of any foreign objects to facilitate the detection of fallen parts.
- Verify that the mechanical safety interlocks and stops are intact.
- Check that the cubicle heaters, where applicable, are functioning properly.
- Verify that the rack-in mechanism is aligned correctly.
- Lubricate racking mechanism (jacking screws and bearings) according to station experience or manufacturers recommendations. Check brush length of associated motor when applicable.
- Perform an overall inspection looking for loose wiring or components and anomalies. Complete repairs as required.
- Verify that the shutter mechanism functions properly.
- The primary disconnects should be inspected for signs of over-heating, cracked insulation, cleanliness, and misalignment.

NOTE: Normally, the bus side will be energized; hence, the proper safety measures must be followed.

When the foregoing inspection process is satisfactory to the participating electrician, an adhesive label should be attached to the front of the breaker that indicates the date of inspection and the name of the responsible person.

4. Pad Mount and Grounding Transformers

The pad mount and grounding transformer are typically tested over multiple stages during the commissioning process. The first phase is within the transformer manufacturer's facility prior to shipment. Generally, a prototype is constructed and rigorous acceptance testing is performed on the prototype unit to ensure operating compliance. Tests will vary depending on the manufacturer and specifications from the engineer (based on IEEE/ANSI guidelines). Successive tests are performed on the production units depending on the specifications.

4.1. Electrical Tests

Upon arriving at the site, the transformers are inspected for physical damage. After inspection, the transformers are transported to their final resting place. Prior to connecting any external cable including the MV cables, secondary cables, and ground grid, the transformer should be tested. The recommended tests typically consist of the following:

4.1.1. Transformer Turns Ratio Test (TTR) On All Transformer Tap Positions, If Taps Are Present

The TTR is performed to ensure that the turns ratio of the transformer is correct by verifying that none of the transformer windings are shorted. Generally, values should not exceed 0.5% as compared to the calculated value or the adjacent coils.

4.1.2. Winding Resistance Test (WTR)

- Primary winding to ground
- Primary winding to secondary winding
- Secondary winding to ground

4.1.3. Insulation Resistance Test

The insulation resistance test is important for determining the condition of the transformer insulation. Resistance measurements are made between each set of windings and ground, recording the readings at 30 seconds, 1 minute, and every minute afterwards for 10 minutes. The dielectric absorption rate (DAR) is the ratio of the 60 second resistance value to the 30 second resistance value. DAR readings below 1.25 indicate cause for investigation or repair of the transformer. The polarization index (PI) is the ratio of the 10 minute resistance value to the 1 minute resistance value. A PI value of less than 1 indicates possible deterioration and that the transformer is in need of repair.

4.1.4. Thermal Imaging

For oil filled transformers, use a thermal imager to look at medium and low voltage external bushings, connections, cool fins, and the surfaces of critical transformers.

4.2. Non-electrical Testing

4.2.1. Dissolved Gas Analysis for Transformer Oil

The identity of gases generated in a transformer is useful information in a preventative maintenance program. Gases are created when the insulating mineral oil is subjected to any of the following electrical conditions: corona discharge, overheating, or arcing. The gases result from the breakdown of mineral oil and conductor insulation materials. If gassing is extensive, the upper gas space may contain a lower explosive limit (LEL). Following are gases commonly found in a mineral oil DGA analysis:

Table A

| Generated Gas | PPM in Oil (DGA) That Results in Gas Space LEL |
|--|--|
| Hydrogen (H ₂) | 2,232 ppm |
| Carbon Monoxide (CO) | 16,625 ppm |
| Methane (CH ₄) | 23,214 ppm |
| Ethane (C ₂ H ₆) | 77,700 ppm |
| Ethylene (C ₂ H ₄) | 54,560 ppm |
| Acetylene (C ₂ H ₂) | 30,500 ppm |
| Carbon Dioxide (CO ₂) | N/A |

NOTE: N₂ and O₂ are also present in the oil, but are the result of tank air leaks and the oil's exposure to atmosphere.

To be a potential explosion hazard:

- The combustible gas concentration in the gas space must exceed the lower explosive limit.
- O₂ must be present in the gas space in sufficient concentration.
- An ignition source must be introduced.

4.3. Normal Operations

Routine transformer operations, even if greater than LEL percentage, do not present a personnel hazard. The following evolutions can be safely performed on a transformer with a combustible gas concentration above LEL.

- Oil sampling
- 34 kV disconnect switching operations
- Thermography and internal cabinet inspections
- Voltage measurements
- Medium voltage (MV) & LV elbow and cable terminating
- Insulation resistance testing of windings
- Bayonet fuse replacement/inspection
- Crane and rigging of pad mount transformer (PMT) for movement

4.4. Purge Guideline

The following procedure is applicable if a transformer's upper gas space will be opened or exposed for maintenance or inspection. If hot work is to be performed in any transformer compartment or on transformer components, a purge procedure must be completed. GSUs with an expansion tank (vice N₂ blanket) will not have a gas space in the main tank, but could have accumulated gases in the expansion tank. Precautions should be observed if performing work on the expansion tank.

SAFETY NOTE: Explosive gases purged from a transformer gas space may be ignited if they settle or collect in a closed cabinet or stagnant compartment. Keep access doors open and ensure adequate ventilation.

SAFETY NOTE: In addition to the explosion hazard, personnel need to ensure that they recognize the dangers of introducing large amounts of N₂ for purging into a closed or ventilation limited space. Take precautions to maintain a supply of fresh air where personnel are working.

Transformer should be Locked Out-Tagged Out. Grounding may be required depending on system isolation and conditions. Always assume a transformer's upper gas space has a potentially explosive atmosphere that must be diluted and purged. Past DGA oil samples may not exhibit gas-in-oil concentrations high enough to create an LEL, but even a recent DGA sample does not assure that gassing has not occurred in the recent past.

4.4. Purge Guideline

(continued)

NOTE: It is assumed that personnel are using a 4 gas monitor capable of O₂ and LEL measurements, for example a Honeywell Impact Pro Multi-gas Monitor. Check your gas monitor manual to verify samples and that it responds to a variety of combustible gases, including H₂, when developing an LEL percentage.

Smoking, vehicle exhaust, open flame, welding, brazing, etc. in the vicinity of the open gas space is prohibited.

Select two appropriate ports with direct access to the transformer gas space, such as the gas pressure gauge, relief valve fitting, N₂ blanket fitting, gas fill port, access plate, etc. The purge will inject low pressure N₂ into the gas space while venting out the existing gases, thus diluting LEL concentration. Never use a port or access point that is below the transformer oil level, such as the drain valve, top oil temp gauge, or level gauge.

If N₂ purging through a port is impractical, a gas space access plate may be loosened and wedged open to allow free air venting. Check gases released from the tank. Ensure no open flame or ignition source is present until LEL is less than 5%.

Check the transformer nameplate for maximum tank internal pressure, usually 7-10 psi, to avoid damaging the main tank or fins.

Attach a nitrogen gas bottle to one fitting and purge nitrogen into the gas space at low pressure. Verify gas flow into and exiting the transformer. Do not pressurize the tank since most can handle no more than 7-10 psi. If you don't feel gas escaping, STOP.

Monitor the gases escaping the upper gas space. Purge until LEL is less than 5% and decreasing. Stop the purge and let the tank sit for 15 minutes to allow undisturbed gas pockets to re-mix with the N₂ in the upper gas space. Re-initiate the N₂ purge as above. Repeat as necessary until upper gas space is purged of explosive gases and safe to access.

Carefully expose or open the upper gas space to perform hot work. Every couple of hours, if the gas space has not been completely open and ventilated, re-purge to ensure gases-in-oil have not been re-released into the space. Ensure adequate ventilation of fresh air to the work area and cabinet interior.

4.4. Purge Guideline

(continued)

Standard chemical properties for oil include:

- Dielectric strength
- Interfacial tension
- Power factor at 25°C
- Neutralization number
- Water content
- Specific gravity
- Dissolved gas analysis
- PCB

Check list for visual inspection of all components and operation of gauges and controls.

NOTE: It is important to note and record the above results based on the serial number of the transformer, which is typical practice for any third party testing agency. Care should be taken to ensure that accurate readings are obtained and that the results are evaluated by a qualified individual to determine if there are any potential material issues. In the event that the transformer is moved to a different location, it is recommended the above procedure is repeated prior to energization to ensure that damage has not occurred during transport.

4.5. Operational Maintenance

Records of the above commissioning tests should be obtained and used as a baseline. In the case of a transformer failure, these tests should be repeated and documented. To ensure that the performance of the pad mount transformer and grounding transformers continue to meet expectations, visual and infrared camera inspections are recommended on a yearly basis. Oil sampling is recommended on one third of the transformers on a yearly basis. In general, transformers closer to the substation are more critical since disruptions to the collector system closer to the substation put the availability of the wind site at a higher risk.

5. Pad Mount Transformer Foundation

The pad mount transformer are installed on concrete slabs or many times on pre-fabricated fiberglass or fiber-crete box pads. These foundations should be visually inspected for cracking and periodically sealed to mitigate rodent and water access. The sealant should be periodically inspected to minimize water ingress.

6. Secondary Cable Systems

6.1. In many cases, secondary cables are utilized between the turbine controller and the collection system pad mount transformer. The secondary cable insulation rating will range from 600 V to 2000 V depending on the cable design and the wind turbine generator (WTG) type. Typical installations will require multiple conductors per phase. Conductors should be properly labeled with phasing tape or colored cable jackets. After installation and prior to termination to the transformer and controller, a DC insulation resistance test (“megger”) is typically performed. The test voltage is dependent on the insulation value but is usually in the range of 500 V to 2,500 V. The intent of the installation tests are to:

- Ensure that the insulation was not shorted during the installation process. A low voltage insulation resistance measurement of less than 100 Megohm may indicate a problem.
- Verify the cable phasing from one end to the other.

Generally, secondary cable systems are not re-tested as a maintenance practice unless there is reason to suspect a problem. An annual infrared inspection of the terminals is recommended especially on cables deemed critical.

7. Fiber Optic Cable Systems

Upon installation and termination of the fiber optic cables from each WTG, tests are performed to ensure the quality of the fiber optic cable and terminations. Typically one of the following two tests are performed:

- Attenuation (dB) loss testing
- Optical time domain reflectometer (OTDR) testing

Since the network is constantly used for data transmission, it is, in effect, constantly monitored. If there is a network problem, one of the tests above can generally help diagnose the problem. Other than a visual inspection of the connections, periodic maintenance is generally not necessary.

8. Overhead Cable Systems

9. Medium Voltage Cable Systems

Medium voltage cable systems can be found as a part of the collector system and tower cables. During commissioning, field tests range from legacy methods, such as insulation resistance and withstand methods, which are only effective at detecting gross shorts (cable system failures), to sophisticated, predictive partial discharge (PD) tests which detect and locate gross and subtle insulation defects and provide a baseline for future use.

9. Medium Voltage Cable Systems (continued)

The standardized electrical test requirement at the factory for all completed solid dielectric shielded cable insulation system components, including the cable, joints, and terminations, is a partial discharge test performed during a 50 Hz or 60 Hz over voltage. Ideally a partial discharge test comparable with the factory test can be repeated on installed cable systems to assure that they still meet these requirements. If this type of test is not available or deemed impractical for a specific application, a list of alternative tests can be found in the IEEE 400 guide document.

Ideally, during commissioning the following steps are completed on the cable system and a baseline is established:

- Visual inspection for physical damage, such as bends at less-than-minimum bending radius, phase identification, fireproofing, proper shield grounding, cable supports and termination connections, required size and rating per design drawings, and proper separation of power, control, instrumentation, and emergency circuits.
- Conductor phasing test
- Resistance of neutral wires and tapes and conductor resistance/continuity
- Off-line 50 Hz or 60 Hz PD test on each individual span of cable from termination to termination point. This test can provide a profile of the cable system which is comparable to factory standards listed below.
- DC Insulation resistance test (“megger test”) or very low frequency AC test, at the operation voltage or less, on the entire cable system. This test is not intended to detect defects which may fail in the near future but, rather, to detect pre-existing shorts.
- Infrared test of the accessories (terminations and accessible splices) under high current condition.

Table B: Cable System Insulation Test Standards.

| Cable Component | Thresholds |
|-------------------------------|------------------------------------|
| IEEE 48 Terminations | No PD >5pC up to 1.5U _o |
| IEEE 404 Joints | No PD >5pC up to 1.5U _o |
| IEEE 386 Separable Connectors | No PD >3pC up to 1.3U _o |
| ICEA S-94-649 MV Cable | No PD >5pC up to 2U _o * |

*Actually 200 V/mil in factory. Field tests are performed to a maximum voltage value equal to the level of system over voltage protection which is typically 2 times the operating voltage for 35 kV systems (line to ground, 1.0U_o).

9.1. After a Failure

A DC insulation resistance test at operating voltage or less, i.e. 10 kV or 20 kV for a 35 kV system, is recommended after any failure event to confirm the phase of the fault and to confirm that there is not a second fault before re-energizing. Arc reflection fault location technology should be used with a minimum of pulses to determine the location of the fault. To confirm dielectric integrity of the system after repair, an off-line 50 Hz or 60 Hz PD test is recommended.

9.2. Cable Fault Location Equipment/Thumpers

Fault locating methods use fault indicator ("thumpers"), radars, acoustic detectors, or combinations of this equipment. Research indicates that subjecting cable systems to unnecessary surges reduces their remaining life. The industry has developed less evasive fault locating methods that reduce the stress on cable insulation systems. The general approach is to reduce the amount of thumping necessary to locate a fault while simultaneously reducing the voltages required to perform the task.

9.3. Periodic Testing

Comparative infrared testing is recommended annually to check the condition of the mechanical connection of cable system joints and terminations. Off-line 50 Hz or 60Hz PD testing is recommended every 5 years. In many cases operators will focus testing efforts on systems that are most critical (nearest the substation), that have components with a history of failure, or that have components with marginal performance during past tests.

10. Surge Arrestors

Surge arrestors provide over voltage protection for dielectric components. During an over voltage event the surge arrester will become more conductive and shunt the excessive voltage to ground. Arrestors can fail during excessive over voltages or if there is moisture ingress. If arrestors are not functioning properly, the components they are designed to protect will likely fail prematurely.

10. Surge Arrestors

(continued)

During commissioning, surge arrestors on the high and low side transformer and the beginning, mid-point, and end of cable systems typically have the following tests and inspections performed:

- Verify that “station class” arrestors are installed at MV and HV underground to overhead structures.
- Verify nameplate ratings against owner’s specification.
- Insulation resistance test and/or power factor testing should result in similar test results between similar units.
- Test for low impedance path to ground grid with no sharp turns.
- Check the lead length to assure that it is not longer than the manufacturer’s requirement. Long lead lengths cause the device to malfunction. In the absence of the manufacturer’s requirements, lead lengths should be maintained less than 18 inches for MV systems and 3 feet for HV systems.

Dead-front (T-body type) surge arrestors are typically installed at the last WTG in each turbine string for the purpose of protecting collector system equipment from transient overvoltage stresses. To ensure proper functioning, the surge arrestors should be physically and infrared inspected after major events and during periodic inspections.

Surge arrestors are also used at cable system cross-bond points. These arrestors should be inspected and tested according to the manufacturers recommendations. Lead length should be less than 3 feet. Confirm proper lead length and arrestor sizing with your joint manufacturer.

Maintenance of arrestors is recommended. Arrestors should be visually inspected annually, and infrared inspection should be performed every 2 years or after system failures or per the manufacturer’s recommendation.

11. Arc Flash

The arc flash hazard analysis and safety program should be implemented at the early stages of a project. This safety program should be periodically updated, while the arc flash hazard analysis should be reevaluated at a minimum of every 5 years or if the system or connecting electric grid has changed. A proper safety program with equipment should be applied per the NFPA 70E and all federal and local codes.

RP 602 Wind Energy Power Plant Substation and Transmission Line Maintenance

The following recommended practice (RP) is subject to the disclaimer at the front of this manual. It is important that users read the disclaimer before considering adoption of any portion of this recommended practice.

This recommended practice was prepared by a committee of the AWEA Operations and Maintenance (O&M) Committee.

Principal Authors:

Rick Johnson, Windemuller
Krys Rootham, Edison Mission
Samuel Moser, Stantec Consulting
Kevin Alewine, Shermco
Grayling Vandervelde, Duke Energy
Michelle Rodriguez-Pico, Oklahoma Gas & Electric
Jomaa Ben-hassine, RES Americas
Paul Idziak, Shermco
James R. Fairman, S&C Electric, Co

Committee Chair: Ben Lanz, IMCORP

Purpose and Scope

The scope of “Wind Energy Power Plant Substation and Transmission Line Maintenance” addresses the maintenance of wind farm electrical substation components, including area substations, the final connection to the grid, and their interconnecting transmission line. This document is not intended to be an all-inclusive how-to manual but to provide general guidance to sound maintenance practices and references to applicable industry standards.

Introduction

Electrical power equipment and systems testing should be performed as specified by manufacturer’s standards from organizations such as IEEE, IEC, ICEA, or NFPA 70B. A summary of some of the applicable standards can be found in NETA standards. In most cases, the testing organization should be an independent, third party entity which can function as an unbiased testing authority and is professionally independent of the manufacturers, suppliers, and installers of equipment or systems being evaluated. The organization and its technicians should be regularly engaged in the testing of electrical equipment devices, installations, and systems. An example of one such organization which has an accreditation program is the InterNational Electrical Testing Association (NETA).

Introduction

(continued)

The testing organization should submit appropriate documentation to demonstrate that it satisfactorily complies with these requirements. The testing organization should provide the following:

- All field technical services, tooling, equipment, instrumentation, and technical supervision to perform such tests and inspections
- Specific power requirements for test equipment
- Notification to the owner's representative prior to commencement of any testing
- A timely notification of any system, material, or workmanship that is found deficient based on the results of the acceptance tests
- A written record of all tests and a final report

Safety and precaution practices should be in accordance with NFPA 70E and other applicable standards including IEEE standards.

Substation Maintenance

1. Main Power Transformer

The main power transformer should be tested completely before energization. Commissioning documentation should include information included in following testing and energizing procedure.

1.1. Test Oil Dielectric from Bottom Drain Valve

Should be 40 kV or higher.

1.2. Insulation Power Factor and Capacitance to Ground

Make the following test with a suitable power factor bridge. Measure only the power factor and capacitance on winding connections. Be sure to record the temperature of the insulation as accurately as possible. The temperature corrected values should not exceed 0.5%.

- Two winding transformers: HV to GRD with LV winding grounded (H-LG)
- LV-GRD. With HV winding grounded L-HG. HV connected to LV to GRD (HL-G)
- Autotransformers with tertiary winding: HV and LV to GRD with TV grounded (HL-TG)
- Autotransformers without tertiary windings: HV and LV to FRD (HL-G)

1.2. Insulation Power Factor and Capacitance to Ground

(continued)

- Three winding transformers:
 - HV to ground with LV and TV grounded (H-LTG)
 - LV to ground with HV and TV grounded (T-HLG)
 - TV to ground with HV and LV grounded (T-HLG)
 - All windings connected together to ground (HLT-G)

NOTE: Windings may be called by a different name than those given above but the above pattern should be used.

1.3. Check Alarm Circuits

- Fault pressure relay trip settings and outputs
- Pressure relief device
- Top oil temperature gauge indications
- Winding temperature gauge indications
- Gas detector relay

1.4. Test Fan Circuits for Continuity and Voltage

1.5. Check Heat Exchangers

If three phase motors are used and rotated the wrong way, reverse any two main winding wire connections at the motor circuit breaker in the main control cabinet.

NOTE: Copies of every test made on a transformer from time of arrival to present location should be included with the customer's permanent file.

1.6. Check the Following before Energizing

- Check the transformer ground.
- Check the feeder cables bus for proper connection to transformer terminals. There should be no strain on the porcelain insulators.
- Check insulating oil for proper level in all bushings and compartments.
- Check opening and joints for proper sealing.
- Check pressure relief device for proper installation.
- Check the valve from the conservator to the main tank. The valve should be in the open position.
- Check all winding neutrals. They should be properly grounded.
- Check the tightness of the packing nut on the de-energized tap changer handle.

1.6. Check the Following before Energizing

(continued)

- Check radiator valve stem packing nuts and tighten as required. Each valve may require 1/3 to 1/2 turn on the packing nut.
- All radiator valves and/or pump valves should be open and bolted.
- Check lightning arresters for proper installation in accordance with specifications.
- Check transformer finish for scratches. Any damage to the transformer finish during installation should be touched up with paint provided.
- Check relay protection, CTs, and relays for proper connections and operation.
- Fan motor drain holes should be open.
- Check terminal connection in control cabinet for tightness. Check to see that there are no loose connections.
- Check conservator tank breather for proper operation. The dehydrating material should be dark blue.
- All temporary busing safety grounds should be removed.
- The gas detector relay should be bled.
- Heaters in the control cabinets should be energized.
- Check that the shorting straps on winding temperature indicator (WTI) CT terminal block and line drop compensation (LDC) CT terminal block are removed. Check that shorting straps are removed from all other CTs that have loads connected.

WARNING: High voltages may develop across open circuit secondary terminals of CTs when energized. Shorting straps must be in place across the full CT winding for all CTs not connected to low impedance loads to prevent possible personnel hazard and damage to the CT and other equipment. All CT secondary circuits must be grounded, either in the transformer control cabinet or at the load, whether or not the CT is in use.

- All drag hands on alarm gauges and the LTC position indicator should be reset.
- Check lightning arresters on dual voltage units for proper connections.
- All personnel should be clear of the transformer.
- Valve between tank and pressure vacuum regulator should be open.
- Check for approximately 3 lbs pressure on sealed tank units.
- All temporary shipping plugs, etc. should have been removed during installation. Typically these are painted either red or yellow, such as breather plugs in the LTC housing.

1.7. Energizing the Transformer

- Apply full voltage and allow the transformer to operate for at least one hour without load. Listen for unfamiliar noises. Check for excessive vibrations.
- Keep the transformer under observation for the first few hours. Watch gauges to see that specified limits are not exceeded.
- After several days of operation, check for any oil leaks that may have developed after energizing.
- Record the time from first energization.
- Check metering or correct inputs and outputs.
- Check relays for proper inputs and outputs.

1.8. Renewal Parts

Should a transformer be damaged and new parts needed, contact the manufacturer, giving full nameplate information and a description of the part required. If the proper name of the part is in doubt, a simple sketch will expedite prompt shipment to you.

1.9. Maintenance

1.9.1. Periodic Inspection

- External: Check the condition of the paint and finish periodically, especially when the transformer is exposed to inclement atmospheric conditions. If weathering takes place, clean the tank thoroughly and re-paint with an ANSI-approved paint. Wipe off any insulating fluid that might have spilled on surface. Occasionally inspect and tighten all bolted joints and check for leaks.
- Regularly inspect all gauges. The fluid level must remain normal, considering the effects of temperature differences. Refill when samples have been taken. Prolonged periods of zero pressure could indicate a gas leak and should be checked. The fluid temperature should not rise higher than the design value on the name plate after including the effects of ambient temperature. Check blanket nitrogen pressure and bottle pressure.
- Fluid samples should be taken periodically and analyzed as indicated under “Sampling”. It is recommended that you keep a log of the test values to determine when re-conditioning or replenishing service is required.

1.9.2. Sampling Insulating Fluid

NOTE: A sample of fluid should be taken when the unit is warmer than the surrounding air to avoid condensation of moisture on the fluid. Fluid samples must be drawn from the sampling valve located at the bottom of the transformer tank.

- A clean and dry bottle is required. Rinse bottle three times with the fluid being sampled. Make sure fluid being sampled is representative of fluid in the unit.
- Containers used for sampling fluid should be large-mouth glass bottles.
- Test samples should be taken only after the fluid has settled for some time, varying from eight hours for a barrel to several days for a larger transformer. Cold insulating fluid is much slower in settling. Fluid samples for the transformer should be taken from the sampling valve at the bottom of the tank.
- When sampling, a metal or non-rubber hose must be used because oil dissolves the sulfur found in rubber and will prove harmful to the conductor material in the transformer. When drawing samples from the bottom of the transformer or large tank, sufficient fluid must first be drawn off to ensure that the sample will be from the bottom of the tank, and not the fluid stored in the sampling pipe.

1.9.3. Testing Insulating Fluid

For testing the dielectric strength of insulating fluids, follow the technique as specified by the American Society for Testing Material in the method entitled, "*The Standard Method for Testing Electrical Insulating Oils*", D-877.

If, at any time, the dielectric strength of the fluid drops below 26 kV, it should be filtered until it tests at 26 kV or better.

1.9.4. Filtering Insulating Fluid

Mineral fluid can be filtered by means of a filter press. The filter press is effective for the removal of all types of foreign matter, including finely divided carbon and small amounts of moisture. The purifier equipment consists of a specifically proportioned filter press, a positive volume gear pump, driving motor, combined drip pan and mixing tank, necessary piping, valves, strainer, gauges and a drying oven.

The filtering procedure that will ensure the best result is to draw the insulating fluid from one tank, through the filter press, and into a clean tank. Where this method is not practical, a circulation method is recommended. Fluid is drawn from the bottom of a tank, passed through the purifier and discarded at the top of the tank.

Filtration should be continued until the dielectric test of the insulating fluid is 26 kV or better.

1.10. Spare Parts and Services

Keep one set of gaskets for the hand hole and any gasket type bushings used. Other renewal parts may be ordered through the manufacturer. When ordering, give a complete description of the part or problem and give the complete serial number as listed on the nameplate.

1.11. Applicable Standards

- NEMA Publication TR-98 (Latest Issue): “*Guide for Loading Fluid Immersed Power Transformers with 65°C Average Winding Rise*”.
- ANSI Publication C57.93 (Latest Issue): “*Guide for Installation and Maintenance of Fluid Immersed Transformers*”.
- IEEE Publication 64 (Latest Issue): “*Guide for Acceptance and Maintenance of Insulating Fluid in Equipment*”.
- ASTM Specification D-877: “*The Standard Method of Testing Electrical Insulating Fluids*”.

2. Surge Arrestors

Surge arrestors provide over voltage protection for dielectric components. If arrestors are not functioning properly, the components they are designed to protect will likely fail prematurely. During commissioning, surge arrestors on the high and low side transformer and the beginning, midpoint, and end of cable systems typically have the following tests and inspections performed:

- Verify that “station class” arrestors are installed at all overhead-to-underground transitions.
- Verify nameplate ratings against owner’s specification.
- Insulation resistance test and/or power factor testing should result in similar test results between similar units.
- Test for low impedance path to ground grid with no sharp turns.
- Check the lead length to assure that it is not longer than the manufacturer’s requirement. Long lead lengths cause the device to malfunction.

Surge arrestors are also used at cable system cross-bond points. These arrestors should be inspected and tested according to the manufacturer’s recommendations. Lead length should be less than a few feet.

Maintenance of arrestors is recommended. Arrestors should be visually inspected annually. Electrical tests should be performed every 2 years, after system failures, or per the manufacturer’s recommendation.

3. Active and Passive Components

Capacitors, reactors, VAR compensators, and energy storage systems need to be inspected, maintained, and monitored on a frequent basis. Real-time monitoring is recommended for these critical assets. See the Appendix for maintenance intervals.

4. Relays

The following describes a recommended approach to relay testing:

- Perform comprehensive commissioning testing at the time of installation. Use thorough checklists, simulations, laboratory testing, and/or field checks to verify the performance of the protection system, including inputs, outputs, and settings.
- Monitor the relay self-test alarm contact in real time via supervisory control and data acquisition (SCADA) or other monitoring system. If an alarm contact asserts, take immediate steps to repair, replace, or take corrective action for the alarmed relay.

4. Relays (continued)

- Monitor potential relay failures not detected by self-tests. Specifically, these are logic inputs, contact outputs, and analog (voltage and current) inputs. Use continuous check of inputs, e.g. loss-of-potential logic, when available. If a secondary relay system is in place, compare the metering values between the primary and secondary systems.

5. Batteries and Backup Power

5.1. Battery Systems

Each battery system should be maintained and operated as guided by industry practice and manufacturer's recommendations. The following is generally accepted information for the major types of batteries:

5.1.1. Vented Lead

Vented lead-acid cells, known also as wet or flooded cells, make up the majority of DC battery cells in service at sites. The internal lead and lead-sulfate (Pb and PbSO₄) plates are formed with small amounts of antimony, tin, calcium, or selenium alloyed in the plate material to add strength and simplify manufacture. The alloying element has a great effect on the life of the batteries. As water use can be high, electrolyte levels have to be monitored and adjusted as necessary. Equalization charges are necessary for some designs. Fifteen to 20 year life is normal if the cells are well-maintained; however, amp-hour capacity will drop to 80% towards end of life.

- **Vented Lead-acid Antimony:** Vented lead-acid antimony batteries have a nominal specific gravity of 1.210-1.220. Cells have an average float charge of 2.19 ± 0.04 DC volts per cell.
- **Vented Lead-acid Calcium:** Vented lead-acid calcium batteries have a nominal specific gravity of 1.210-1.220. Cells have an average float charge of 2.21 ± 0.04 DC volts per cell.
- **Vented Lead-acid Selenium:** Vented lead-acid selenium batteries have a nominal specific gravity of 1.235-1.250. Cells have an average float charge of 2.20 DC volts per cell, but not more than 2.25 DC volts per cell.

5.1.1. Vented Lead

(continued)

Vented lead-acid Plante cell have lead plates which are grooved to increase their surface area. Special fabrication techniques make this a mechanically and electrically durable battery, but also very costly. Twenty-five year life expectancy is warranted, as is the ability to deliver 100% designed capacity over the full useful life. Watering requirements are minimal and the battery can operate at higher temperatures than non-Plante designs.

- **Vented Lead-acid Plante:** vented lead-acid Plante batteries have a nominal specific gravity of 1.210-1.220. Cells have an average float charge of 2.24 ± 0.01 DC volts per cell at 20-25°C. A voltage of 2.25 DC volts per cell will ensure full capacity at all times with low water loss and will fully recharge the battery after a discharge.

5.1.2. Valve Regulated Lead-acid (Gel Cells)

Valve regulated lead-acid batteries, or gel cells, are often referred to as maintenance free, but this is a misnomer. These batteries remain under constant pressure (1-4 psi), which helps the hydrogen and oxygen gases generated during charging turn back into water. As these cell casings are sealed and non-vented, excessive gas pressure build up is prevented with the installation of a regulating valve. Battery room ventilation requirements are minimal with these sealed cells. These batteries are approximately 60% of the cost of a vented lead-acid cell but can last 20 years if well maintained.

The two most common types are the gel and absorbed glass mat (AGM).

- **Gel Batteries:** gel batteries have a gelling agent (fumed silica) in the electrolyte which immobilizes it in the cell.
- **AGM Batteries:** AGM batteries have a thin fiberglass that holds the electrolyte in place like a sponge. This style battery is preferred over the gel cells.

It is important not to overcharge these batteries. Keeping the temperature of the negative post of the battery within spec will help prevent excessive gassing and thermal runaway. Excessive battery charger AC ripple can damage these cells. While electrolyte levels cannot be monitored as with a vented lead-acid battery, regular testing (impedance/conductance) can detect a dry-out con-

5.1.3. Valve Regulated Lead-acid (VRLA) Batteries

Valve regulated lead-acid (VRLA) batteries have a nominal specific gravity of 1.300. Cells have an average float charge at 2.25-2.30 volts per cell at 20-25°C. VRLA batteries with a nominal specific gravity of 1.250 are to be kept on a float charge of 2.20-2.25 DC volts per cell at 20-25°C. As the room temperature changes, it is necessary to adjust the float voltage proportionally: 2.33-2.36 volts @ 0°C and 2.21-2.24 volts @ 40°C. Increasing the charge voltage to 2.40 volts per cell can reduce charge time of a discharged battery; however, the charge must be monitored and terminated when the charge current decreases to a constant value.

NOTE: Refer to the specific battery manufacturer's recommended float charging voltage for proper float voltage levels.

5.2. Recommended Inspections of Batteries and Backup Power

5.2.1. Physical Inspection

Battery cell casings/jars are to be kept clean and dry. Necessary precautions are to be taken to prevent the intrusion of foreign matter into the cells. Cell caps and flame arrestors are to be in place. All cell connections should be kept tight and free from corrosion.

5.2.2. Room and Cell Temperature

Temperature affects batteries and may alter the set point of the charger voltage. When taking any measurements, always record the temperature of the battery room. As battery cell temperatures drop, so does stored energy capacity. Higher temperatures increase capacity but lower life expectancy. EPRI recommends a battery room temperature range between 60°F (15.5°C) and 90°F (32.2°C), with an average of 77°F (25°C).

5.2.3. Battery Room Ventilation

Battery rooms should be adequately ventilated and exhausted outside the room to an open or outside area. Hydrogen gas concentrations in atmosphere greater than 4% are considered potentially explosive. Room air flow should be sufficient enough to prevent pockets of hydrogen from concentrating near the ceiling.

5.2.3. Battery Room Ventilation

(continued)

NOTE: If the ventilation system is out of service and work needs to be performed in the battery room, the area should be treated as hazardous, both for its oxygen deficiency and for its potentially explosive atmosphere. The room should be ventilated with portable/temporary air movers before proceeding with any work.

5.2.4. Electrolyte Levels

Only battery manufacturer's approved water (distilled or demineralized) shall be used to maintain the electrolyte level in the cell between the marked liquid level lines. Do not overfill the cell. Acid should never be added to or removed from a cell without specific instructions from the manufacturer.

5.2.5. Float Voltage

A battery's float voltage has an effect on the stored amp-hour capacity of the battery. In general, as the float voltage is reduced, so is the stored amp-hour capacity. However, maintaining a higher than suggested float voltage may cause an accelerated decrease of cell electrolyte levels as water is lost.

5.2.6. Inter-cell Connection Resistance

For a battery's inter-cell connection resistance, the measurements for each connection should be obtained and recorded to establish baseline data. A connection should be disassembled, cleaned, reassembled, re-torqued, and re-tested if any connection is greater than 20% above the average resistance or greater than 5 micro-ohms above average (if 5 > 20%).

The re-tested connection measurements should be used in the baseline dataset for future comparison and trending.

During routine testing of inter-cell resistances, an increase of 20% from the recorded baseline readings, for that individual connection, not the battery average, is cause for corrective action.

Sites shall maintain baseline resistance data, as applicable to their battery configuration, for use in determining SAT (less than 20% over baseline) or UNSAT (greater than 20% over baseline) results as measured during routine testing. This individual connection data shall be updated as necessary when connection work changes baseline data.

5.2.6. Inter-cell Connection Resistance

(continued)

NOTE: Refer to IEEE Std. 450, Annex F, “*Methods for Performing Resistance Measurements*”. Refer to IEEE Std. 450, Annex D.2 for discussion of baseline data.

5.2.7. Internal Impedance/Conductance Testing

Internal resistive (conductive) measurements, or BITE (battery impedance test evaluation), can be used to evaluate the electrochemical characteristics of battery cells. The measurements can provide indication of individual cell problems and a degraded ability to provide emergency DC power when required.

Baseline data should be recorded in the first six months, if possible, of placing a battery in service. The record datasheet should note the date of battery (bank or individual) installation and the date when baseline data was recorded. Note that baseline data will vary depending on manufacturer, battery model, amp-hour capacity, and the measuring equipment used.

Testing should be performed under similar conditions, such as cell temperature, float voltage, and charging current. Results will vary with the various models and styles of test equipment, so it is preferable to always use the same equipment.

Significant changes (greater than 100% for impedance, greater than 50% for conductance) from baseline values should be investigated. Over the useful life of a battery, the average cell impedance will rise. Batteries whose impedance values differ from the current testing year bank average by $\pm 20\%$ should be considered for individual load test, equalize charging, or replacement.

NOTE: Refer to IEEE Std. 450, Annex J for further information.

5.2.8. Negative Terminal Temperature (VRLA Batteries Only)

Negative terminal temperature should be less than 3°C (5°F) above room/area ambient temperature. This specification is linked to the requirement that battery charger current and voltage ripple be limited to the values listed below. Ripple above those limits drives internal chemical reactions at the negative post and will release heat into the cell.

5.2.9. Charger AC Ripple Voltage/Current (VRLA Batteries Only)

- Max Voltage ripple: 0.5% of DC float voltage
- Max Current ripple: 5 A per 100 amp-hr rating of battery

6. Generator Lead Line

CAUTION: Extreme caution should be used with inspecting transmission line systems.

6.1. Inspecting the Generator Lead Line.

6.1.1. The interconnect line will be inspected semi-annually for structural integrity and as part of the vegetation management program.

6.1.2. The inspection will be a ground-based inspection conducted by a qualified technician with a check list of items to inspect.

6.1.3. Detailed structural inspections will be conducted on an “as needed” basis.

6.1.4. Personnel assigned to conduct interconnect line inspections will be trained on proper inspection techniques, actions to take when vegetation conditions present an imminent threat of a transmission line outage, the requirements of this procedure, and the requirements for working in the vicinity of energized transmission lines. Documentation of this training should be maintained on-site for a minimum of 5 years.

6.1.5. Any vegetation condition that presents an imminent threat of a transmission line outage will require immediate notification to the owner and an entry recorded in the facility log. An action plan, that may require switching the line out of service, will be implemented until the threat is removed.

6.1.6. Structural components will be visually inspected, utilizing binoculars where needed. If available, during periods of high generation loading, the inspection will include the use of an IR camera to identify high resistance connections. Discrepancies noted during the IR camera survey will be recorded and images will be archived for historical trending.

6.1.7. Visual inspections shall be made to ensure no erosion is present from washouts and/or other means that could result in unstable structural conditions.

6.1.8. Significant discrepancies will be noted with follow up actions itemized. It is recommended that high resolution photographs accompany any discrepancy report.

6.1.9. The inspection results will be reviewed and signed by the owner.

6.1.10. The owner, or designee, is responsible for maintaining the status and remediation of all discrepancies.

6.2. Transmission Vegetation Management Program (TVMP)

6.2.1. The objective of the TVMP is to improve the reliability of the interconnect line by minimizing outages caused by vegetation on or adjacent to the interconnect right of way.

6.2.2. TVMP inspections will be conducted at the same time as the structural inspections.

6.2.3. “Clearance 1” distance shall be a minimum of 50 feet on either side of transmission line centerline. Within those boundaries, all vegetation will be cut to less than 1 foot high. Danger trees beyond 50 feet will be adequately trimmed or removed. Vegetation management need only be conducted when routine inspections identify vegetation that has encroached or violated the “clearance 2” distance.

6.2.4. “Clearance 2” distance shall be a minimum of 25 feet radial clearance between vegetation and all phase conductors under all rated electrical operating conditions. This distance is in excess of the IEEE recommended MAID distance of 4.4 feet, corrected for altitude (ref. IEEE Standard 516-2009, Annex D, Table D.9, where $T = 3.0$).

6.2.5. Inspection results identifying vegetation that has encroached upon the “clearance 2” distance will require vegetation management work to establish all vegetation back to “clearance 1” distances. Vegetation management work should be completed within 60 days of identifying encroachment beyond the “clearance 2” distance. This time requirement is based upon local conditions.

6.2.6. In the event that there are restrictions in attaining the “clearance 1” distance, monthly vegetation management work will be conducted to maintain all vegetation at the “clearance 2” distance. This monthly vegetation management requirement will stay in place until all restrictions are removed and the “clearance 1” distance is re-established.

6.2.7. Vegetation management work will only be conducted by contractors trained and qualified to perform vegetation management work in the vicinity of live transmission lines.

6.2.8. The vegetation management contractor will develop and submit a work plan that:

- Lists all areas noted during the interconnect line inspection where “clearance 2” distance violations were identified
- Specifies the scope of work to be completed including the vegetation management methods to be utilized
- Lists all chemicals planned for use with MSDS sheets attached
- Provides an itemized check list for each area of work with spots for completion signatures by contractor personnel after work quality is accepted by site managers
- Provides documentation that all contractor personnel have been trained on the applicable sections of this procedure and the actions to take upon discovering any vegetation condition that presents an imminent threat of a transmission line outage

The completed work plan will be retained on site for a minimum of 5 years.

6.2.9. Vegetation management work may utilize manual clearing, mechanical clearing, herbicide treatment, or other industry approved methods, as needed, to establish the required distance of “clearance 1”. Address any discrepancies identified during the interconnect line inspection.

6.2.10. Vegetation management work plans will comply with all local, state, and federal requirements.

6.2.11. Vegetation management work plans will require review and approval of the environmental program manager prior to commencement of work.

6.2.12. The owner or designee will ensure compliance with all lease and easement requirements prior to commencing any vegetation management work.

7. Secondary Cable Systems

7.1. In some cases, secondary cables are utilized in substations. The secondary cable insulation rating will range from 600 V to 2000 V depending on the cable design and the wind turbine generator (WTG) type. Typical installations will require multiple conductors per phase. Conductors should be properly labeled with phasing tape or colored cable jackets. After installation and prior to termination to the transformer and controller, a DC insulation resistance test (“megger”) is typically performed. The test voltage is dependent on the insulation value, but is usually in the range of within 500 V to 2,500 V. The intent of the installation tests are to:

- Ensure that the insulation was not shorted during the installation process. A low voltage insulation resistance measurement of less than 100 megohm may indicate a problem.
- Verify the cable phasing from one end to the other.

Generally, secondary cable systems are not re-tested as a maintenance practice unless there is reason to suspect a problem. An annual infrared inspection of the terminals is recommended, especially on cables deemed critical.

8. Fiber Optic Cable Systems

Upon installation and termination of the fiber optic cables from each WTG, tests are performed to ensure the quality of the fiber optic cable and terminations. Typically one of the following two tests are performed: attenuation (dB) loss testing or optical time domain reflectometer (OTDR) testing

Since the network is constantly used for data transmission, it is, in effect, constantly monitored. If there is a network problem, one of the tests above can generally help diagnose the problem. Other than a visual inspection of the connections, periodic maintenance is generally necessary.

9. Medium Voltage Cable Systems

Medium voltage cable systems can be found as a part of the substation electrical system. During commissioning, field tests range from legacy methods, such as insulation resistance and withstand methods, which are only effective at detecting gross shorts (cable system failures), to sophisticated, predictive partial discharge (PD) tests, which detect and locate gross and subtle insulation defects and provide a baseline for future use. The standardized electrical test requirement at the factory for all completed solid dielectric shielded cable insulation system components, including the cable, joints, and terminations, is a partial discharge test performed during a 50 Hz or 60Hz over voltage. Ideally, a partial discharge test comparable with the factory test can be repeated on installed cable systems to ensure that they still meet these requirements. If this type of test is not available or deemed impractical for a specific application, a list of alternative tests can be found in the IEEE 400 guide document.

Ideally, during commissioning the following steps are completed on a cable system and a baseline is established:

- Visual inspection for physical damage, such as bends at less-than-minimum bending radius, phase identification, fireproofing, proper shield grounding, cable supports and termination connections, required size and rating per design drawings, and proper separation of power, control, instrumentation, and emergency circuits.
- Conductor phasing test
- Resistance of neutral wires and tapes and conductor resistance/continuity
- Off-line 50 Hz or 60 Hz PD test on each individual span of cable from termination to termination point. This test can provide a profile of the cable system which is comparable to factory standards listed below.
- DC Insulation resistance test (“megger test”) or very low frequency AC test, at the operation voltage or less, on the entire cable system. This test is not intended to detect defects which may fail in the near future but, rather, to detect pre-existing shorts.
- Infrared test of the accessories (terminations and accessible splices) under high current condition.

9. Medium Voltage Cable Systems (continued)

Table A: Cable System Insulation Test Standards.

| Cable Component | Thresholds |
|-------------------------------|------------------------------------|
| IEEE 48 Terminations | No PD >5pC up to 1.5U _o |
| IEEE 404 Joints | No PD >5pC up to 1.5U _o |
| IEEE 386 Separable Connectors | No PD >3pC up to 1.3U _o |
| ICEA S-94-649 MV Cable | No PD >5pC up to 2U _o * |

*Actually 200 V/mil in factory. Field tests are performed to a maximum voltage value equal to the level of system over voltage protection which is typically 2 times the operating voltage for 35 kV systems (line to ground, 1.0 U_o).

9.1. After a failure

A DC insulation resistance test at an operating voltage or less, i.e. 10 kV or 20 kV for a 35kV system, is recommend after any failure event to confirm the phase of the fault and to confirm that there is not a second fault before re-energizing. Arc reflection fault location technology should be used with a minimum number of pulses to determine the location of the fault. To confirm dielectric integrity of the system after repair, an off-line 50 Hz or 60 Hz PD test is recommended. In some cases, relays can provide some information about the fault.

9.1.1. Cable Fault Location Equipment/Thumpers

Fault locating methods use fault indicators ("thumpers"), radars, acoustic detectors, or combinations of this equipment. Research indicates that subjecting cable systems to unnecessary surges reduces their remaining life. The industry has developed less evasive fault locating methods that reduce the stress on cable insulation systems. The general approach is to reduce the amount of thumping necessary to locate a fault while simultaneously reducing the voltages required to perform the task.

9.2. Periodic Testing

Comparative infrared testing is recommend annually to check the condition of the mechanical connection of cable system joints and terminations. Off-line 50 Hz or 60 Hz PD testing is recommended every 5 years.

Appendix of Maintenance Checklist and Intervals

Table B: Substation Inspection and Maintenance Intervals Based on a 6-year Maintenance Cycle

| Recommended Substation Maintenance Tasks and Intervals | Installation & Commissioning | 5W (Monthly) | 3M (Quarterly) | 1Y (Yearly) | 3 Years | 6 Years | 12 Years | 24 Years |
|---|------------------------------|--------------|----------------|-------------|---------|---------|----------|----------|
| Switchgear | | | | | | | | |
| Inspect, clean, exercise | X | | | X | | | | |
| Grounding Transformers | | | | | | | | |
| Testing should be similar to main power transformers where applicable. | X | | | X | | | | |
| Relay Panels | | | | | | | | |
| Physically inspect lockout relays for mechanical and electrical integrity. | X | | | | X | | | |
| Inspect panel wiring. | X | | | | X | | | |
| Check as-found settings against past known settings. | X | | | | X | | | |
| Perform a physical inspection of relay. | X | | | | X | | | |
| Verify relay settings to RSO/relay database information. | X | | | | X | | | |
| Log any settings changes for testing. | X | | | | X | | | |
| Check and record as-left settings values. | X | | | | X | | | |
| Lamp and megger all CT circuits. | X | | | | X | | | |
| Measure and record all three phase potential and currents inputs. | X | | | | X | | | |
| Perform all control circuit operations including trip checks. | X | | | | X | | | |
| Initiate communications devices. | X | | | | X | | | |
| Check all external trips to the circuit breaker under test. | X | | | | X | | | |
| Check any digital fault recorder points monitoring the relay package. | X | | | | X | | | |
| Verify relay alarms. | X | | | | X | | | |
| Replace DC and low voltage potential circuit fuses on transmission protection circuits. | X | | | | X | | | |
| Check power supply lights, alarms, targets, etc. on relays. Record results. | X | X | | | | | | |

Appendix of Maintenance Checklist and Intervals

Table B: Substation Inspection and Maintenance Intervals Based on a 6-year Maintenance Cycle (continued)

| Recommended Substation Maintenance Tasks and Intervals | Installation & Commissioning | 5W (Monthly) | 3M (Quarterly) | 1Y (Yearly) | 3 Years | 6 Years | 12 Years | 24 Years |
|--|------------------------------|--------------|----------------|-------------|---------|---------|----------|----------|
| Communications Panels | | | | | | | | |
| Inspect panel wiring. | X | | | | | X | | |
| Verify any auto and/or logic. | X | | | | | X | | |
| Perform all control circuit operations including trip checks. | X | | | | | X | | |
| Verify correct operation of check back device or other auto test device. | X | | | | | X | | |
| Verify operation and reset of communications alarms. | X | | | | | X | | |
| Check power supply lights, alarms, status, etc. on comm. equipment where applicable. | X | X | | | | | | |
| Substation Grounding Systems | | | | | | | | |
| Visual inspection (equipment, fence, gates) | X | X | | | | | | |
| Motor Operated Disconnects | | | | | | | | |
| Visual inspection | X | X | | | | | | |
| Thermography | X | | | X | | | | |
| Operate, inspect, lubricate | X | | | | X | | | |
| Contact resistance (ductor) test | X | | | | X | | | |
| Blade and hinge assembly maintenance | X | | | | | | X | |
| Check cabinet heaters. | X | X | | | | | | |

Appendix of Maintenance Checklist and Intervals

Table B: Substation Inspection and Maintenance Intervals Based on a 6-year Maintenance Cycle (continued)

| Recommended Substation Maintenance Tasks and Intervals | Installation & Commissioning | 5W (Monthly) | 3M (Quarterly) | 1Y (Yearly) | 3 Years | 6 Years | 12 Years | 24 Years |
|--|------------------------------|--------------|----------------|-------------|---------|---------|----------|----------|
| Circuit Breakers - SF₆ | | | | | | | | |
| Check indicating lamps (red and green). | X | X | | | | | | |
| Visual inspection | X | X | | | | | | |
| Thermography | X | | | X | | | | |
| Contact resistance (ductor) test | X | | | | X | | | |
| Profile breaker operation. | X | | | | X | | | |
| Power factor test | X | | | | X | | | |
| Travel test | X | | | | X | | | |
| SF ₆ moisture test | X | | | X | | | | |
| Exercise mechanism | X | | | | X | | | |
| Mechanism lubrication and maintenance | X | | | | X | | | |
| Pressurized vessel inspection | X | | | | X | | | |
| Relief valve replacement | X | | | | X | | | |
| Internal inspection | X | | | | | | X | |
| Mechanism refurbishment | | | | | | | | X |
| Check control cabinet heaters. | X | X | | | | | | |
| Check SF ₆ tank heaters. | X | X | | | | | | |
| Check gauges and pressure switches. | X | | | | X | | | |
| Functional alarm test | X | | | | X | | | |
| Substation Bus | | | | | | | | |
| Visual inspection | X | X | | | | | | |
| Thermography | X | | | X | | | | |
| Verify torque of bolted connections. | X | | | | | X | | |
| Substation Foundations | | | | | | | | |
| Visual inspection | X | X | | | | | | |

Appendix of Maintenance Checklist and Intervals

Table B: Substation Inspection and Maintenance Intervals Based on a 6-year Maintenance Cycle (continued)

| Recommended Substation Maintenance Tasks and Intervals | Installation & Commissioning | 5W (Monthly) | 3M (Quarterly) | 1Y (Yearly) | 3 Years | 6 Years | 12 Years | 24 Years |
|---|------------------------------|--------------|----------------|-------------|---------|---------|----------|----------|
| Substation Power Transformers | | | | | | | | |
| Monitor nitrogen pressure (blanket and bottle). | X | X | | | | | | |
| Monitor oil level. | X | X | | | | | | |
| Monitor oil temperatures (top oil and LTC). | X | X | | | | | | |
| Monitor oil flow indicator. | X | X | | | | | | |
| Monitor winding temperature. | X | X | | | | | | |
| Monitor gas accumulator as applicable. | X | X | | | | | | |
| Oil dissolved gas analysis | X | | X | | | | | |
| Oil quality test | X | | X | | | | | |
| Thermography | X | | X | | | | | |
| Power factor test | X | | | | X | | | |
| Low voltage excitation test | X | | | | X | | | |
| Winding resistance (TTR on all taps) | X | | | | X | | | |
| Frequency response analysis | X | | | | X | | | |
| Maintenance inspection | X | | | | X | | | |
| Power wash heat exchangers. | X | | | | X | | | |
| Check cabinet heaters. | X | X | | | | | | |
| Check bushing oil level. | X | X | | | | | | |
| Visual inspection | X | X | | | | | | |
| Functional test, cooling system, alternate lead/lag coolers | X | X | | | | | | |
| Record and reset top oil temperature. | X | X | | | | | | |
| Record and reset top winding temperature range. | X | X | | | | | | |

Appendix of Maintenance Checklist and Intervals

Additional notes to maintenance tasks and intervals: many of these tasks can be minimized or eliminated if real-time monitoring is provided for these assets.

Table B: Substation Inspection and Maintenance Intervals Based on a 6-year Maintenance Cycle (continued)

| Recommended Substation Maintenance Tasks and Intervals | Installation & Commissioning | 5W (Monthly) | 3M (Quarterly) | 1Y (Yearly) | 3 Years | 6 Years | 12 Years | 24 Years |
|--|------------------------------|--------------|----------------|-------------|---------|---------|----------|----------|
| Substation Power Transformers (continued) | | | | | | | | |
| Functional test LTC, run through 'neutral'. | X | X | | | | | | |
| Functional alarm test (aux relay installations) | X | | X | | | | | |
| Functional alarm test (direct wired) | X | | | | X | | | |
| Inspect bushing potential tap. | X | | | | X | | | |
| Check and verify gauges and alarms. | X | | | | X | | | |
| Test sudden pressure relay. | X | | | | X | | | |
| Check automated aux power throw-over switch. | X | | | | X | | | |
| Transformer turns ratio test | X | | | | X | | | |
| Substation Yard | | | | | | | | |
| Visual inspection | X | X | | | | | | |
| Oil/water separator check | X | | | X | | | | |
| Station summarization (cooling) | X | | | X | | | | |
| Station winterization (heating) | X | | | X | | | | |
| Surge Arrestors | | | | | | | | |
| Thermography | X | | | X | | | | |
| Power factor test | X | | | | X | | | |
| Visual inspection | X | X | | | | | | |
| Detailed visual report | X | | | | X | | | |
| MV Cable | | | | | | | | |
| Thermography terminations (high load) | X | | | X | | | | |
| Off-line 50/60 Hz PD test | X | | | | | X | | |
| Visual inspection | X | | | X | | | | |
| LV Cable | | | | | | | | |
| Thermography terminations (high load) | X | | | X | | | | |
| Insulation resistance | X | | | | | | | |

Transmission Line

These tasks should be done at the time of original installation and commissioning and then repeated at 1 year and every 3 years. Thermography should be done quarterly.

Table C: Transmission Line Tasks

| Transmission Pole and Frame Structure Inspections | Installation & Commissioning | 3M (Quarterly) | 1Y (Yearly) | 3 Years | 6 Years | 12 Years | 24 Years |
|--|------------------------------|----------------|-------------|---------|---------|----------|----------|
| Pole identification plates are present and fastened securely to the structure | X | | | | X | X | X |
| Cross arm inspection: rainwater entrapment and moisture damage at connection points and hardware fastening points | X | | | | X | X | X |
| Oil coating inspection. Verify the wood surface is adequately soaked with oil. | X | | | X | X | X | X |
| Frame does not lean or list outside of intended structural design | X | | | X | X | X | X |
| Insulators and transmission cable: strong ties securely fasten cable to insulator glass | X | | | | X | X | X |
| Insulators and transmission cable: insulators are clean with no evidence of arcing | X | | | | X | X | X |
| Insulators and transmission cable: insulators are not cracked | X | | | | X | X | X |
| Insulators and transmission cable: insulators are mounted perpendicular to the frame/structure and cable is not causing undue stress at the attachment point | X | | | | X | X | X |
| Use clamp-on ammeter to identify any AC drain current flowing into the ground circuit. | X | | | | X | X | X |
| Torque Checks and Verification | | | | | | | |
| Re-torque hardware at cross arm joints. | X | | | | X | X | X |
| Re-torque hardware at all jointed connections of the frame. | X | | | | X | X | X |
| Re-torque hardware at all arrestor and insulator attachment points. | X | | | | X | X | X |
| Re-torque hardware at all auxiliary hardware attachment points, i.e. fiber. | X | | | | X | X | X |
| Re-torque hardware at all guy wiring cable crimp hardware. | X | | | | X | X | X |

Transmission Line

These tasks should be done at the time of original installation and commissioning and then repeated at 1 year and every 3 years. Thermography should be done quarterly.

Table C: Transmission Line Tasks (continued)

| Transmission Pole and Frame Structure Inspections | Installation & Commissioning | 3M (Quarterly) | 1Y (Yearly) | 3 Years | 6 Years | 12 Years | 24 Years |
|--|---|-----------------------|--------------------|----------------|----------------|-----------------|-----------------|
| Arrestors | | | | | | | |
| Megger all arrestors on the transmission line circuit. Provide insulation results in final report. | X | | | | X | X | X |
| Inspect ground connection points on arrestors and ensure they are secure. | X | | | | X | X | X |
| Inspect arrestor insulators for signs or arcing or tracking to ground. | X | | | | X | X | X |
| Verify mounting hardware is present. | X | | | | X | X | X |
| Riser Poles | | | | | | | |
| If applicable, inspect all disconnects for proper seating and no evidence of overheating or arcing at seated position. | X | | | | X | X | X |
| Inspect cable for chafe marks at the point where cable exits the riser conduit stubs. | X | | | | X | X | X |
| Verify mounting hardware of conduit riser stubs are all present and secure. | X | | | | X | X | X |
| Verify conduit stubs are sealed. Foam seal if not sealed. | X | | | | X | X | X |
| Torque check cable terminations. | X | | | | X | X | X |
| Inspect cable terminations for signs of overheating, arcing, etc. | X | | | | X | X | X |
| Inspect additionally mounted hardware and reinforcement for signs of looseness. | X | | | | X | X | X |
| T-Line and Fiber Inspections | | | | | | | |
| Inspect all splice points for fraying, slipping, or failure. | X | | | | X | X | X |
| Cable and fiber sag is uniform as compared phase to phase | X | | | | X | X | X |
| Cable and fiber sag is uniform from pole to pole | X | | | | X | X | X |
| Excess fiber coils are secured and not loose at coil locations | X | | | | X | X | X |

Transmission Line

These tasks should be done at the time of original installation and commissioning and then repeated at 1 year and every 3 years. Thermography should be done quarterly.

Table C: Transmission Line Tasks (continued)

| Transmission Pole and Frame Structure Inspections | Installation & Commissioning | 3M (Quarterly) | 1Y (Yearly) | 3 Years | 6 Years | 12 Years | 24 Years |
|---|------------------------------|----------------|-------------|---------|---------|----------|----------|
| Guy Wiring and Structural Re-enforcements | | | | | | | |
| Check tension on all guy wires. Tighten any found to be loose. | X | | | | X | X | X |
| Check that fastening hardware is present and torque marked. | X | | | | X | X | X |
| Check that guy wire marker sleeves are present and in good repair. | X | | | | X | X | X |
| Torque check all fastening hardware. | X | | | | X | X | X |
| Galvanized Frame Structures (If Applicable) | | | | | | | |
| Inspect protective coating/galvanized coating. Look for rust spots. | X | | | | X | X | X |
| Perform inspections at welded joint locations. Look for cracks or rust in welded joints. | X | | | | X | X | X |
| Check that ground connection hardware is present and secure. | X | | | | X | X | X |
| Inspect structure foundations for signs of stress cracking or water intrusion. | X | | | | X | X | X |
| Vegetation Management/Inspection | | | | | | | |
| Fire boundary at the dirt/base exists and is acceptable | X | | | | X | X | X |
| Overhead vegetation is clear of poles, lines, etc. Vegetation boundary allowance, adjacent to cables, incorporates line sag and wind sway | X | | | | X | X | X |

Transmission Line

These tasks should be done at the time of original installation and commissioning and then repeated at 1 year and every 3 years. Thermography should be done quarterly.

Table C: Transmission Line Tasks (continued)

| Transmission Pole and Frame Structure Inspections | Installation & Commissioning | 3M (Quarterly) | 1Y (Yearly) | 3 Years | 6 Years | 12 Years | 24 Years |
|--|------------------------------|----------------|-------------|---------|---------|----------|----------|
| Thermography Inspection | | | | | | | |
| Perform thermographic inspection on all arrestors. | X | X | | | X | X | X |
| Perform thermographic inspection on all T-line Terminations. | X | X | | | X | X | X |
| Perform thermographic inspection on all disconnects & fusing. | X | X | | | X | X | X |
| Perform thermographic inspection on all T-line splices. | X | X | | | X | X | X |
| Perform thermographic inspection on all insulators. | X | X | | | X | X | X |
| Perform thermographic inspection on all ground wiring and jumpers. | X | | | | X | X | X |
| Reporting: General | | | | | | | |
| Prepare report with all deficiencies identified from the above check lists. | X | | | | X | X | X |
| Identify all deficiencies in the summary portion of the maintenance and inspection report. | X | | | | X | X | X |

Transmission Line

These tasks should be done at the time of original installation and commissioning and then repeated at 1 year and every 3 years. Thermography should be done quarterly.

Table C: Transmission Line Tasks (continued)

| Transmission Pole and Frame Structure Inspections | Installation & Commissioning | 3M (Quarterly) | 1Y (Yearly) | 3 Years | 6 Years | 12 Years | 24 Years |
|---|------------------------------|----------------|-------------|---------|---------|----------|----------|
| Reporting: Thermography | | | | | | | |
| Description of equipment and/or object including phase if required | X | X | | | X | X | X |
| Identify criticality of the equipment. | X | X | | | X | X | X |
| Date and time of inspection | X | X | | | X | X | X |
| Visual photograph adjacent to infrared picture | X | X | | | X | X | X |
| Thermograms | X | X | | | X | X | X |
| Ambient temperature, wind speeds, and weather conditions | X | X | | | X | X | X |
| Thermographer name | X | X | | | X | X | X |
| Related operating parameters (equipment loading conditions) | X | X | | | X | X | X |
| Probable cause of failure indicated | X | X | | | X | X | X |
| Recommendation | X | X | | | X | X | X |
| Operational status | X | X | | | X | X | X |
| Temperature rise | X | X | | | X | X | X |
| Temperature reference | X | X | | | X | X | X |
| Related past history of equipment | X | X | | | X | X | X |
| Maximum operating temperature of equipment being thermal imaged (generally available on the name plate) | X | | | | | | |
| All temperatures reported should be on Celsius scale | X | X | | | X | X | X |
| Off-line power frequency PD Test | X | | | | X | | |
| Infrared inspection of terminations and splices (high load) | X | | | | X | | |

Transmission Line

These tasks should be done at the time of original installation and commissioning and then repeated at 1 year and every 3 years. Thermography should be done quarterly.

Table D: Battery Charger Installation

| Battery Charger Installation | Installation & Commissioning | 5W (Monthly) | 3M (Quarterly) | 1Y (Yearly) | 3 Years | 6 Years | 12 Years | 24 Years |
|--------------------------------------|------------------------------|--------------|----------------|-------------|---------|---------|----------|----------|
| Verify charger functions and alarms. | X | X | | | | | | |
| Load test | X | | | X | | | | |
| Battery | | | | | | | | |
| Visual inspection | X | X | | | | | | |
| Battery cell voltage readings | X | | X | | | | | |
| Annual battery inspection | X | | | X | | | | |
| Internal impedance test | X | | | X | | | | |
| Thermography | X | | | X | | | | |

Table E: Static VAR Compensators and Energy Storage

| Battery Charger Installation | Installation & Commissioning | 5W (Monthly) | 3M (Quarterly) | 1Y (Yearly) | 3 Years | 6 Years | 12 Years | 24 Years |
|------------------------------------|------------------------------|--------------|----------------|-------------|---------|---------|----------|----------|
| Inspect, maintain, and monitor. | X | X | X | X | X | X | X | X |
| Thermographic inspections | X | X | X | X | X | X | X | X |
| Verify correct operation. | X | X | X | X | X | X | X | X |
| Capacitor and Reactor Banks | | | | | | | | |
| Inspect, maintain and monitor. | X | X | X | X | X | X | X | X |
| Thermographic inspections | X | X | X | X | X | X | X | X |
| Verify correct operation | X | X | X | X | X | X | X | X |

Chapter 7 End of Warranty



Operations and Maintenance
Recommended Practices

version 2017

RP 701 Wind Project End of Warranty Management and Inspections

The following recommended practice (RP) is subject to the disclaimer at the front of this manual. It is important that users read the disclaimer before considering adoption of any portion of this recommended practice.

This recommended practice was prepared by a committee of the AWEA Operations and Maintenance (O&M) Committee.

Committee Chair: Holly Hughes, Natural Power
Principal Author(s): Eddy Grunenwald, Wanzek Krysz Rootham, Acciona;
Kevin Alewine, Shermco; Chris Henderson, Hendo Consulting
Reviewing Committee: Rich Jigarjian, EDF-R; Bruce Hammett, WECS

Purpose and Scope

The scope of “Wind Project End of Warranty Management and Inspections” discusses preferred methods used to effectively manage construction workmanship, balance of plant (BOP) equipment, wind turbine, and serial defect warranties. This process includes assessing the condition of BOP equipment and wind turbines prior to the expiration of the original equipment manufacturer (OEM) warranty, commonly referred to as end of warranty (EOW) inspections. This document also includes information useful for following the best practice of performing operational audits and quality control of the service provider post-warranty. It is also recommended that the reader consults applicable IEEE, ASTM, IEC, and other industry guidance and standards.

The transition out of the warranty period is a critical milestone in the life of a wind project. Defects or damage due to design, manufacturing, shipping, installation, and maintenance practices are typically covered under warranty agreements and can often be repaired or replaced during this time so that equipment is in the best possible condition exiting the warranty. It is also important to identify and address any sub-performing aspects of the equipment during this period, which can be of particular significance for new models. Scheduled maintenance inspections may not detect component failures and a more thorough inspection with specialized tools is recommended prior to warranty expiration. The priorities in an EOW inspection are to identify component failures, particularly on the critical and highest costs components, and any items which may pose hazards to equipment or the health and safety of site personnel and to document the condition of the turbines and related equipment for future reference. Claims may result in component replacement or commercial changes to ensure the owner is protected, e.g. an extended warranty on a particular component. Some amount of normal wear and tear should be expected and will not necessarily impact the ability of a component to meet its design life or result in a successful warranty claim.

Purpose and Scope

(continued)

The purpose of this document is to describe recommendations for warranty management and the most appropriate techniques used in EOW inspections. These practices, if properly applied, should lead to the submission of well-documented warranty claims and facilitate effective warranty management.

Introduction

There are many factors and timeframes to consider when planning for effective management of various warranties. There are contractual elements that influence the process, e.g. a serial defect clause may have a different timeframe for exercising rights than the overall warranty timeframe. Main warranty elements of a typical wind project may include the following:

- EPC contractor workmanship
- BOP equipment
- Turbine equipment
- Turbine performance, e.g. sound and power

Management of some of the sub-elements of the main items listed above is more reactionary, whereas others require more pro-active planning, testing, and inspection in order to exercise and maximize warranty rights. However, in all cases, awareness of the various warranty elements and timelines is essential.

The scope of an EOW inspection campaign can range from minimal to complex depending on the time and cost constraints and the interest of the project owner. In addition, utilizing a reputable independent third-party for inspections may add more credibility to the findings. A wide variety of inspection techniques are available and the project owner must decide which are appropriate for their situation. Known issues may exist with a particular component, warranting specific inspection techniques that may not be necessary in all cases. Many equipment warranty items are OEM dependent and industry user groups can provide a useful forum for leveraging pooled information. This can help in warranty claims and in tailoring the end of warranty approach to pre-manage specific known issues. For large projects, it can be beneficial to conduct a diverse range of inspection tasks on a sample population of turbines prior to the full-scale inspection campaign. This can establish the most critical tasks and determine the scope of inspections to be conducted for the entire project.

Introduction

(continued)

Individual inspection tasks during the complete EOW inspection campaign can be completed on 100% of turbines on a project or on a smaller sample population, depending on the criticality, cost, and time required for the particular task. While project-specific circumstances will vary, the best practice is to inspect 100% of major components or any component where there is potential for a serial defect claim. It is advisable that owners take their serial defect threshold definitions into account when deciding how many turbine components to inspect. Some inspection tasks may only be triggered if a problem is identified by other means. For other components, or for QA/QC inspections, the owner should evaluate their risk tolerance, the risk, and their serial defect threshold definitions to decide whether to use 100% inspection or a sampling approach. Evaluation of supervisory control and data acquisition (SCADA) data and review of parts usage at the project is recommended for identifying components or turbines that warrant additional targeted attention during EOW inspections.

Inspections may be conducted by independent third-party organizations, the project owner, or combinations of several groups with specialized skill sets. Representatives from the OEM and/or owner may accompany inspection teams or teams can operate independently. Best practice is to involve site staff, owner's engineers, and the OEM during the initial inspections so the processes can be reviewed and agreed upon by all parties at the onset of inspections.

Inspections are a human process with some subjectivity in discerning between normal wear and tear and actual claims. Note that inspectors generally do not inspect certain items to avoid disturbing their condition. Power performance testing or sound testing may also be considered.

Timing and Planning

Points to consider:

- Contractual elements, such as turbine-by-turbine warranty timing, may not coincide with project wide timing of warranties. Note that serial defect warranty timing may not align with other project warranty timing.
- Consider conducting end of warranty inspections following a maintenance cycle so the inspections can focus more on warranty items rather than items that will be picked up during maintenance.
- Consider timing inspections to maximize the warranty period while allowing sufficient time to make claims.
- Pick timing that will minimize lost energy production due to inspection activity.

Timing and Planning

(continued)

Points to consider:

- Timing of tests may require steps to be initiated prior to completion of construction, e.g. power performance test site calibration, if required.
- Consider effects of daily scheduling, e.g. early morning shifts help avoid the hottest times of day.
- Consider major component spares that may have time-based maintenance and associated warranties.

Balance of Plant (BOP) End of Warranty Inspections

The expiration of warranties for balance of plant equipment and installation may or may not coincide with the wind turbines' OEM warranties. Planning the EOW inspections for the balance of plant should be a consideration. The balance of plant EOW will include the collection system, substation, civil site improvements, O&M building, and met mast.

1. Procedure

1.1. Obtain a complete drawing package for collection system to ensure correctness and completeness.

1.2. Determine the expiration dates and allow for sufficient time to conduct the inspections, analyze the results, and file any necessary claims.

1.3. EOW inspections should include a review of the contractor turnover package and site maintenance documentation to understand the as-built condition and what has occurred while the equipment and site were under warranty.

1.4. Based on a review of the documentation as mentioned above, determine the scope and scale of the BOP inspection. Inspections may be for the total site or a representative sample of each area.

1.5. Agree on the personnel that will be involved: OEM technicians, third-party inspection, site operator, and owner's representative.

2. Safety

- 2.1.** Provide suitable safety precautions and protection per Occupational Safety and Health Administration (OSHA) regulation and appropriate consensus standards during field testing. Only trained and qualified personnel shall operate test equipment.
- 2.2.** All lock out/tag out (LOTO) procedures shall be strictly adhered to, along with minimum approach.
- 2.3.** Markings/labels for safety should meet all codes.
- 2.4.** Ground equipment and discharge to make them safe after high potential testing.
- 2.5.** Arc flash detector should be tested to meet original operational standards and industry regulator requirements.
- 2.6.** Fire extinguishers should be certified and record keeping should be in place to meet International Code Council (ICC) Section 306 Factory Group F, which requires 30-day testing or electronic monitoring.
- 2.7.** Ensure the project site and equipment OEM safety procedures are followed.
- 2.8.** Visually monitor for excessive housekeeping issues, such as signs of grease or oil spills and general uncleanness leading to masked problems.
- 2.9.** Reference the “*AWEA Qualified Electrical Worker Guideline and Unqualified Electrical Worker*” document.

3. Pad Mount Transformer (PMT)

- 3.1.** As a wind power generation component, the PMT is developing a history of causing outages. This should be a component of particular attention for EOW.
- 3.2.** Audible testing for transformer wear and tear that could result in catastrophic damage should be performed prior to opening cabinet.
- 3.3.** Visually inspect the exterior noting: levelness and integrity of the pad and ground rod connections, condition of the surrounding backfill, condition of barrier posts, evidence of corrosion, encroachment of vegetation, evidence of oil leakage, and paint.
- 3.4.** Inspect the pads and/or vaults.
- 3.5.** Bollards/fences shall be installed and in good operational condition to protect from vehicle and large animal intrusion to the outer enclosure.
- 3.6.** Proper grouting and leveling of transformer opening in the ground should be inspected using appropriate ground leveling techniques. Suitable products should be added to ensure outside elements such as dirt/dust, moisture, and living insects and animals cannot get into the space.
- 3.7.** Proper cable conduit fill materials should be used to ensure moisture, insects, and animals cannot get into the air space compartments through these items. Common putty does not work when heated and deteriorates.
- 3.8.** Original oil containment systems should be inspected and repaired. If no containment is installed originally, a plan for reaction to oil spills should be in place.

4. De-Energized-Energized Inspection and Pre-Turnover Testing

- 4.1.** Energized and de-energized check the oil. Transformers should have gauges for level, minimum, and maximum temperature.
- 4.2.** Pre-turnover test should be made for dissolved gas analysis (DGA) and comparison or trending of the DGA reports.
- 4.3.** Energized with load infrared (IR) scans of terminations to check for connection integrity or load imbalances, preferably at greater than or equal to 75% load.
- 4.4.** Non-energized test of tap changer should be cycled for confirmation of smooth movement.
- 4.5.** NO-LOAD energized test of tap changer should be cycled for confirmation of smooth movement using appropriate safety equipment.
- 4.6.** Non-energized ON-OFF-alternate POSITION changer should be cycled for confirmation of smooth movement.
- 4.7.** Energized ON-OFF-alternate POSITION changer should be cycled for confirmation of smooth movement using appropriate safety equipment.
- 4.8.** Energized operational tests should be conducted in accordance with International Electrotechnical Commission (IEC) and/or American Society for Testing Materials (ASTM) standards using appropriate safety equipment.
- 4.9.** Low voltage (LV) connections should be torque tested. Cable connections to connectors should be inspected for heat damage and other wear.
- 4.10.** Medium voltage (MV) connectors should be removed and cleaned to properly inspect for arcing and other deterioration. Darkening for heating should be checked. MV bushings should be visibly inspected for arcing and deterioration. Grounding of connectors should be inspected and repaired as necessary. Replace questionable connectors. MV surge arrestors should be visibly inspected for wear and tear. Testing is not generally performed.

4.11. Low voltage (LV) and high voltage (HV) bushings should be checked for visible arcing and oil leaking. Check for gravitational pulling on cables that could potentially result in bushing leaks. Cable mounting systems should be installed to preclude or eliminate leaks.

4.12. LV circuit breakers, where used, shall be inspected according to the manufacturer's maintenance and operations specifications. Visually inspect terminations, mounting connections, cleanliness from dust, corrosives, and evidence of living matter. Manually inspect operation of breaker and complete factory service as prudent or required.

5. Collection System

5.1. Review as-built drawings and verify installation of underground system from contractor turnover documentation. Ensure as-built meets the standards of the engineer's drawings. Record deviations.

5.2. Obtain a full list of components and develop a necessary spares inventory.

5.3. Review full incident history of collection system faults, trips, and repairs.

5.4. Overhead systems:

5.4.1. Develop a fill list of components of poles and hardware including torque specifications weights and measures.

5.4.2. Develop a critical spares list for inventory needs and turnover spares requirements.

5.4.3. Visually inspect wooden poles for degradation from construction or environment.

5.4.4. Visually inspect insulators, cross arms, arrestors, and overhead connectors for structural integrity and electrical wear and tear, arcing, and corrosion.

5.4.5. Inspect all cable connections for wear and proper installation methods.

5.4.6. Inspect the overhead system for proper catenary of the cabling.

5.4.7. Use Thermal Imaging on each electrical connection for hot spots.

5.4.8. Disconnect switches should be operated de-energized. The fuse should be verified as to operation and proper size per drawings and engineering requirements.

5.4.9. Instrument transformers such as current transformers (CT) and voltage transformers (VT) should be visually and mechanically inspected. Ratio tests should be made according to the manufacturer's standards and engineering requirements.

5.4.10. Automatic pole mounted equipment should be inspected visually for damage and connections. The device should be mechanically and electrically operated while de-energized and while energized per manufacturers operating instructions and wind farm grid operator advice.

5.4.11. Cable risers for underground cables to pole line should be inspected de-energized for integrity of electrical and mechanical connections including any cable covers, cable hanging methods, jumper connections and cleanliness of insulators. IR testing inspection should be used during energized and under power certification of integrity.

5.5. Underground system

6. Develop a fill list of components, poles, and hardware including torque specifications, weights, and measures.

-
- 7.** Inspect junction boxes for mechanical integrity and operation including:
 - 7.1.** Level
 - 7.2.** Surrounding earth integrity
 - 7.3.** Electrical grounding integrity
 - 7.4.** Paint
 - 7.5.** Fault indicator operation and integrity including viewports when used
 - 7.6.** IR test when energized and under load
 - 7.7.** Wear and tear on mechanical devices and bolting locations
 - 7.8.** Visible inspection of MV connectors and cable including evidence of arcing, excess wear, cuts, or physical damage
 - 7.9.** Manual application of cable connectors to ensure they are not too loose or too tight (won't rotate or remove)
 - 7.10.** Inspection of arrestors and other apparatus inside or outside enclosure
 - 8.** Visually inspect cable splices (if available) and terminations.
 - 9.** Perform IR Scans and/or bolt torque tests in accordance with the EOW plan.
 - 10.** Perform VLF system testing after component acceptance testing is complete to verify that all cabling systems operate properly.
 - 10.1.** Notify owner/customer in advance to allow witnessing.
 - 10.2.** May also include partial discharge (PD) testing on collection systems.

11. Substation

11.1. All applicable inspections and test reports shall become part of the EOW documentation to the owner/customer.

11.2. Grounding system:

11.2.1. Use instruments to test for proper ground value per engineer's requirements.

11.2.2. A visual and mechanical inspection of grounding system shall be conducted to ensure grounding cable, ground rods, and exothermic or mechanical ground connection(s) are in compliance with engineer drawings and specification.

11.3. Foundations:

Conduct a visual inspection noting: levelness and integrity of the pad, condition of the surrounding backfill, condition of barrier posts, evidence of corrosion, and encroachment of vegetation to ensure foundations are consistent with design requirements. Include bolt torque checks.

11.4. IR scans:

11.4.1. IR scans are effective when above about 75% load.

11.4.2. Scan the entire substation looking for temperature anomalies. Check all electrical connections in the substation yard, as well as in the control house.

11.4.3. Weather conditions can be very important and can mask potential issues. Bright sun, significant wind, or precipitation can affect thermal imaging inspections. Note the conditions during the inspection.

11.4.4. Inspect the bushings. Look for heat in the external connections, internal connections, in the bushing head, and connections to the coils.

11.4.5. Check the surge protection. Look at segmented signatures with small rises in temperature as indicators of serious problems.

11.4.6. Inspect the cooling systems. Blockage or low oil in radiators will show up as cool tubes.

11.4.7. Inspect the fans after they have operated for 15 minutes or more.

11.4.8. Check all oil-filled circuit breakers (OCB) and voltage regulators. Check the tank differentials top-to-bottom and tank-to-tank.

11.4.9. Inspect all disconnects and switches.

11.5. Circuit breakers:

Inspect and test per OEM manual; ensure properly commissioned. Check for loose wiring connections and perform full functional and insulation testing.

11.6. Current transformers (CTs):

Confirm CT ratios and metering accuracy.

11.7. Metering equipment:

Confirm accuracy with secondary meter.

11.8. Voltage transformers/potential transformers:

Check oil levels and electrical connections. Verify secondary voltages.

11.9. Capacitor banks:

Confirm all connections. Visually inspect all packs for bulging and leaks. Verify bank capacitance.

11.10. Battery banks and charging systems:

Check all cells for plate damage. Test for internal resistance and specific gravity of each cell. Verify battery charger operation by applying charge cycle to battery bank.

11.11. Reactors:

Check all connections and perform a visual inspection for any abnormalities.

11.12. Generator step-up transformer (GSU) main power transformer:

11.12.1. Verify condition of all control cabinet wiring.

11.12.2. Perform partial discharge testing.

11.12.3. Perform dissolved gas and comprehensive oil analysis on the main tank and load tap changers (LTC) compartments.

11.12.4. Check for oil leaks and oil levels on all oil compartments and all oil filled bushings.

11.12.5. Perform complete power factor (PF) testing to confirm winding and bushing insulation condition.

11.12.6. Perform exciting current and leakage reactance impedance tests.

11.12.7. Analyze LTC condition based on oil sample and heat signature data.

11.12.8. Verify all alarms and transformer trip circuits.

11.12.9. Verify correct connectivity and operation of the controls building and communication systems.

11.12.10. Verify relays (hardware and software). Verify all software versions are up to date. Verify all relay operations and trip paths. Verify all relays & meters (pickups, timing, logic, SCADA, and targets), functional trip/close, and I/O testing.

11.12.11. Verify operation and condition of all sump and secondary containment systems.

12. Civil Site Improvements

12.1. Review the storm water pollution prevention plan (SWPPP). By this time the construction plan should have been converted to a post-construction storm water management practice plan.

12.2. Inspect the site best management practices (BMP) for adherence to the SWPPP.

12.2.1. Ensure that the temporary construction BMPs have been removed.

12.2.2. Ensure that the permanent storm water management structures are in place and void of construction sediment.

12.3. Inspect the site roads, culverts, and bridges for structural soundness. This may also be an opportune time to mitigate any unforeseen erosion or other issues.

12.3.1. Ensure that the road width is in accordance with site permits.

12.3.2. Ensure that reclaimed construction areas are properly vegetated.

12.3.3. Ensure that the areas adjacent to each wind turbine are in accordance with the design and local requirements.

12.3.4. Look for areas of erosion. Ensure proper drainage.

1.13. Meteorological Tower

13.1. Review the commissioning documentation.

13.2. Establish protocols and execute inspections to verify operational accuracy.

13.3. Inspect foundation, guy wires, and anchor points for structural integrity, condition of the backfill, and condition of the surrounding immediate area.

13.4. Visually inspect the tower looking for structural faults and corrosion.

13.5. Ensure that cabling is installed in accordance with the design parameters.

13.6. Ensure that all instruments are working as designed.

13.7. Check power supply and any backup power. Check communications.

13.8. Check that FAA lighting functions appropriately. Verify record keeping for FAA requirements.

14. Operations and Maintenance (O&M) Building

14.1. Verify permits are in order.

14.2. Verify all drawings and documentation are available and in order for all equipment.

14.3. Inspect the structural components of the foundation and building for structural integrity.

14.4. Inspect each operating system: safety, electrical, plumbing, computer, and communications for adherence to the design, drawings, and use of specified or accepted components.

14.5. Check oil storage areas for containment, ventilation, and compliance.

14.6. If applicable, the back-up generator may have a warranty.

15. Gen-tie Line

15.1. Insulator IR scans and visual inspections

15.2. Structural integrity

15.3. Static line (lightning protection)

15.4. Communication line

15.5. Conductor line sag

15.6. Avian deterrents

15.7. Bird diverters, if applicable

16. Communications/SCADA

16.1. Verify redundancy is functional

16.2. UPS

16.3. Cooling system functionality, if applicable

Wind Turbine End of Warranty Inspections

1. Common Inspection Items

1.1. Safety Equipment

Depending on the scope of supply, the warranty may be with the turbine OEM or with the equipment supplier. Items may include:

- Markings/labels for safety should meet all codes.
- Switchgear and transformer arc flash detectors
- Ladder and safety cable (limited fall arrest system) and lifts
- First aid kits complete and dated
- Fire extinguishers
- FAA lights
- Emergency descent devices (check for wear and tear and meeting standards from OSHA and other safety regulators.)
- Housekeeping and spills can be indicative of issues.

1.2. Drivetrain

1.2.1. Gearbox

Borescopes are commonly used to document the condition of gear teeth and bearings within the gearbox. Borescope inspection is recommended for gearboxes. Borescope images should be taken in all accessible areas of the gearbox, regardless of whether or not damage exists, to document the condition. Images should include the gearbox nameplate, and reference photo cards should be used to identify each section of the gearbox. Images of each component should be taken in a consistent order for all gearboxes. Areas of the gearbox that cannot be accessed should be noted, and images of obstructions taken where appropriate, such as a bearing cage blocking inspection of bearing races.

Image quality should be the most important factor in borescope selection, as some borescopes are inadequate for wind turbine gearbox inspections. The rigidity of guide tubes, lens cleanliness, the type and quality of light, and, particularly, technician training, all affect image quality.

The time required for a borescope inspection is highly variable depending on access, operator skill level, and the number of positions in which the gearbox will be stopped to permit inspections.

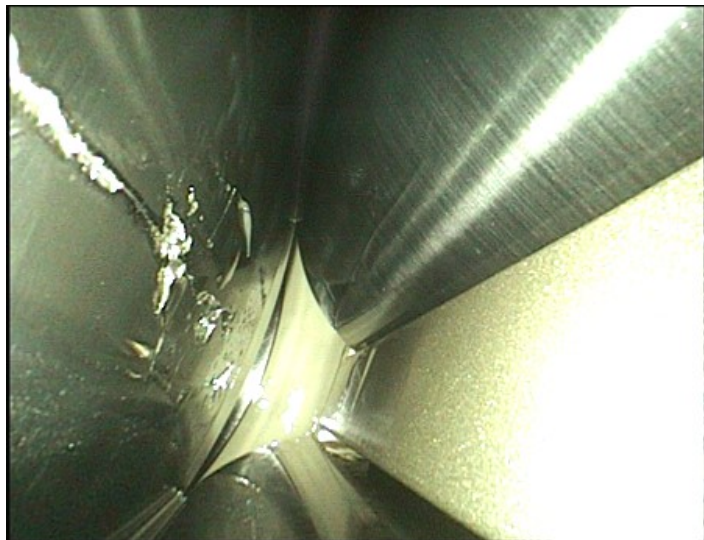

Figure A: Example of Damage to the Inner Race of a High Speed Bearing Documented with a Borescope.

1.2.1 Gearbox

(continued)

Additional elements of a gearbox inspection should include visual inspection of the housing for cracks and leaks, damaged ancillary equipment, oil level in the sight glass, and magnets. Any abnormal color, smell, or foam in the oil should also be noted at the time of inspection.

1.2.2. Main Shaft

Visually and functionally inspect the brake assembly for proper operation. This can include making sure that rotor locking pins can be inserted correctly and that the brake operates as expected.

Visually inspect the high-speed flexible coupling between the gearbox and generator. Verify that bolts have torque marks and that the coupling has been aligned and installed correctly according to the coupling OEM's installation manual.

1.2.3. Main Bearing

Visually inspect the main bearing and record any signs of leakage from the seals. Inspect the grease trap and note signs of excessive grease or grease that is discolored or appears shiny. Grease samples can be taken from the main bearing and sent to a lab for analysis.

Temperature trending of the main bearings can also be used to target certain bearings for inspection. Signs of gradual temperature rise over time or temperatures that appear higher than the rest of the site are good candidates for further inspection.

Vibration analysis can also be done on the main bearing. It is important to note that, since the main bearing is a low-speed component, this analysis is limited in its effectiveness in finding issues and will need to be done in concert with the other inspection techniques described in this section.

A borescope may also be used in some cases to look at the internal sections of the main bearing. This can provide detailed pictures similar to gearbox borescopes showing internal damage.

1.3. Bland Inspections: Done

Visual inspection of the blade surface is commonly conducted from the ground and at the blade surface using various access techniques. One hundred percent of turbine blades should be inspected. Each blade should be photographed with images covering the entire surface and from different angles so the leading edge, trailing edge, and high and low-pressure surfaces are all clearly visible. Using a camera is preferable to a spotting scope or binoculars, as a camera provides documentation that can be reviewed by others and, in some cases, damage may not be evident until post processing of the images is done. Drone camera inspections are also an option and may be more cost effective depending on the site conditions present. Several (5-10) complete rotors can be completely documented by an experienced crew in a day. Inspection of all blades is recommended.



Figure B: Example of Blade Damage Documented with Ground-based Digital Photography.

1.3. Bland Inspections - Done

(continued)

Direct access inspections, e.g. ropes, platforms, boom trucks, etc., can be used to detect damage that may not be visible in ground-based images, e.g. small cracks. In some cases, the extent of damage may not be clear in ground-based images and can be clarified through direct access inspections. Ultrasonic testing (UT) or other non-destructive techniques that can detect the presence of other defects and voids in adhesive bonds can also be performed during direct access inspections. A single crew can typically inspect 1-2 rotors per day but these inspections impose greater limitations on safe working conditions, e.g. wind speed limits, so a sample of 10-20% of the project is often more feasible.

It is recommended that the inspections ensure that the lightning protection system (LPS) is functioning as intended.

Consider whether internal blade inspections are required noting this may be considered a permit required confined space.

1.4. Turbine Electrical

Verify all power connections are tight to manufacturer's requirements. Verify general cleanliness of enclosure(s) interior. Inspect all wiring, power, and control for evidence of high heat and poor connections at each end. Verify communications wiring is in good condition and properly physically placed and connected. Verify sub-distribution equipment including contactors, circuit breakers, fuse/holder, terminal blocks, surge arrestors, transformers, fans, capacitors, and all other operation-critical components are in good working condition.

1.4.1. Power Converter

Visually inspect the power converter of the turbine and ensure that all wiring is organized, routed, and terminated correctly. Inspect wires for signs of damaged insulation and note any wires that are not labeled at the spot of termination. This may indicate the presence of a jumper wire that may be bypassing certain controls.

1.4.1. Power Converter

(continued)

Verify all power connections are tight to manufacturer's requirements. Verify general cleanliness of enclosure(s) interior. Inspect all wiring, power, and control, for evidence of high heat and poor connections at each end. Verify communications wiring is in good condition and properly physically placed and connected. Verify sub-distribution equipment including contactors, circuit breakers, fuse/holder, terminal blocks, surge arrestors, transformers, fans, reactors, capacitors, and all other operation-critical components are in good working condition. Check for cleanliness internally and externally.

From records or onboard database, review the number of operations and various trip reasons looking for high energy trips to resolution. Verify factory required maintenance performance schedule. Verify wiring of accessories are tight and clear of heat or fault damage. Test according to manufacturer's instructions.

Visually inspect the heat exchanger system and note any signs of damage to the cooling fins or fans used to remove heat from the power converter. Verify cooling system is fully operational to factory and manufacturers standards. Note replacement history records indicating repetitive failure modes and results.

For liquid-cooled power converters inspect for signs of leakage and ensure that the system has been filled to the correct level and purged of air for proper operation.

1.4.2. Medium Voltage (MV) Switchgear, Where Used

Complete battery of operational testing per manufacturer's requirements including remote trip mechanism and system. Visually inspect accessory wiring, MV connections, and communications, where used.

1.4.3 MV Uptower Transformers, Where Used

Complete battery of operational testing per manufacturer's requirements. Visually inspect MV connectors for wear and damage. Visually inspect for signs of rust and/or oils. Monitor gauges when available. Inspect accessory wiring and accessory monitoring equipment where used. Perform insulation test.

1.4.4. Low Voltage (LV) Control

Work from as-built drawings and factory specifications to inspect:

- **Main Power Panel:** Visually inspect exterior of main control panel breakers for wear and tear, corrosion, and functionality of moving mechanical parts.
- **Main Circuit Breaker:** Check for cleanliness externally and internally. Verify from records or onboard database number of operations and various trip reasons looking for high energy trips to resolution. Verify factory required maintenance performance schedule. Verify wiring of accessories are tight and clear of heat or fault damage. Verify proper lubrication. For draw-out breakers perform complete in/out operation visually inspecting tracks, motion, lubrication and the electrical contacts and connections are in good working order within wear standards. Test according to manufacturer's instructions.
- **Main Contactor:** Check for cleanliness externally and internally. Verify from records or onboard database number of operations. Verify factory required maintenance performance schedule. Verify wiring of accessories are tight and clear of heat or fault damage. Verify proper lubrication. Perform complete operation visually inspecting tracks, motion, lubrication, and the electrical contacts are in good working order within wear standards. Test according to manufacturer's instructions.

1.5. Walk-Down Inspection

A walk-down inspection of the complete turbine is recommended to document safety issues, the general turbine condition, and component failures. Walk-down inspection is recommended for 100% of turbines. A common checklist and rating system for findings to be used for all turbines on a project should be developed with input from the inspection team, owner, site managers, maintenance staff, and the OEM. Checklists provided by the OEM for regular maintenance are a useful starting point for development of the walk-down inspection checklist. Digital images of any observed damage should be collected in addition to the checklists.

1.5. Walk-Down Inspection

(continued)

Inspection crews should have access to turbine controls to be able to test certain systems for function, such as yaw motors, fans, pumps, and brakes. A walk-down typically includes inspection of cables and general housekeeping and checking valves for leaks and function. Some areas of the turbine require specialized training or equipment to access, such as transformers located in nacelles.

During the walk-down inspection, it is recommended to conduct calibration checks of turbine alignment into the wind and calibration of pitch angles. Nacelle and tower inspection checklists are recommended to include inspection structural elements including inspecting the bed plate, tower welds, nacelle structure, nose cone, and fiberglass for cracks.

During the walk-down, check for corrosion on tower sections, cracks in grout (if in use), bolt covers for integrity, and any peeling coatings or corrosion particularly at the touch-up areas. If required, conduct pull tests to ensure bolts meet proper pre-load.

During the walk down inspection, inspect the full array of tower components including heating systems, insulation, anchor points, filters, louvers, decks, hatches and doors, and gantry cranes.

Check for appropriate storage of nacelle access ladder, if applicable.

For the turbine hydraulic, inspect hydraulic water and oil systems of the pitch, yaw, oil cooling, generator cooling, electrical connections, and monitoring for operation, leakage, and general uncleanliness, which may indicate unresolved problems.

All bushings require visual inspections, grease inspections, leak inspections, and a check of the torque marks.

1.6. Retrofits/Upgrades/Software/Firmware

As part of the end of warranty process, it should be confirmed that all applicable manufacturer retrofits and upgrades have been implemented at the site. Best practice includes auditing the software, firmware, and programmable logic control (PLC) programming revisions on each turbine to confirm they are consistent and up-to-date. This recommendation also applies to converter software.

1.7. Pitch System

The type of pitch system (hydraulic or electric) will dictate the specifics of the appropriate inspection methods. Samples of hydraulic fluid may be taken for analysis. Battery systems may require inspections.

- Pitch bearing grease samples may need to be taken.
- Inspect pitch system control cabinets and hardware. Verify mounting system integrity.
- Inspect teeth for wear and cracks.
- Inspect pitch encoder position.
- Inspect pitch accumulators and cylinders for integrity, leaks, appropriate fill levels, dust covers, and oil leaks.
- Inspect pitch motors, gearbox, batteries, and chargers.

1.8. Yaw System

- Where applicable, check puck measurements for uneven wear and cracks.
- Visually check yaw encoder.
- Inspect for excessive wear or cracks in gear teeth.
- Inspect motors, gearboxes, drives, and braking system.
- Inspect the lubrication system.
- Inspect yaw bearing grease samples as applicable.

1.9. Lubricant Sampling and Testing: Done

Sampling and testing of gearbox oil and main bearing grease should be conducted as part of the EOW inspection if this is not already being done as part of regular maintenance or if laboratory reports are not made available to the project owner. Laboratory testing can identify wear metals in the lubricant, the condition of the lubricant itself, and may indicate possible damage to the equipment. The presence of water, changes in viscosity, and additive breakdown can result in a failure of the lubricant, which is, in itself, a critical system. Hydraulic oil, blade bearing grease, and other lubricants may also be sampled and tested as needed. Detailed procedures for lubricant sampling and testing are described in RP 812 and RP 813.

1.10. Generator Testing and Inspection

Electrical testing of the generator can be done with specialized tools and may detect problems with winding insulation, although the ability of these tests to predict failure is limited. A description of specific tests can be found in RP 203. The condition of generator cable terminations may also be inspected and signs of previous arcing identified during testing.

In some cases, it may be possible to inspect generator internals with a borescope, where evidence of arcing, dust generated from loose wedges, and excess grease or debris may be observed and documented. Consider inspections for fatigue cracks of components, the insulation, and windings with a borescope. A generator alignment check may be conducted. Reference “Collector Assembly (Slip Rings and Brushes)” in RP 201. Also reference “Generator Alignment” in RP 205.

1.11. Vibration Measurement: Done

Vibration data, also called condition monitoring system data, can be valuable in detecting faults in parts of the drive train that may not be otherwise accessible. Data from a permanently installed system are preferable as they allow for long-term trending; however, portable vibration systems which can be installed temporarily for EOW inspections may still detect many faults. Vibration data alone will typically not be sufficient to make a warranty claim, but identification of faults through vibration may trigger additional focused borescoping or other inspection techniques which may be impractical to conduct site-wide, such as a partial bearing disassembly and cleaning. Additional information on vibration measurement can be found in RP 204 and RP 811.

2. EOW Inspection Schedule

Inspections should be planned such that delivery of final inspection reports can be made well before the warranty expiration; however, warranty claims can be made at any time before the expiration if sufficient evidence is available. Consult the project contacts to be aware of notification and any timing requirements. Warranty claims will need to be reviewed by the OEM, and not all claims will be accepted, so including ample time for discussion after claims are made but before the warranty has expired is critical. Planning for delivery of inspection results prior to the warranty expiration is considered best practice. Note that notification for serial defect claims should be made as soon as the thresholds are reached; this should not wait until the end of the contract period.

Multiple teams with specialized inspection skills may be deployed across the site and the sequence of deployment is critical to ensure the initial teams provide information to subsequent teams. For example, ground-based blade inspections will inform the choice of turbines that receive direct-access blade inspections. Inspection teams should be given complete access to the turbines and trained to safely stop and control equipment as required for inspections.

3. EOW Reporting

Large amounts of data are generated during an inspection campaign and it is critical to distill the raw data into reports that can be used by project owners to make claims and provide sufficient information for the OEM review. A project-wide executive summary should be produced that identifies the most critical observations and patterns of abnormal wear or damage. The summary report should describe the inspection methods and tools used, nomenclature employed, criteria for classifying observations, photographs, and inspection coverage for all tasks.

Detailed individual turbine reports for each inspection task should also be generated which clearly document the observed conditions. These detailed reports should document the make, model, and serial number(s) of major components, date of inspection, tools used, and the names of the inspectors. For example, each turbine should have a unique borescope inspection report that includes representative images from each section of the gearbox and clearly identifies any damage.

3. EOW Reporting (continued)

All raw data should be retained and provided to the project owner. These data may be required during the claim process and can be used to benchmark the turbine condition for future reference.

Users need to decide on the amount of data they want to collect.

Summary

Proper EOW management and inspections are effective for documenting the equipment condition in detail prior to warranty expiration and should be performed on all wind projects. A large number of inspection techniques can be deployed as part of an EOW inspection campaign and project owners must consider which are appropriate for their project.

Chapter 8 Condition Based Maintenance



Operations and Maintenance
Recommended Practices

version 2017

RP 801 Condition Based Maintenance (CBM)

The following recommended practice (RP) is subject to the disclaimer at the front of this manual. It is important that users read the disclaimer before considering adoption of any portion of this recommended practice.

This recommended practice was prepared by a committee of the AWEA Operations and Maintenance (O&M) Committee.

Committee Chair: Junda Zhu, NRG Systems
Principal Author: Junda Zhu, NRG Systems

Purpose and Scope

The scope of “Condition Based Maintenance (CBM)” provides an overview of the condition based maintenance strategy and examples of some of the existing technologies utilized to perform condition monitoring on wind turbines. This document serves as the introduction and foundation for the rest of the 800 series of recommended practice chapters. For further detail on any of the specific technologies mentioned in this chapter, please look into the rest of the RP 800 series.

Introduction

Following in the footsteps of other industries, the wind energy industry operations and maintenance have been evolving towards predictive maintenance strategies to maximize the turbine availability while minimizing the production interruption due to operational failures. A conventional event-based maintenance strategy is recognized to be not as optimal due to unexpected shutdowns and potential safety concerns related to the catastrophic failures with no early warnings. On the other hand, scheduled based maintenance, while it significantly improves the turbine availability, still falls short on cost optimization since failure occurs in between the maintenance cycles.

Introduction

(continued)

As the wind industry is exploring territories that are much more remote, drive train operational situation awareness is considered crucial for turbine availability and maintenance cost optimization. Predictive maintenance strategy based on condition monitoring technologies is considered the direction where the industry is moving. Predictive maintenance is scheduling maintenance action based on the actual or projected condition of a single component or the overall turbine operational health condition. Hence, this is also referred to as condition based maintenance. The maintenance activities at the site are only carried out when it is necessary or convenient. The condition of the component can be assessed through a variety of condition monitoring technologies, such as those commonly seen in vibrations analysis and particle counters, among others.

With the help of properly instrumented condition monitoring hardware and algorithms, the operator will have full situational awareness and overview of the operational condition down to critical components of the turbine. With the information available from these systems, the maintenance team can optimize the maintenance activity and decide the right time to service the right component. Hence, the maintenance cost along with the turbine downtime can be greatly reduced. Establishing the right maintenance strategy and practices for your fleet can make the difference between a profitable operation versus one that is not.

Traditionally speaking, a properly deployed condition monitoring system involves many aspects including hardware instrumentation, data collection and storage system configuration, fault detection, diagnostic, severity assessment, prognostics, action recommendation, inspection/repair, and knowledge preservation. It is important for the end user of a condition monitoring system to understand these aspects in order to select a system that is capable and effective when deployed. The following list provides the end user a checklist to go over when choosing a system that fits their budget and needs.

Condition Based Maintenance Selection Checklist

1. Hardware Instrumentation

The hardware deployed should be carefully selected to match the section of components which the condition monitoring system is supposed to cover. The mounting location is also crucial for effective and accurate diagnostics. Orientation of the sensor, sensitivity of the sensor, and the measurement capability, e.g. spectrum range, should all be well selected for wind application.

2. Data Collection, Transfer, and Storage

Modern condition monitoring systems take measurements much more frequently than ever before. On one hand, data can provide insight of fault location and modes. On the other hand, if not careful, data accumulates in an uncontrolled manner and will result in high data storage cost. Collecting data more frequently than necessary will also increase the load on the data bus, which can potentially affect other critical information from being transmitted.

3. System/Sensor Configuration

The sensor needs to sample at the right frequency for the component it is monitoring and have sufficient resolution for the proper analysis. The configuration should also take into account the component kinematic if the information is needed for further analysis. The data collection triggering condition sometimes needs to be pre-defined as well.

4. Fault Detection

Early fault detection is one of the major advantages of instrumenting condition monitoring systems. To be able to achieve early fault detection, the proper algorithm needs to be integrated to capture early signs of degradation. The algorithm implemented should be designed specifically for wind applications that cope with the operational characteristics of a wind turbine. The correct fault detection algorithm should be able to provide consistent and stable readings of the fault signature in advance, allowing the operator enough time to react.

5. Diagnostics

Diagnostics, commonly referred to as fault localization and fault mode identification, is the analysis procedure to find the fault location as well as the type of fault. There are multiple algorithms developed using a variety of instruments to determine the fault mode. Different fault modes result in different maintenance priorities. For example, widespread scuffing damage should be treated more carefully compared to localized spalling. The user of the CMS system should also contact the supplier about what type of fault the system is capable of detecting.

6. Severity Assessment

Upon successful detection of the fault, the next question is the severity of the fault. There are multiple ways to assess the degradation level of the component. Some of the CMS suppliers use absolute references, like ISO 10816, while others set up statistical thresholding methodology among the fleet. The choice of methodology for severity assessment should be evaluated together with the corresponding measurement and its characteristics.

7. Prognostics

Prognostics, or remaining useful life prediction, is considered one of the most challenging topics in the industry and academia. Given the fault mode and severity, predicting the end of life for a component is always a difficult task. Various kinds of faults develop dramatically differently. While some of the faults may exist for years without interrupting production, others fail catastrophically in a very short period of time resulting in massive asset damage. Some algorithms that are specialized for prognostics are the Kalman/particle filtering algorithm and other statistical intensive methodologies. The prognostics algorithms are also subject to various measured parameters along with frequency of measurements.

8. Action Recommendation

The actionable information is one of the most valuable outputs a condition monitoring system can provide to the operator of a wind farm. Once the fault mode, severity, and the predicted remaining useful life have been estimated, it is the job of the CMS or the analyst to offer the operator some recommended action. Commonly given suggestions include: keep monitoring, inspect when convenient, inspect soon, etc. If the degraded component is not accessible for inspections, then repair or replacement should be considered.

9. Inspection/Repair

Once a recommendation is offered, the site team should inspect the affected component or service the component if inspection is not possible. This is normally done at the site level. If the component is replaced, it is sometimes quite helpful to let the CMS supplier know the make and model of the new component that was installed. On top of that, inspection pictures on the failed components can be very helpful for fine tuning the condition monitoring system.

10. Knowledge Preservation

No condition monitoring system is perfect. The diagnostics, as well as the severity assessment, should have the option to be fine-tuned using the feedback from the site team. Therefore, the inspection report along with the input from the inspection team ought to be reviewed in detail. Only by working with the maintenance team and communicating with the operator can a CMS be harnessed to its full potential.

10. Knowledge Preservation

(continued)

Condition monitoring solutions, when applied in the wind energy industry, must address some unique issues. Due to the stochastic nature of wind, the incoming wind speed and direction are almost always changing. This leads to fluctuating drive train speed and load. Combined with the complicated design of turbine components such as gearbox planetary section, it is crucial that a deployed condition monitoring solution can overcome such issues and provide accurate and consistent readings that can be interpreted to evaluate the health of the component. There are multiple commercial condition monitoring solutions available. RP 801 focuses on some of the key technologies in the wind energy industry.

Condition Monitoring Technologies

1. Vibration Analysis

Vibration analysis is one of the most commonly available condition monitoring solutions in the industry. The technology of using vibration to perform non-destructive evaluation has been implemented by a selection of industries since the 1960s. The hardware, along with the algorithm, has been refined over the years. Typical measurements are acceleration and velocity. The collected signal will be processed by time, frequency, or time-frequency domain analysis techniques to extract mechanical fault signatures. The conventional vibration signal processing method is designed for stationary machinery. When applied to the wind energy industry, it is crucial that the system compensates for the drivetrain speed fluctuation in order to obtain consistent results. RP 811 “Vibration Analysis for Wind Turbines” focuses on vibration based condition monitoring techniques and explains vibration analysis in detail.

2. Acoustic Emission

Acoustic emission, or AE, is the phenomenon of transient elastic wave generation due to a rapid release of strain energy caused by structural alteration in a solid material under mechanical or thermal stress. It is a solution for incipient fault detection using much higher sampling rate than vibration signals. There are also quite a few publications proving that this technology can provide early fault detection when compared with vibration analysis. However, due to the cost and high data sampling induced storage cost, the AE is not as widely implemented.

3. Debris Monitoring

Oil debris counter is one of the most commonly encountered CMS solutions. Recently, these measurements are normally taken in real-time. When fault occurs, metals are normally ground off the surface of the contacting surfaces. By monitoring the debris count in the oil flow, one can perform monitoring and fault detection of the drive train. RP 818 “Wind Turbine On-line Gearbox Debris Condition Monitoring” discusses this technique in detail.

4. Lubrication Oil Monitoring

Different from oil debris monitoring, lubrication oil condition monitoring monitors the oil health condition instead of the mechanical components. Oil analysis normally measures the cleanliness, water content, oxidation level, particle contamination, additive depletion, and many other key performance indicators. These indicators ensure that the oil is operating at its optimal condition. Lubrication oil health is crucial to a wind turbine gearbox. RP 819 “Online Oil Condition Monitoring” covers this topic.

5. Grease Monitoring

Apart from the oil-lubricated components in the gearbox, components like generator bearings, pitch bearings, and main bearings are normally grease lubricated. One of the solutions to monitor the health of these components is by monitoring the grease condition. The detailed procedure to collect and analyze the grease sample from components and the wind turbine drive train can be found in RP 812 “Wind Turbine Main Bearing Grease Sampling Procedures” and RP 815 “Wind Turbine Grease Analysis Test Methods”.

6. Temperature Measurement

Temperature is one of earliest developed indicators of component health. Bearing manufacturers have long been aware of the relationship between bearing temperature and bearing life. Because of this relationship, temperature can be used to monitor bearing conditions or other temperature sensitive components, such as generators. For further information please refer to RP 816 “Wind Turbine Temperature Measurement Procedures.”

7. Nacelle Process Parameters

Nacelle process parameter data is taken from process variables of the control system. Whether real-time data or data stored in a plant historian, this data provides valuable insight into the holistic condition of the turbine. For further information please refer to RP 816 “Wind Turbine Nacelle Process Parameter Monitoring”.

8. Electric Current Analysis

The reliability and availability of wind turbine electrical and electronic components are critical to minimize life-cycle energy cost and benefit project financials. From up tower generators to substations, electrical current analysis can be widely used for the health indicator of mechanical or non-mechanical components. RP 831 “Condition Monitoring of Electrical and Electronic Components of Wind Turbines” discusses electrical current analysis in detail.

9. Summary

The above mentioned condition monitoring technologies are merely a portion of what is available on the market today. Some of the other solutions have been mentioned in the rest of the recommended practice chapters. Systems tailored for the wind energy industry can ensure real-time health condition assessment coverage from the blades all the way to the non-drive end generator bearings. Most of the available systems take measurements periodically under certain operating conditions. For example, some of the measurements are only taken when the turbine is operating at a certain speed or at a certain section of the power curve. The frequency of measurement and the amount of data collected have to be balanced between necessity, the load on the data bus, and data storage cost, among other considerations.

Different systems provide different health information regarding the turbine. There is no one technology that is superior to the others. It is the responsibility of the owners and operators to evaluate the need of their wind farm and choose among all of the available solutions.

While acknowledging the advantages of implementing condition monitoring technologies for the wind energy industry, the challenges should also be discussed. When it comes to slow-moving sections of the traditional planetary gearboxes, the early fault detection of the planetary section, as well as the main bearing, has always been a difficult task for many CMS suppliers. The issue is caused by slow rotating speed and poor vibration transmission path. Hence, it is important to carefully select hardware and algorithm combinations for these sections.

The properly deployed CMS can provide vital information on the wind farm site operating status. When fully integrated into the site maintenance logistics, maintenance actions can be coordinated across the farm and service calls can be better planned and optimized. This will increase the turbine uptime while reducing the maintenance cost, hence maximizing the profit margin of the entire operation. Moreover, with early detection of degraded components or drivetrains, fewer catastrophic failures will occur, which increases the operational safety. Components are most likely to be operating at their optimal condition, which directly leads to improved annual energy production.

Summary

The production cost is vital to the survival of wind energy as a viable future renewable energy source. Condition based maintenance plays a critical role in the significant reduction of operational cost. A correctly and properly instrumented wind turbine condition monitoring system can offer full operational situational awareness to the operator. With the help of the CMS, maintenance action can be performed only when it is necessary or convenient. Some of the cost-intensive down tower repairs can be avoided by detecting the fault in the early stage and quick up tower servicing. Unplanned shutdowns can also be reduced to a minimum. The operator can optimize the fleet-wide maintenance activities by consolidating services with the health information of all of the similarly degraded components at hand. There is an initial investment on the CMS; however, the return on investment is becoming easier to justify due to the increased capability and reduced cost of modern condition monitoring technologies. Due to a wide range of available solutions in the market, it is crucial for the operator to select a system that is designed and tailored for the wind energy industry given its special needs.

Acknowledgement

A special thank you to Shawn Sheng from NREL for his contribution throughout the drafting stages of this document, which would not have been completed without Shawn's inputs as a condition monitoring specialist in wind applications.

References

- [1] S. Sheng, ed., "Wind Turbine Gearbox Condition Monitoring Round Robin Study – Vibration Analysis", NREL, Golden, CO, USA, NREL/TP-5000-54530, 2012.
- [2] F. P. G. Márquez, A. M. Tobias, J. Pinar, and M. Papaalias, "Condition Monitoring of Wind Turbines: Techniques and Methods," *Renewable Energy*, vol. 46, pp. 169-178, October, 2012.
- [3] S. Sheng and P. Veers, "Wind Turbine Drivetrain Condition Monitoring – An Overview," presented at Applied Systems Health Management, Virginia Beach, Virginia, USA, NREL/CP-5000-50698, 2011.
- [4] R. B. Randall, *Vibration-based Condition Monitoring: Industrial, Aerospace, and Automotive Applications*, Hoboken, New Jersey, USA: Wiley, 2011.
- [5] S. Sheng and W. Yang, "Wind Turbine Drivetrain Condition Monitoring, An Overview," presented at ASME Turbo Expo, San Antonio, Texas, USA, NREL/PR-5000-58774, 2013.
- [6] S. Sheng, "Wind Turbine Gearbox Oil Filtration and Condition Monitoring," presented at Tribology Frontiers Conference, Denver, Colorado, USA, NREL/PR-5000-65388, 2015.

RP 811 Vibration Analysis for Wind Turbines

The following recommended practice (RP) is subject to the disclaimer at the front of this manual. It is important that users read the disclaimer before considering adoption of any portion of this recommended practice.

This recommended practice was prepared by a committee of the AWEA Operations and Maintenance (O&M) Committee.

Committee Chair: Junda Zhu, NRG Systems
Principal Authors: Junda Zhu, NRG Systems

Purpose and Scope

The scope of “Vibration Analysis for Wind Turbines” introduces wind energy professionals to vibration analysis methods used to detect and analyze machine component failures. This guide does not intend to make the reader an analysis expert. It merely informs the reader about common vibration analysis strategies and methods and lays the foundation for understanding vibration analysis concepts for the primary rotating components on the drivetrain of a wind turbine.

This recommended practice focuses specifically on the use of vibration analysis and encourages the consideration of additional condition monitoring technologies as part of a comprehensive proactive maintenance strategy.

Introduction

The production cost of wind energy has decreased significantly, especially in recent years. According to the Department of Energy, the cost of wind energy has decreased more than 90% since the early 1980s. According to the American Wind Energy Association (AWEA), the cost of wind energy has dropped 66% in the past 6 years. One major factor behind the wind energy production cost reduction is that the maintenance strategy of the industry is evolving from schedule based maintenance to condition based maintenance, also known as predictive maintenance.

Introduction

(continued)

Vibration analysis is one of the most commonly implemented condition based monitoring solutions in the wind energy industry. The fundamental theory of analyzing vibration data was established in the 1960s, and vibration signal processing algorithms have been developing ever since. Back in the 1990s, time synchronous averaging algorithms were implemented which significantly increased the fault diagnostics capability on non-stationary machineries similar to a wind turbine drivetrain.

Due to the stochastic nature of wind, the wind turbine drivetrain operational speed and load is always fluctuating. Traditional fast Fourier transform (FFT) based analysis techniques are not as effective when it comes to components with frequent speed variation. Additionally, FFT techniques are not capable of detecting non-periodical impacts in noisy environments such as gear fault signatures. The advantages of a well-instrumented vibration analysis, when compared with other practices, is the capability of early fault detection and fault localization in an online, real-time manner.

There are several key aspects of vibration analysis for wind turbines including:

- Component coverage
- Sensor selection and configuration
- Sensor mounting
- Signal processing techniques
- Alarm setting or thresholding techniques
- Data interpretation
- Severity assessment

On top of these, there are several vibration standards commonly referenced by the industry. This article will discuss them in the following sections.

Component Coverage

Normal commercial condition monitoring systems have the capability of covering most of the drivetrain components. The bearing components include: the main bearing, carrier bearing, planetary bearing, low-speed shaft (LSS) bearings, intermediate speed shaft (ISS) bearings, high-speed shaft (HSS) bearings, and generator bearings. A list of component shafts include: the main shaft, carrier shaft, planetary shaft, LSS, ISS, HSS, and generator shafts. The geared components include: the ring gear, planetary gear, intermediate pinion, intermediate gear, high-speed gear, and high-speed pinion. All of the components mentioned above are shown in Figure A. Normally, one vibration sensor is assigned to monitoring an assembly.

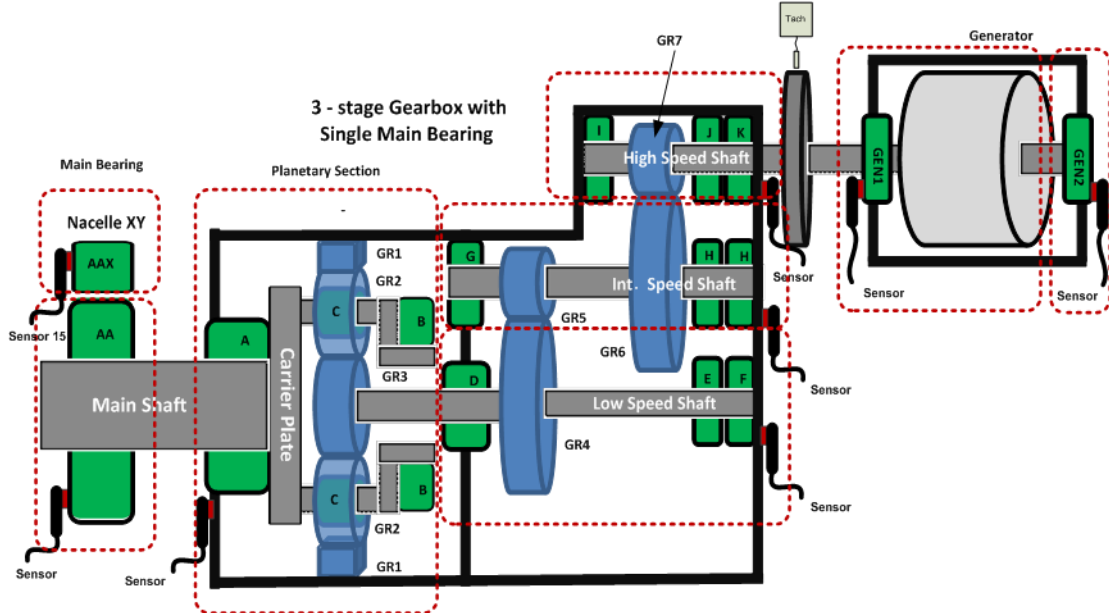

Figure A: Typical Wind Turbine Drivetrain Layout and Sensor Coverage.

Sensor Selection, Configuration, and Mounting

1. Sensor Selection

Not all vibration sensors are the same. Accelerometers are the most commonly applied vibration sensor. However, they have different sensitivity, signal to noise ratio, spectrum range, frequency response, dynamic range, etc. When combined with the proper sensor configuration and algorithm, the sensor should have enough sensitivity and resolution to monitor gear mesh and bearing fault peaks with a high signal-to-noise ratio. For a slow moving section of a wind turbine drivetrain, a low spectrum range, high sensitivity accelerometer should be applied. While in the high-speed section, the spectrum range should be relatively high to cover the bearing fault frequency locations or the resonance band. A vibration condition monitoring sensor system precisely selected for wind applications can provide accurate diagnostics and be cost effective at the same time.

1. Sensor Selection

(continued)

Velocity sensors are also relatively common in the industry. Typically, velocity measurements are utilized to monitor low frequency rotational faults (imbalance, alignment, etc.). Some practices also use velocity to help with bearing fault detection in later failure stages. As modern technology evolves, dynamic range is no longer a limiting factor. Accelerometers are becoming more popular in comparison to velocity transducers. Mathematically speaking, the best velocity transducer is an accelerometer and integrator. Velocity is good for broadband evaluations such as ISO 10816, but not necessary for frequency spectra since it represents a change in the slope of the spectrum.

2. Sensor Configuration

The configuration of the sensor is also crucial and should be tailored to the section of the gearboxes one is monitoring. Normally, for an online retrofitted system, these are preset and can be changed by the condition monitoring system specialist. Each sensor is selected and configured based on the section it is monitoring.

For a handheld system, these settings need to be constrained for the logger to function or to increase the fault detection capability. These configurations need to be changed based on which sections the sensor is collecting data from. The configurations should be logged precisely so that the next time a technician performs testing, they can use the same setup to ensure reading consistency. Common sensor configurations are listed as follows:

- Sampling time
- Sampling duration
- Spectrum resolution or number of spectral lines
- Order tracking
- Frequency range (f_{\max} or low cutoff frequency)
- Band pass filter selection
- Tachometer setting
- With or without averages, number of averages
- Detection method (peak-to-peak, RMS, etc.)

2. Sensor Configuration

(continued)

For handheld systems in general, it is recommended that the acceleration measurement f_{\max} should be higher than three times the focused gear mesh frequency and that the acceleration enveloping f_{\max} should be higher than five times the targeted bearing damage frequency. Data acquisition duration should be long enough to ensure at least 10 to 15 shaft rotations are acquired. Since the number of spectral lines, together with the f_{\max} setting, determine the data acquisition duration, it may be difficult in some cases to satisfy both requirements with a single measurement (data acquisition duration and spectral line resolution).

Note: Signal averaging is not recommended for a variable speed machine. Not only will random noise be reduced, signals related to the speed, such as defect frequencies, will be affected.

3. Sensor Mounting

Ideally, the vibration should be measured for all three axes, including vertical, horizontal, and radial. These measurements can be done if a handheld system is instrumented as long as the monitored locations are consistent from test to test. However, due to cost restraint, only one direction of vibration can be measured in online retrofitted commercial applications. Typically this direction is the radial direction. The tachometer is normally mounted on the high-speed section of the drivetrain, typically between the gearbox downwind side and the generator. The rotating speed of the other shafts of the gearbox can be obtained from the gear ratio.

The sensor mounting location can be different since the turbine and gearbox manufacturer are not always the same. The general guideline is that the sensor should be mounted at, or adjacent to, the loading zone.

Signal Processing

Vibration analysis in simple terms is to detect machine abnormality based on changes in vibration waveform in time domain or frequency domain. Statistics can be extracted from the waveform, such as condition indicators or descriptors. These condition indicators are designed to detect different fault modes of the monitored component.

However, in practice, a proper vibration analysis sequence is quite complicated and includes noise reduction, speed change compensation, fault mode detection algorithm, and fault feature extraction.

1. Noise Reduction and Speed Compensation

Speed compensation and noise cancellation are crucial for a robust and effective condition monitoring system. Noise cancellation is straight forward. Complicated drivetrains, like wind turbines, consistently produce mechanical noises. An effective noise cancellation algorithm can ensure the fault signature is isolated and greatly helps with fault isolation, which greatly reduces the effort for up tower inspection. Speed compensation is also quite critical when it comes to improving signal-to-noise ratio and improving reading consistency.

1.1. Time Synchronous Averaging (TSA)

TSA is designed and developed to detect shaft and gear faults with non-stationary signals that operate in noisy environments, which is ideal for wind applications. To successfully implement TSA, a tachometer reference signal is often necessary. The advantages of implementing TSA are noise reduction and speed compensation. Theoretically, noises or tones that are not synchronous with the target shaft rotating frequency will be greatly reduced. The level of noise reduction correlates with the number of revolutions of the target shaft during the data collection timeframe. TSA can significantly enhance the shaft and gear mesh vibration signature signal-to-noise ratio while coping with speed variation.

1.2. Time Synchronous Re-sampling (TSR)

TSR, like TSA, is used to compensate for speed variation. However, TSR does not average out the non-synchronous vibration signals. This algorithm only re-samples the vibration signal based on tachometer reference. The typical application of TSR is for bearing diagnostics. The implementation of TSR allows the system to sample for a longer period to increase the signal-to-noise ratio and spectrum resolution. This is especially useful when it comes to the slow speed end of the drivetrain, since its rotation takes longer and normally involves quite a bit of speed variation, especially if one samples longer.

2. Fault Mode Detection

2.1. Frequency Domain Analytics

Frequency domain analysis on rotating machineries allows the user to quickly identify potential faults on mechanical components, especially bearings. With each type of bearing fault triggering excitations at a different location of the spectrum, depending on the bearing kinematic, along with modulations on the fault frequency location peaks, frequency domain analysis is one of the most commonly used diagnostics algorithms available. It can also be used for shaft imbalance, misalignment analysis, generator related issues, etc. Fast Fourier transform (FFT) is one of the most commonly used time to frequency domain conversion algorithm. Other similar algorithms that are also explored by vibration analysts include: power density spectrum, Welch's method, and others.

2.2. Time Domain Analytics

Time domain analysis is also one of the most commonly used techniques for vibration analysis on stationary machineries. It is sometimes used for gear fault detection, since non-periodical impact, like damaged gear tooth impact, will not show up in frequency spectrum but will in time domain waveforms. Time domain analysis is also used for rough estimation of overall vibration level for simple systems. Time synchronous averaging is one of the most sophisticated time domain analytical methodologies.

2.3. Time-Frequency Domain Analytics

Time-frequency analysis is quite powerful when it comes to gear analysis. The basic idea is to convert the signal to frequency domain, filter the signals by only looking at a certain area of the spectrum, or remove the undesirable frequency elements. Afterwards, the signal is transformed back to time domain for assessment. This can be especially useful for gear analysis using narrowband, FM, and AM analysis, among others.

3. Fault Feature Extraction

After the signal goes through frequency, time, or time-frequency analysis, a waveform will be extracted from the original signal. These waveforms need to be summarized by statistics so the user can easily assess the waveform by only looking at the key indicators extracted from the waveform.

3. Fault Feature Extraction

(continued)

These indicators are commonly called condition indicators, descriptors, or similar. In simple terms, these are statistics of the processed waveform of some sort. Commonly seen statistics are: root mean square (RMS), mean, median, kurtosis, peak-to-peak (P2P), crest factor (peak over RMS), skewness, and so on and so forth.

Thresholding or Severity Assessment

Currently, there is no established and well recognized standard for the wind turbine drivetrain vibration level assessment. Some references, like ISO 10816, were not specifically developed for wind applications. Standards, such as VDI, are specifically developed for wind application; however, like ISO standards, they are focused on specific bands regardless of the operating condition or load of the turbine. The reason that these stand for vibration severity assessment is that the fundamental frequency of the gear meshing or bearing fault signatures is a function of shaft speed. Even if the band can successfully capture the bearing fault frequency at any operating speed, the drawbacks are inconsistent readings since the operational speed varies and the spectrum will be dominated by gear mesh frequency peaks. These standards also acknowledge that they are only good for general vibration level assessment. For modern CMS, the severity threshold should be set based on the condition indicators calculated by the systems and based on statistics.

While moving the statistics based threshold setting procedures forward, the threshold should be set based on the indicators' distributions. For example, if we set the alarm threshold to be mean plus three sigma, the false alarm rate of a normal distribution can be quite different from that of a Rayleigh or Weibull distribution. Most of the condition indicators, based on publications, are heavily tailed like Rayleigh. Hence, it is crucial to take into account the actual reading distribution when setting the alarm threshold statistically. Always assuming that all of the CI readings are normally distributed will sometimes lead to frequency false alarms, which will lead to the user ignoring the alarms.

Threshold setting is a delicate balance between false alarm and miss detection. Different companies offer different solutions. However, it is recommended to check with the supplier of the thresholding methodology to make sure the alarm setting is effective and robust.

Summary

Vibration analysis techniques have been refined over the years. Vibration based diagnostics for wind applications have their challenges. The speed and load are always fluctuating because of stochastic wind speed and direction. On top of that, the front end of the turbine moves at a relatively slow speed. These issues have a great impact on the vibration based signal processing techniques which are quite different from stationary machines. There have been a series of publications and algorithms developed to cope with these challenges. Further information can be found in the following references if the reader would like to investigate deeper into the algorithmic details or mathematical processing.

References

- [1] AWEA.org. AWEA, "The Cost of Wind Energy in the U.S.," 2017, [Online] Available: www.awea.org/falling-wind-energy-costs. [Accessed].
- [2] J. Zhu, T. Nostrand, C. Spiegel, and B. Morton, "Survey of Condition Indicators for Condition Monitoring Systems," in *Annu. Conf. of the PHMS*, 2014.
- [3] E. Bechhoefer and M. Kingsley, "A review of time synchronous average algorithms," in *Annu. Conf. of the PHMS*, 2009.
- [4] E. Bechhoefer, D. He, and P Dempsey, "Gear health threshold setting based on a probability of false alarm," in *Annu. Conf. of the PHMS*, 2011.
- [5] *Mechanical vibration -- Evaluation of Machine Vibration by Measurements on Non-rotating Parts -- Part 8: Reciprocating Compressor Systems*, ISO 10816 -8:2014, 2014
- [6] *Measurement and Evaluation of the Mechanical Vibration of Wind Turbines and Their Components - Wind Turbines with Gearbox*, VDI 3834 Blatt 1, 2015.
- [7] *Guideline for the Certification of Wind Turbines Edition 2010*, 2010 ed., Germanischer Lloyd, Hamburg, Germany, 2010.

RP 812 Wind Turbine Main Bearing Grease Sampling Procedures

The following recommended practice (RP) is subject to the disclaimer at the front of this manual. It is important that users read the disclaimer before considering adoption of any portion of this recommended practice.

This recommended practice was prepared by a committee of the AWEA Operations and Maintenance (O&M) Committee.

Committee Chairs:

Bruce Hamilton, Navigant Consulting

Jim Turnbull, SKF

Principal Author: Rich Wurzbach, MRG

Contributing Author: Ryan Brewer, Poseidon Systems

Purpose and Scope

The scope of “Wind Turbine Main Bearing Grease Sampling Procedures” discusses the methods for taking uncontaminated and trend-able grease samples from wind turbine main bearings. Samples that are taken properly can provide the user with accurate data for maintenance decision making.

The general procedure applies to wind turbine lubrication systems. There are several different wind turbine main bearing types. This paper will focus on two common main bearing types: those with drain purge plugs and those without. Following methods laid out in ASTM D7718, “*Standard Practice for Obtaining In-Service Samples of Lubricating Grease*”. These recommendations will give proper procedures for the handling of sampling devices and grease before and after samples have been taken to ensure that data obtained from grease analysis is accurate.

Introduction

Performing grease analysis from a specific sampling location is important in ensuring repeatability and accuracy. Unlike oil samples, which can more thoroughly mix and circulate through a gearbox or other location, greases are semi-solids and their flow behavior is quite different. Known as a “non-Newtonian” fluid, their movement and circulation in a bearing is dependent on the grease consistency, temperature, and force applied by nearby moving components, among other factors.

Introduction

(continued)

Published studies demonstrate that greases in wind turbine main bearings do indeed move and circulate, but only in an area very close to the moving parts of the bearing. Therefore, it is critical that any sampling methods provide effective means to obtain grease close to these moving zones or otherwise ensure that grease samples are not compromised by contaminating or diluting influences as they travel away from these flow zones. The methods outlined in this recommended practice provide several approaches to achieve this goal.

Wind Turbine Main Bearing Grease Sampling Procedures

1. Main Bearing Grease Sampling Procedures with Drain Access Plug

NOTE: In this section, “grease sampler” refers to the “passive grease sampling device” described in ASTM D 7718, Section 8. The “T-handle” describes a tool used to reach the grease sampler into the bearing and actuate the sampler at the proper point in the machine. This method ensures that the sample obtained is taken from the area of the bearing where grease circulates due to the action of the bearing.

- 1.1. Place a catch basin below the drain plug to catch any dripping grease.
- 1.2. Remove the drain plug, clean it, and set in a safe place for later re-insertion.
- 1.3. If necessary, remove the grease sampler from packaging used to keep it clean until ready for use. Ensure that the open end of the grease sampler is clear of any cap and that the internal piston is positioned to close off the sampling tube.
- 1.4. Attach the grease sampler piston handle to the T-handle tool by inserting the end of the handle into the internal rod.



Figure A

- 1.5. Insert the internal rod into the pusher tube with the grease sampler facing forward. (See Figure A)

1.6. Thread the base of the grease sampler into the female threads in the pusher tube and make adjustments to set the depth at which the sample will be taken. This should be made based on a measurement or print of the bearing and set such that the fully extended position of the sampler will be very close to, but not touching, the face of the bearing rolling elements.



Figure B

1.7. Position the pusher tube so that the internal piston is flush with the end of the grease sampler. (See *Figure B*)

1.8. Fully insert the grease sampler and T-handle into the drain hole until the positioning guides of the T-handle contact the bearing housing face, positively positioning the grease sampler at the desired set depth.

1.9. Slide the pusher tube forward, while holding the T-handle firmly against the housing face, to core a grease sample close to the bearing.

1.10. When the pusher rod has been slid completely forward, hold it in that position as the T-handle and grease sampler are withdrawn from the housing and access hole.

1.11. Using a clean rag, wipe the excess grease from the T-handle parts and the OUTSIDE of the grease sampler body, being careful not to contact the grease inside.

1.12. Release the internal rod so that it spins freely and un-thread the grease sampler from the pusher tube.

1.13. If there is insufficient grease to sample using the T-handle, utilize a disposable spatula to gather grease from within the drain area and pack into the opened syringe. The syringe is opened by removing the plunger.

The grease selected in this manner should, wherever possible, be taken from the far end of the access hole. If necessary, drag out most of the grease in the hole and set aside to access the grease closest to the moving parts of the bearing.



Figure C

1.14. Additional grease can be put into the grease sampler by reinserting the plunger in the syringe and pushing grease into the grease sampler to achieve maximum fill. (See Figure C)

1.15. The open end of the grease sampler should be secured by placing a cap over the end prior to shipment. It may be necessary to purge a small portion of the grease from the sampler into the cap to avoid an air pocket being pushed into the sampler, displacing some of the sample through the far end of the sampler.

1.16. Once a small portion of the grease is in the cap, slide the cap on the grease sampler just far enough to engage the end of the sampler as a friction fit.

1.17. Place the filled and capped grease sampler into a suitable shipping tube to prevent leakage from the grease sampler and protect it during shipping.

1.18. Affix a sample label on the shipping tube, filling out all necessary information clearly and legibly, including equipment identification, sample date and time, sampler's name, and any notes or observations for the lab. Ensure all samples are clearly identified and promptly submitted to the lab for analysis.

2. Main Bearing Grease Sampling Procedures With Drain Access Plug: Alternative Method

NOTE: This method follows guidance provided in ASTM D7718, Section 10.

2.1. Remove the drain plug and allow any grease near the plug to drain out.

2.2. Using a clean spatula or straw, remove all grease from the inside of the drain area up to a point within about 1" of the moving parts of the bearing. Ensure that in this purging step a sufficient amount of grease remains to obtain the required sample amount.

2.3. Utilize a new, clean spatula or straw to gather grease from that area directly adjacent to the moving bearing parts and pack into an opened syringe. The syringe is opened by removing the plunger. In place of a syringe, a similar suitably clean, closeable container can be used to gather the sample. If the analysis to be performed is a small-volume method as outlined in RP-814, it may be necessary to use the syringe to inject grease into the “passive grease sampling device” described in ASTM D7718. Instructions for properly filling that device are described in the previous section, Steps 1.14 through 1.17.

2.4. Affix a sample label on the sample container, filling out all necessary information clearly and legibly, including equipment identification, sample date and time, sampler’s name, and any notes or observations for the lab.

2.5. Place the sampling container inside the shipping envelope or box and promptly send to the lab for analysis.

3. Main Bearing Grease Sampling Procedures without Drain Access Plug

NOTE: Some bearings do not have a drain access plug or this plug does not provide sufficient access to grease close to the bearing moving parts. In those cases, grease may need to be taken from the face of the bearing, where excess grease is purged in the natural course of the addition of new grease. Samples taken in this manner are much less protected from environmental contaminants, which can skew results. Effort is required to ensure that the influence of these external contaminants are kept to a minimum, and analysis of these samples should consider the potential influence of these factors when making evaluation and recommendations.

3.1. Obtain a disposable spatula or straw that will allow both movement and displacement of external contaminated grease and capturing of the protected underlying grease closer to the exit area. Opposing ends of this straw or spatula can be designated for these two purposes. A syringe or suitable container should be available to place the sampled grease and these sampling devices should be kept clean in protective packaging up to the time of sampling.

3.2. Using a clean rag, wipe the excess grease from the face of the bearing, being careful not to wipe away representative grease just exiting the bearing.

3.3. Select an accessible location on the face of the bearing, close to the bottom of the bearing roller travel, and near the shield gap where excess grease exits the bearing. (See *Figure D*)



Figure D

3.4. Open the protective packaging and remove the disposable spatula/straw and sample container. Using one end of the spatula/straw, wipe away the outermost grease in the area to be sampled to remove ambient dirt and expose underlying recently purged grease.

3.5. Turn the spatula/straw around, utilize the other end to gather grease exiting the bearing face, and pack into the sampling container. If a syringe is used, it is opened by removing the plunger.

3.6. If the analysis to be performed is a small-volume method as outlined in RP-814, it may be necessary to use the syringe to inject grease into the “passive grease sampling device” described in ASTM D7718. Instructions for properly filling that device are described in the first section, Steps 1.14 through 1.17.

3.7. Affix a sample label on the sample container, filling out all necessary information clearly and legibly, including equipment identification, sample date and time, sampler’s name, and any notes or observations for the lab.

3.8. Place the sampling container inside the shipping envelope or box and promptly send to the lab for analysis.

Summary

Proper grease sampling methods are crucial for comparing samples from one turbine to another or for trending samples from the same turbine. If the proper methods are not employed, grease samples can be obtained that do not represent the condition of the bearing wear, contamination levels, or the physical properties of the grease actively involved in lubricating the bearing. Any analysis from such inadequate samples will be misleading and result in improper maintenance actions being taken. Properly obtained samples ensure that analysis results represent current bearing conditions and provide the basis for sound maintenance decisions to provide reliable main bearing operation.

RP 813 Wind Turbine Generator Bearing Grease Sampling Procedures

The following recommended practice (RP) is subject to the disclaimer at the front of this manual. It is important that users read the disclaimer before considering adoption of any portion of this recommended practice.

This recommended practice was prepared by a committee of the AWEA Operations and Maintenance (O&M) Committee.

Committee Chairs:

Bruce Hamilton, Navigant Consulting

Jim Turnbull, SKF

Principal Author: Rich Wurzbach, MRG

Purpose and Scope

The scope of “Wind Turbine Generator Bearing Grease Sampling Procedures” discusses the methods for taking uncontaminated and trend-able grease samples from wind generator bearings. Samples that are taken properly can provide the user with accurate data for maintenance decision making.

The general procedure applies to wind turbine lubrication systems. There are several different manufacturers of generators and each may have a slightly different configuration which could require slight modifications of this procedure. This paper will address one of the more commonly seen configurations in a wind turbine generator: a bearing bottom exit hole and a mating chute to direct purged grease to a catch tray. Following methods laid out in ASTM D7718, “*Standard Practice for Obtaining In-Service Samples of Lubricating Grease*”, these recommendations will give proper procedures for dealing with the chute, gathering grease samples, and the use of sampling devices to ensure that data obtained from grease analysis is accurate.

Introduction

Performing grease analysis from a specific sampling location is important in ensuring repeatability and accuracy. Unlike oil samples, which can more thoroughly mix and circulate through a gearbox or other location, greases are semi-solids and their flow behavior is quite different. Known as a “non-Newtonian” fluid, their movement and circulation in a bearing is dependent on the grease consistency, temperature, and force applied by nearby moving components, among other factors.

Introduction

(continued)

Published studies demonstrate that greases in wind turbine bearings do indeed move and circulate, but only in an area very close to the moving parts of the bearing. Therefore it is critical that any sampling methods provide effective means to obtain grease close to these moving zones or otherwise ensure that grease samples are not compromised by contaminating or diluting influences as they travel away from these flow zones. The methods outlined in this recommended practice provide several approaches to achieve this goal.

Wind Turbine Generator Bearing Grease Sampling Procedures

1. Method 1: Sampling from Bearing Drain Opening with Chute or Deflector

NOTE: In this section, “grease sampler” refers to the “passive grease sampling device” described in ASTM D 7718, Section 8. The “T-handle” describes a tool used to reach the grease sampler into the drain chute or bearing exit slot. This method ensures that the sample obtained is taken from the grease which has most recently exited the bearing. This method references the style of drain chute, shown in Figure A, common to certain Nordex units, with similar chute designs in other units. (See *Figure A*)



Figure A

1.1. Remove the purge container, if so equipped, from the generator bearing grease exit chute, shown by the red arrow in Figure A, and place the container in a clean area.

1.2. Note the condition of the material in the container. If the grease is excessively runny, hard, discolored, or contains shiny or dark particulate, note this on the sampling label.

1.3. Determine if there is sufficient clearance for a T-handle tool or similar sampling tool to insert the tool with a grease sampler into the drain chute. If not, the chute must be removed to obtain the sample.

1.4. If necessary, remove the grease sampler from packaging used to keep it clean until ready for use. Ensure that the open end of the grease sampler is clear of any cap and that the internal piston is positioned to close off the sampling tube.

1.5. Attach the grease sampler piston handle to the T-handle tool by inserting the end of the handle into the internal rod. (See *Figure B*)

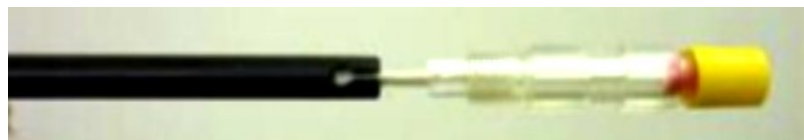

Figure B

1.6. Insert the internal rod into the pusher tube, with the grease sampler facing forward. (See *Figure C*)



Figure C

1.7. Thread the base of the grease sampler into the female threads in the pusher tube and make adjustments to set the depth at which the sample will be taken. Position the T-Handle so that the extended position of the open end of the grease sampler will be inside the bearing housing, adjacent to the area of travel of the bearing within the housing. This is often a few inches longer than the position that would be flush with the surface of the generator housing.



Figure D

1.8. Position the pusher tube so that the internal piston is flush with the end of the grease sampler. By looking up into the chute or bearing drain, verify that there is sufficient accumulation of grease that it presents a solid area of grease for coring. If there is not sufficient grease to permit the coring process described here, go to Method 2 to obtain this sample.

1.9. Insert the grease sampler and T-handle into the chute or bearing drain until the positioning guides of the T-handle contact the outside edge, the chute, or drain hole in the generator housing.

1.10. Slide the pusher tube forward, while holding the T-handle firmly against the purge container lip, to core a grease sample close to the lower entry hole.

1.11. When the pusher rod has been slid completely forward, hold it in that position as the T-handle and grease sampler are withdrawn from the container.

1.12. Using a clean rag, wipe the excess grease from the T-handle parts and the OUTSIDE of the grease sampler body, being careful not to contact the grease inside.

1.13. Release the internal rod so that it spins freely and un-thread the grease sampler from the pusher tube.

1.14. If there is insufficient grease to sample using the T-handle, refer to Method 2 to manually extract grease from the lower entry hole area.

1.15. The open end of the grease sampler should be secured by placing a cap over the end prior to shipment. It may be necessary to purge a small portion of the grease from the sampler into the cap to avoid an air pocket being pushed into the sampler, displacing some of the sample through the far end of the sampler.

1.16. Once a small portion of the grease is in the cap, slide the cap on the grease sampler just far enough to engage the end of the sampler as a friction fit.

1.17. Place the filled and capped grease sampler into a suitable shipping tube to prevent leakage from the grease sampler and protect it during shipping.

1.18. Affix a sample label on the shipping tube, filling out all necessary information clearly and legibly, including equipment identification, sample date and time, sampler's name, and any notes or observations for the lab. Ensure all samples are clearly identified and promptly submitted to the lab for analysis.

2. Method 2: Sampling from Bearing Drain with a Spatula/Straw

NOTE: This method follows guidance provided in ASTM D7718, Section 10. This method assumes that the purge container opening is too small to allow the insertion of a grease sampler inside the container and the grease is to be manually extracted using a disposable spatula.

- 2.1.** Using a clean, lint-free rag, wipe the outside of the grease purge container and surrounding area of the pitch bearing to avoid any of this external contamination from getting into the grease sample to be taken.
- 2.2.** Remove the purge container, if so equipped, from the generator bearing grease exit chute, as shown by the red arrow in Figure A, and place the container in a clean area.
- 2.3.** Inspect the exit chute or drain opening in the bearing to determine if there is sufficient grease accessible in this area for the required sample size.
- 2.4.** Using a clean spatula or straw, remove grease from the inside of the drain area up to a point within about 1" of the moving parts of the bearing, if possible. In this purging step, ensure that a sufficient amount of grease remains to obtain the required sample amount.
- 2.5.** Utilize a new, clean spatula or straw to gather grease from that area directly adjacent to the moving bearing parts and pack into an opened syringe. The syringe is opened by removing the plunger. In place of a syringe, a similar suitably clean, closeable container can be used to gather the sample. If the analysis to be performed is a small-volume method as outlined in RP-814, it may be necessary to use the syringe to inject grease into the "passive grease sampling device" described in ASTM D7718.



Figure E

2.6. Additional grease can be put into the grease sampler by reinserting the plunger in the syringe and pushing grease into the grease sampler to achieve maximum fill.

2.7. If there is insufficient grease in the drain path to fill the grease sampler, the remaining amount can be obtained from the chute at the end closest to the bearing or from the purge container. The grease closest to the opening is the most recently purged grease and the most representative of the current condition of the bearing. If a sample is obtained from these alternate areas, note this on the sample label so the analyst can take this into consideration.

2.8. The open end of the grease sampler should be secured by placing a cap over the end prior to shipment. It may be necessary to purge a small portion of the grease from the sampler into the cap to avoid an air pocket being pushed into the sampler, displacing some of the sample through the far end of the sampler.

2.9. Once a small portion of the grease is in the cap, slide the cap on the grease sampler just far enough to engage the end of the sampler as a friction fit.

2.10. Place the filled and capped grease sampler into a suitable shipping tube to prevent leakage from the grease sampler and protect it during shipping.

2.11. Affix a sample label on the sample container, filling out all necessary information clearly and legibly, including equipment identification, sample date and time, sampler's name, and any notes or observations for the lab.

2.12. Place the sampling container inside the shipping envelope or box and promptly send to the lab for analysis.

Summary

Proper grease sampling methods are crucial for comparing samples from one turbine to another or for trending samples from the same turbine. If the proper methods are not employed, grease samples can be obtained that do not represent the condition of the bearing wear, contamination levels, or the physical properties of the grease actively involved in lubricating the bearing. Any analysis from such inadequate samples will be misleading and result in improper maintenance actions being taken. Properly obtained samples ensure that analysis results represent current bearing conditions and provide the basis for sound maintenance decisions to provide reliable generator operation.

RP 814 Wind Turbine Pitch Bearing Grease Sampling Procedures

The following recommended practice (RP) is subject to the disclaimer at the front of this manual. It is important that users read the disclaimer before considering adoption of any portion of this recommended practice.

This recommended practice was prepared by a committee of the AWEA Operations and Maintenance (O&M) Committee.

Committee Chairs:

Kevin Dinwiddie, AMSOIL

Erik Smith, Moventas

Bruce Hamilton, Navigant Consulting

Principal Author: Benjamin Karlson, Sandia National Laboratories

Purpose and Scope

The scope of “Wind Turbine Pitch Bearing Grease Sampling Procedures” discusses the methods for taking uncontaminated and trend-able grease samples from wind turbine pitch (blade) bearings. Samples that are taken properly can provide the user with accurate data for maintenance decision making.

The general procedure applies to wind turbine lubrication systems. There are several different wind turbine pitch bearing styles and purge recovery systems. This paper will address two such pitch bearing purge recovery styles and can apply to both automatic and manual grease lubrication systems. Following methods laid out in ASTM D7718, “*Standard Practice for Obtaining In-Service Samples of Lubricating Grease*”, these recommendations will give proper procedures for the handling of purge recovery containers, sampling devices, and grease before and after samples have been taken to ensure that data obtained from grease analysis is accurate.

Introduction

Performing grease analysis from a specific sampling location is important in ensuring repeatability and accuracy. Unlike oil samples, which can more thoroughly mix and circulate through a gearbox or other location, greases are semi-solids and their flow behavior is quite different. Known as a “non-Newtonian” fluid, their movement and circulation in a bearing is dependent on the grease consistency, temperature, and force applied by nearby moving components, among other factors.

Introduction

(continued)

Published studies demonstrate that greases in wind turbine bearings do indeed move and circulate, but only in an area very close to the moving parts of the bearing. Therefore, it is critical that any sampling methods provide effective means to obtain grease close to these moving zones or otherwise ensure that grease samples are not compromised by contaminating or diluting influences as they travel away from these flow zones. The methods outlined in this recommended practice provide several approaches to achieve this goal.

Wind Turbine Pitch Bearing Grease Sampling Procedures

1. Method 1: Recovery from Purge Container with Removable Lid

NOTE: In this section, “grease sampler” refers to the “passive grease sampling device” described in ASTM D 7718, Section 8. The “T-handle” describes a tool used to reach the grease sampler into the purge container. This method ensures that the sample obtained is taken from the grease which has most recently exited the bearing. This method references the style of purge container shown in Figure A, common to certain Vestas units.



Figure A

1.1. Remove the purge container from the blade bearing and place the container on a level surface with the removable lid facing up.

1.2. Remove the lid and set aside.

1.3. Verify that there is sufficient accumulation of grease that presents a solid glob adjacent to the lower entry hole and is larger than the length of the grease sampler. If there is not sufficient grease to permit the coring process described here, go to Method 2 to obtain this sample.

1.4. If necessary, remove the grease sampler from packaging used to keep it clean until ready for use. Ensure that the open end of the grease sampler is clear of any cap and that the internal piston is positioned to close off the sampling tube.

1.5. Attach the grease sampler piston handle to the T-handle tool by inserting the end of the handle into the internal rod. (See *Figure B*)



Figure B

1.6. Insert the internal rod into the pusher tube, with the grease sampler facing forward. (See *Figure C*)



Figure C

1.7. Thread the base of the grease sampler into the female threads in the pusher tube and make adjustments to set the depth at which the sample will be taken. Position the T-handle so that the extended position of the open end of the grease sampler will be slightly past the lower entry hole in the side of the container. (See *Figure D*)



Figure D

- 1.8.** Position the pusher tube so that the internal piston is flush with the end of the grease sampler.
- 1.9.** Insert the grease sampler and T-handle into the top of the purge container, keeping close to the wall where the entry holes are located, until the positioning guides of the T-handle contact the top lip of the container, positioning the grease sampler at the lower entry hole.
- 1.10.** Slide the pusher tube forward, while holding the T-handle firmly against the purge container lip, to core a grease sample close to the lower entry hole.
- 1.11.** When the pusher rod has been slid completely forward, hold it in that position as the T-handle and grease sampler are withdrawn from the container.
- 1.12.** Using a clean rag, wipe the excess grease from the T-handle parts and the OUTSIDE of the grease sampler body, being careful not to contact the grease inside.
- 1.13.** Release the internal rod so that it spins freely, and un-thread the grease sampler from the pusher tube.
- 1.14.** If there is insufficient grease to sample using the T-handle, refer to Method 2 to manually extract grease from the lower entry hole area.
- 1.15.** The open end of the grease sampler should be secured by placing a cap over the end prior to shipment. It may be necessary to purge a small portion of the grease from the sampler into the cap to avoid an air pocket being pushed into the sampler, displacing some of the sample through the far end of the sampler.
- 1.16.** Once a small portion of the grease is in the cap, slide the cap on the grease sampler just far enough to engage the end of the sampler as a friction fit.
- 1.17.** Place the filled and capped grease sampler into a suitable shipping tube to prevent leakage from the grease sampler and protect it during shipping.
- 1.18.** Affix a sample label on the shipping tube, filling out all necessary information clearly and legibly, including equipment identification, sample date and time, sampler's name, and any notes or observations for the lab. Ensure all samples are clearly identified and promptly submitted to the lab for analysis.

2. Method 2: Recovery from Purge Container without a Lid

NOTE: This method follows guidance provided in ASTM D7718, Section 10. This method assumes that the purge container opening is too small to allow the insertion of a grease sampler inside the container and that the grease is to be manually extracted using a disposable spatula.

2.1. Using a clean, lint-free rag, wipe the outside of the grease purge container and surrounding area of the pitch bearing to avoid any of the external contamination from getting into the grease sample to be taken.

2.2. Remove the purge container, as shown in Figure E, from the pitch bearing and set on a level surface with the open end facing up. Other styles of purge container can also be used in this manner.

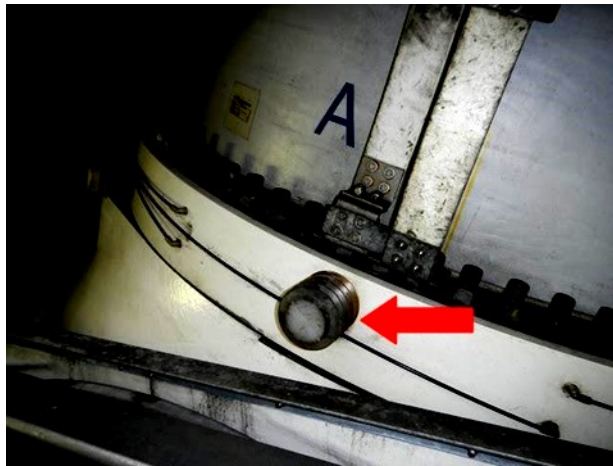

Figure E

2.3. Inspect the exit hole in the bearing to determine if there is sufficient grease accessible in this area for the required sample size.

2.4. Using a clean spatula or straw, remove grease from the inside of the drain area up to a point within about 1" of the moving parts of the bearing, if possible. Ensure that in this purging step, a sufficient amount of grease remains to obtain the required sample amount.

2.5. Utilize a new, clean spatula or straw to gather grease from that area directly adjacent to the moving bearing parts and pack the grease into an opened syringe. The syringe is opened by removing the plunger. In place of a syringe, a similar suitably clean, closeable container can be used to gather the sample. If the analysis to be performed is a small-volume method as outlined in RP-814, it may be necessary to use the syringe to inject grease into the "passive grease sampling device" described in ASTM D7718.



Figure F

2.6. Additional grease can be put into the grease sampler by re-inserting the plunger in the syringe and pushing grease into the grease sampler to achieve maximum fill.

2.7. If there is insufficient grease in the drain path to fill the grease sampler, the remaining amount can be obtained from the area near the opening inside the purge container. The grease closest to the opening is the most recently purged grease and the most representative of the current condition of the bearing.

2.8. The open end of the grease sampler should be secured by placing a cap over the end prior to shipment. It may be necessary to purge a small portion of the grease from the sampler into the cap to avoid an air pocket being pushed into the sampler, displacing some of the sample through the far end of the sampler.

2.9. Once a small portion of the grease is in the cap, slide the cap on the grease sampler just far enough to engage the end of the sampler as a friction fit.

2.10. Place the filled and capped grease sampler into a suitable shipping tube to prevent leakage from the grease sampler and protect it during shipping.

2.11. Affix a sample label on the sample container, filling out all necessary information clearly and legibly, including equipment identification, sample date and time, sampler's name, and any notes or observations for the lab.

2.12. Place the sampling container inside the shipping envelope or box and promptly send to the lab for analysis.

Summary

Proper grease sampling methods are crucial for comparing samples from one turbine to another or for trending samples from the same turbine. If the proper methods are not employed, grease samples can be obtained that do not represent the condition of the bearing wear, contamination levels, or the physical properties of the grease actively involved in lubricating the bearing. Any analysis from such inadequate samples will be misleading and result in improper maintenance actions being taken. Properly obtained samples ensure that analysis results represent current bearing conditions and provide the basis for sound maintenance decisions to provide reliable pitch bearing operation.

RP 815 Wind Turbine Grease Analysis Test Methods

The following recommended practice (RP) is subject to the disclaimer at the front of this manual. It is important that users read the disclaimer before considering adoption of any portion of this recommended practice.

This recommended practice was prepared by a committee of the AWEA Operations and Maintenance (O&M) Committee.

Committee Chairs:

Bruce Hamilton, Navigant Consulting

Jim Turnbull, SKF

Principal Author: Rich Wurzbach, MRG

Contributing Author: Ryan Brewer, Poseidon Consulting

Purpose and Scope

The scope of “Wind Turbine Grease Analysis Test Methods” will focus on specific test methods which should be applied for accurate grease testing and analysis.

Introduction

Accurate grease analysis results are critical to the successful diagnosis of wear rates, contamination levels, oxidation levels, and consistency of the grease. Inaccuracies can be due to improper test methods selected for the particular application, inadequate quality control of test methods, or poor sampling techniques. This practice is intended to assist in proper test selection specific to wind turbine grease samples, thus allowing for proper diagnosis and reasonable corrective action based on sound limits and warnings.

Test methods specific to wind turbine main bearing grease should provide accurate oil test results on which to base good maintenance decisions and reduce operating costs. Effectiveness of grease analysis test methods is directly and completely dependent on the accuracy of the samples obtained for this purpose. Consult AWEA guidance on grease sampling methods, developed in compliance with ASTM D7718, “*Standard Practice for Obtaining In-Service Samples of Lubricating Grease*”.

Wind Turbine Grease Analysis Test Methods

1. Procedures

Prior to sending grease samples to your laboratory, it is important to establish with your laboratory which tests are to be performed on the used in-service grease, the grease volume needed to run these tests, and the condemning limits that should be applied. Some methods exist that enable an in-service grease analysis basic test slate including measurement of wear, consistency, contamination, and oxidation with as little as 1 gram of grease. Some tests require greater quantities of grease. In all cases, the grease submitted for sampling must be representative of the condition of the grease actively lubricating the bearing and receiving wear particles by nature of proximity to the wearing surfaces.

2. Grease Analysis Methods

OEMs may require grease analysis more often during initial startup on new turbines. Grease analysis can be performed every 6 months or annually, depending on component age, history, or other factors. Typically, samples can be taken while up tower performing other routine maintenance tasks. A typical test slate for grease analysis may include the following tests (methods listed in this section are recommended for use with wind turbine grease):

- Ferrous debris quantification*
- Consistency testing, such as cone penetration, rheometry, or die extrusion test*
- Infrared spectroscopy (FTIR)
- Anti-oxidant additive quantification, such as linear sweep voltammetry (ASTM D7527) or short-path FTIR
- Elemental spectroscopy, such as RDE or ICP
- Visible appearance (manually or grease colorimetry*)
- Water PPM (D6304, oven method)

NOTE: Those tests marked with asterisk (*) are a pending ASTM work practice in review for ASTM standard in CS96 committee as of the writing of this procedure.

2.1. Ferrous Debris Quantification

This test determines the amount of ferromagnetic material present in the sample. Because the metallurgy of wind turbine drivetrain components are primarily ferrous, this test is effective at monitoring ferrous wear debris generation rate. Several methods exist that measure the change in voltage as it is dropped through an electromagnetic field. The Hall effect refers to the voltage induced in a conductor in the presence of magnetic flux. One method must be selected and applied consistently, as there are differences in values produced by different ferrous debris monitoring technologies.

The values derived from such analyses are used as a general flagging mechanism for the lab to detect high wear levels. An action level should be developed based on the method used and statistical analysis or evaluation of historical values against observed conditions. When the sample has exceeded the action level, analytical ferrography is recommended to characterize the nature and severity of the wear. It should be noted that wear debris in grease is cumulative until flushed out by introduction of new grease and that replenishment rate must be factored into the development of action criteria.

2.2. Consistency Test

The consistency of grease is a function of the base oil and thickener and their types and ratios. The consistency is important in ensuring that the grease will stay in place in the intended lubrication point and affects the ability of the grease matrix to supply liquid oil to maintain a lubricant film to separate surfaces in relative motion. After some time in service, the consistency can change due to variables such as grease mixing, aging, overheating, excessive working, or contamination. In new grease, consistency is measured by cone penetration and an NLGI number is assigned to the grease on a scale from 000 to 6. In-service greases usually cannot be tested per the cone penetration method due to the large quantities required, so the rheometer or die extrusion methods are typically used.

In die extrusion, the consistency is determined by measuring the load required to force the grease through an orifice of known dimensions at varying speeds. The consistency of the grease is compared to the new baseline grease. Drastic increases or decreases in the consistency correspond to severe thickening or thinning of the grease, which could indicate abnormal operating conditions and/or compromise reliability.

2.2. Consistency Test

(continued)

For rheometry, the grease is placed between opposing plates that are rotated and oscillated while measuring the resulting force, which is a function of the consistency and flow characteristics of the grease. Parameters measured include storage modulus (grease flow), oscillation stress (oil content and shear from thickener), and recoverable compliance (tendency to tunnel or channel in the bearing or gearbox).

In either test, results are compared to new, fresh grease, and criteria is developed to flag samples that deviate significantly in service from the new grease. Due to the geometry and loads in wind turbine main bearings, consistency reductions of as much as 40-50% may be considered typical for in-service greases and it is necessary to establish action criteria based on statistical analysis or comparative operating histories.

2.3. FTIR Infrared Spectroscopy

Infrared (IR) spectroscopy or Fourier transform infrared spectroscopy (FTIR) have been used for many years to provide rapid, low cost, offline analyses of oil samples. The technology passes an infrared light source through a lubricant sample to an infrared detector. The light that passes through the oil is influenced by the fluid properties as oil contaminants and additives absorb infrared radiation at varying frequencies. By comparing the frequency spectrum of new and used oil samples it is possible to determine the lubricant properties, such as water, soot, oxidation, nitration, and glycol levels.

Through advances in electronics manufacturing techniques, IR technology is beginning to make its way into online sensing devices. Current technology does not have the refined measurement capabilities of laboratory devices. However, they do offer multi-parameter trending capabilities which can provide valuable, real-time insight into fluid condition.

FTIR is used to fingerprint the molecular bonds in the grease. An IR beam is passed through a thin grease film, of known dimension, and the resulting absorbance spectrum is used to characterize the organic components of the grease. Alternatively, other sample introduction methods can be used, such as attenuated total reflectance (ATR) or photoacoustic spectroscopy. By comparing the in-service sample to the baseline, oxidation, grease mixing, and organic contamination, including water, can be detected.

2.4. Linear Sweep Voltammetry

Linear sweep voltammetry, known commercially as “RULER”, measures the remaining useful life of the anti-oxidant additive package. A voltage sweep is applied to the sample as the current is measured. The graph of current and time will contain peaks which correspond to different anti-oxidants, and the concentration remaining in the sample is proportional to the area under the curve for these peaks. The results are reported as a percentage of the concentration found in the baseline grease.

2.5. Atomic Emission Spectroscopy

The quantification of metallic elements in grease can be accomplished by rotating disc electrode (RDE), inductively coupled plasma (ICP), or x-ray fluorescence (XRF). While atomic emission spectroscopy is routine for oil analysis, sample preparation is unique for greases. The grease must either be dissolved by a clean, filtered solvent and analyzed, or use a uniform preparation method to introduce the solid grease to the analyzer. For ICP, the sample must be fully dissolved. The selection of the solvent system for each grease type is important to the effectiveness of the method. ASTM D7303 governs the ICP method. For the XRF and RDE methods, direct application, without dissolving sample, preparation methods are used in industry and standards are under development.

For the solvent methods, the grease is dissolved in reagent grade organic solvent and vaporized in the sample chamber. The atoms are excited with an electric arc and the light patterns emitted are compared with the known patterns of 19 different metals. The spectrometer detects most wear particles such as iron and Babbitt, as well as certain additive elements that could indicate grease mixing. All results are recorded in parts per million (ppm). The limitation of this technology is the instrument is not sensitive to particles larger than about 6 microns because they do not vaporize in the AC arc.

2.6. Grease Colorimetry

Grease colorimetry measures light absorbance in the visible light range (400 nm to 700 nm) under controlled repeatable conditions. The resulting spectrum has peaks which differentiate colors at a much higher sensitivity than the human eye. Because some grease products contain unique dyes, this method can be used to detect grease mixing when the true baseline is known.

2.6. Grease Colorimetry

(continued)

This method can validate observed appearance changes in greases, trend darkening due to aging or overheating, characterize dye formulations of new grease, and approximate the concentration of certain particulate contaminants, such as coal dust, soot, or other solids accumulating in the grease. As an alternative method, subjective visual analysis of the grease and comparison to the appearance of new or typical used greases can be made.

2.7. Water PPM

The presence of moisture in lubricating greases leads to corrosion, wear, and an increase in debris load which contributes to bearing and gear fatigue. While FTIR can identify gross levels of water in greases, it is typically not accurate in assessing quantitative values.

A quantitative test is the Karl Fischer titration by oven method, ASTM D6304. This test method detects the presence of water by thermal mass transfer of the grease to a dry gas, which is then titrated to determine parts per million of water in the grease. Action criteria can be determined from statistical analysis of a given population of similar wind turbine drivetrain components in a certain environmental application or comparative operating histories.

3. Interpreting Grease Analysis Results

3.1. Consult your specific laboratory for help with interpreting results and understanding the lab reports.

3.2. Appropriate alarms (min./max., percent change, deviation) will vary based on machine and population of sample data.

3.3. Any opportunity to evaluate and inspect a removed wind turbine drivetrain component should be made to correlate as-found conditions to the preceding grease analysis trends and expand the knowledge base for developing more precise and accurate action criteria.

Summary

A comprehensive, disciplined approach to grease sample collection, specific analysis methods, trend monitoring, and proper condemning limits can help identify grease, bearing, and gear issues. This enables wind farm operators to make cost-effective servicing and maintenance decisions and predict bearing and gear failures so that pre-emptive action can be taken. Overall, the objective supported by this recommended practice is to accumulate solid data in order to reduce guesswork, improve uptime and availability, and ultimately to reduce O&M costs.

RP 816 Wind Turbine Temperature Measurement Procedures

The following recommended practice (RP) is subject to the disclaimer at the front of this manual. It is important that users read the disclaimer before considering adoption of any portion of this recommended practice.

This recommended practice was prepared by a committee of the AWEA Operations and Maintenance (O&M) Committee.

Committee Chairs:

Bruce Hamilton, Navigant Consulting

Jim Turnbull, SKF

Principal Author: Eric Bechhoefer, NRG System

Purpose and Scope

The scope of “Wind Turbine Temperature Measurement Procedures” discusses the methods and procedures to facilitate temperature based condition monitoring. Temperature is available from most supervisory control and data acquisition systems (SCADA) and provides a low cost, late warning indicator for bearing, generators, and motor components in the turbine.

Introduction

Temperature is an age old indicator of component health. Bearing manufacturers have long been aware of the relationship between bearing temperature and bearing life. Because of this relationship, temperature can be used to monitor bearing condition or for other temperature sensitive components, such as motors and generators.

If temperature is a reliable method for component life prediction, why is its use not cited more often as an indicator of fault? While there are subtle changes in temperature due to wear, there are many other environmental factors that affect bearing temperatures, such as load, speed, and ambient temperature.

The key to successfully use temperature for component life prediction is to remove the environmental factors so that differences in temperature between the same components on similar turbines reflect actual bearing faults or other component faults where temperature can signify failures.

Introduction

(continued)

Potential areas where temperature can be used for condition monitoring include, but is not limited to:

- Main bearing
- Generator bearings
- Generator windings
- Gearbox oil sump
- Gearbox bearings
- Yaw motors
- Pitch motors
- Slip ring
- Hydraulic pumps

Temperature Condition Monitoring Procedures

In general, the temperature sensor must be attached in close proximity to the bearing/component under analysis.

1. Simple Troubleshooting Rules for Bearings

The temperature should be no more than 82°C on the bearing housing. The bearing outer ring can be up to 11°C hotter than the housing. Note that lubricants are typically selected to run at lower temperatures and a temperature rise of 28°C may cause oil viscosity to drop by 50% or more.

2. Simple Troubleshooting Rules for Electric Motors and Generators

The National Electrical Manufacturers Association (NEMA) has defined temperature rise for electric motors and generators in MG 1-1998. This standard outlines the normal maximum temperature rise based on a maximum ambient temperature of 40°C, power/load, service factor rating, and insulation class. For example, for a 1.5 MW generator with a service factor of 1.15 and insulation class B, the maximum allowable temperature rise would be 95°C. Thus, the machine should alert a warning condition when the winding temperature is greater than 135°C.

3. The Use of SCADA for Temperature Condition Monitoring

SCADA systems can be used to alert for high temperature conditions on bearings, generators, and motors. As noted, successful temperature diagnostics requires reducing the effect of environmental factors.

3.1. Define a component temperature rise (CTR), which is the difference of the sensor temperature and ambient temperature.

3.2. Define a threshold for CTR. Since the operating temperature can be a function of load/power output, consider developing threshold bins by wind speed/power output to reduce variation. Additionally, threshold should be set for similar machine configuration, e.g. the combination of model, gearbox, and generator represent one type of machine configuration.

3.2.1. Use a minimum of 6 nominal machines, with a minimum of 21 acquisitions per machine, to generate test statistics (mean and standard deviation).

3.2.2. Assuming near Gaussian distributions, set the threshold for each power bin as CTR mean + 3*CTR standard deviation, which will give an approximate probability of false of 1e-3.

3.3. Set alarm alerts for hot bearings at 82°C.

3.4. Set generator/motor alerts based on NEMA MG 1-1998, as appropriate.

Summary

Temperature can be a powerful indicator of component health. That said, temperature of components is also affected by environmental factors such as ambient temperature, load, and speed. By reducing the effect of these environmental factors (monitoring temperature rise, binning by power), temperature can be used to diagnose component wear. For bearings, the absolute temperature should not exceed 82°C. For motors/generators, NEMA MG 1-1998 should be consulted for absolute temperature limits.

RP 817 Wind Turbine Nacelle Process Parameter Monitoring

The following recommended practice (RP) is subject to the disclaimer at the front of this manual. It is important that users read the disclaimer before considering adoption of any portion of this recommended practice.

This recommended practice was prepared by a committee of the AWEA Operations and Maintenance (O&M) Committee.

Committee Chairs:

Bruce Hamilton, Navigant Consulting

Jim Turnbull, SKF

Principal Author: Dan Doan, GE Energy

Purpose and Scope

The scope of “Wind Turbine Nacelle Process Parameter Monitoring” discusses the methods and procedures to facilitate nacelle process parameter modeling for condition based monitoring. The process parameters are available from the OEM controls system (SCADA) and provides an early warning indicator for degraded operation of bearings, gearboxes, blade controls, generators, motors, and control components in the turbine.

Introduction

There are many methods with which to monitor and utilize the supervisory control and data acquisition systems (SCADA) data collected around the processes within a wind turbine and wind plant. The issue is the high variability in the data and getting a sense of the data compared to the plant and historical operations. One proven method is using empirical non-parametric modeling of process parameters to complement traditional condition based maintenance techniques. The process parameters provide drivers and responses for modeling methodologies to detect “normalized” departures from historical behavior that could be early indicators of degraded conditions around the equipment in the Nacelle.

The industry description of this methodology is referred to as advanced pattern recognition (APR) and has been used successfully in the wind industry over all manufacturers and designs of wind turbine generators. The understating of relationships between performance and mechanical systems has been known since the origins of condition based maintenance. When a bearing temperature increases, the technician looks at trends in the data for the variable of concern: local ambient temperatures, oil supply temperatures, speed of the rotating system, load changes, cooling system operations, etc. These correlations were, and are, performed manually, by some simple data extractions and X/Y plots, or simply by visual comparison of trends against the one in question.

Introduction

(continued)

This “validation” is performed in relationship to hard alarms. With little or no warning, hard alarms placed the technician at disadvantage, having to react to the equipment alarm conditions. By the end of the 1990s, computer hardware and software systems had advanced sufficiently in order to perform statistical modeling using stand-alone computer systems. The advanced pattern recognition algorithms were commercialized to take advantage of “online data mining”, that is, running advanced statistical models in real-time on process parameters.

The key to successfully using process parameters in condition based maintenance is ensuring that there is a known, good historical reference data set to use for comparison with current process parameters.

The APR methodologies are very robust and accurate in determining the behavior of an asset. They are very sensitive to changes in single instrument behavior that are clear indicators of degradation, i.e. small deviation in bearing metal temperature (<10% of normal span of operation) while taking into many other environmental factors affecting the bearing temperature, such as load, speed, and ambient temperature.

Statistical models are used to compare the same components, for similar assets across a wind plant, detecting changes in the components behavior as compared to the other assets. This analysis, which can be automated, identifies the outliers and focuses resources where and when they are needed.

Areas where statistical models and APR can be used for condition monitoring include, but are not limited to the following asset components:

- Hub system
 - Main bearing
 - Blades
- Gearbox
 - Bearings
 - Oil sump
 - Gears
 - Oil system
 - Online oil particulates
 - Oil cooler
- Generator
 - Bearings
 - Windings
 - Slip rings
 - Controls
 - Cooling systems

Introduction

(continued)

Asset components list continued:

- Transformers
- Converters
- Yaw
 - Controls
 - Position
- Wind
 - Power
 - Efficiency
 - Direction
 - Speed

The different assets include all physical measurements and calculations associated with these assets:

- Pressures
- Temperatures
- Vibrations, including deterministic characteristic: kurtosis, crest factor, spike energy, stress wave, etc.
- Voltage
- Current
- Torque
- Strain
- Moment
- Particle count
- Wind direction
- Wind speed
- Wind deviation
- Blade tip speed ratio
- Ambient temperatures
- Ambient pressures
- Power
- Position
- Set points
- Control demand signals
- Etc.

The more parameters around a component the better the detection of potential effects from degradation.

Fleet comparison of parameters for a component, e.g. localized models looking at all similar gearbox parameters, typically takes the form of a correlation matrix or statistical modeling.

Advance Pattern Recognition and Statistical Analysis Condition Monitoring Procedures

In general, the greater the number of parameters monitoring a process, the better the modeling. For most APR models there needs to be, at a minimum, three (3) drivers (independent parameters): ambient temperature, rotor speed, and power output and five (5) or more response (dependent parameters): bearing vibration, bearing temperatures, oil temperatures, etc. Typically the OEM installed sensors are enough to get started. A rule of thumb is that the more sensors around a process, the better the detection of an abnormal behavior.

1. Where Advance Pattern Recognition (APR) Fits into Condition Monitoring for Wind Turbines

APR is an “early” detection methodology for changes in equipment asset behavior using statistical techniques. They are typically early warning systems that gives time for the analyst to run fleet comparisons and analyze the behavior. With early detection there is some ambiguity in the actionability of the advisories that APR systems report.

These systems have low false reporting rates as compared to standard alarming systems since they use models based on each turbines unique historical behavior to determine when there has been a change that needs investigating.

APR systems increase the coverage for failure modes and effects analysis beyond traditional predictive maintenance techniques. APR correlates all the behaviors, which results in early notification in equipment degradation without having to deploy resources in the field. This helps optimize time based predictive maintenance and preventive maintenance work for up tower activities.

2. How Statistical Models Fit into Condition Monitoring for Wind Turbines

Most wind plants have many “identical” turbines in a similar environment with the same operating profile. This enhances the ability to compare like assets across a large population. Statistical models are used to compare the behavior of each asset’s parameters on a wind turbine to the local populations of the wind plant’s similar wind turbines’ parameters. This allows for detection of an outlier on one turbine in comparison to the local population of wind turbines and classifies the severity of the change in behavior.

In addition, the power profile for one turbine is compared to the plant, and degraded performance is classified and compared to the overall plant performance, which could identify control system degradation or equipment degradation that would be missed in monitoring a turbine in isolation.

3. The Use of SCADA for Time Series Data Trending and Analysis

SCADA systems can be used to provide data for all the parameters measured within the nacelle. Successful diagnostics requires eliminating the effects of operational and environmental influences. This is accomplished by statistical/APR modeling and asset model comparisons across the wind plant.

3.1. Since statistical and APR models are based on empirical data, the range of operation of the parameters is used to set the actionability of a change in behavior.

3.2. Define a threshold for APR. Since the operating parameters can be a function of load/power output, engineering and technical understanding of the normal behavior of each asset is used to set the threshold criteria. Some of the APR and statistical products allow a service threshold to be set for similar machine configurations, e.g. the combination of a motor, gearbox, and generator represent one type of machine configuration.

3.2.1. To build the thresholds, the user will use engineering judgement on how far from the normal range of operations that the modeled parameter can be for abnormal behavior. This can be done statistically or with engineering first principle knowledge of the wind turbines:

For example, consider a five (5) degree difference between the actual value and the statistical normal behavior (modeled) for the metal bearing temperature of a high-speed bearing on the generator that is operating well below its OEM recommended temperature. Since the model takes into account all “known” behavior, this is an abnormal behavior that could be indicative of low oil level in the bearing cavity.

3.2.2. Suppliers of the different statistical and APR technologies have specific methodologies to determine the thresholds for each asset within a nacelle.

3.3. Alarm alerts are determined by the model, thresholds, and persistence.

3.4. To date, there are no industry standards for setting advisory notifications.

Summary

SCADA statistical models and APR models are the best solutions of process parameters modeling for determining component health. Since these methods remove the normal behavior and emphasize the abnormal behavior across the process parameters associated with the assets within the nacelle (self-normalizing), these solutions focus attention to actual changes in behavior that are an early indicator of a possible failure mode.

Care should be taken that the modeled behavior does not allow a parameter to exceed the OEM, best practices, or thresholds that have been established to protect the equipment and for personnel safety.

Statistical and APR theories have been around for approximately one hundred years. Since the late 1990s, the hardware and software in the industrial networks have evolved to a point where development and deployment of these solutions on real-time data feeds is acceptable. They are used extensively in the power industries, oil and gas, and mining. In the power sector, they are deployed on many thousands of wind turbines throughout the world.

References

- [1] R. Shankar, "Fleetwide Monitoring for Equipment Condition Assessment," EPRI, Harriman, Tennessee, USA, Rep. 1010266, 2006.

RP 818 Wind Turbine On-Line Gearbox Debris Condition Monitoring

The following recommended practice (RP) is subject to the disclaimer at the front of this manual. It is important that users read the disclaimer before considering adoption of any portion of this recommended practice.

This recommended practice was prepared by a committee of the AWEA Operations and Maintenance (O&M) Committee.

Committee Chairs:

Kevin Dinwiddie, AMSOIL

Erik Smith, Moventas

Bruce Hamilton, Navigant Consulting

Principal Author: Andrew German, GasTOPS

Purpose and Scope

The scope of “Wind Turbine On-Line Gearbox Debris Condition Monitoring” discusses the use of oil debris monitoring to assess and monitor the health of a wind turbine gearbox as part of a comprehensive condition monitoring program.

Experience has shown that premature gearbox failures are a leading maintenance cost driver of a wind turbine operation. Premature gearbox failures reduce turbine availability, result in lost production and downtime, and can add significantly to project lifecycle cost of operation.

Oil debris monitoring used in conjunction with prognostics and health management (PHM) techniques offers the potential of detecting early gearbox damage, tracking the severity of such damage, estimating the time to reach pre-defined damage limits, and providing key information for proactive maintenance decisions. Experience has shown that major damage modes in wind turbine gearboxes are typically bearing spall and gear teeth pitting, both of which release metallic debris particles into the oil lubrication system^[1-3]. Oil debris monitoring is well suited to provide an early indication and quantification of surface damage to bearings and gears of a wind turbine gearbox.

An oil debris sensor is used to detect and count metallic debris particles in the lube oil as it flows through the bore of the sensor. The amount of debris detected and the trend in particle counts can be used as an indication of component wear and damage. These sensors may employ inductive coils to detect debris resulting from early gearbox damage and are capable of detecting both ferromagnetic and non-ferromagnetic metallic debris.

Introduction

Figure A shows the arrangement of a wind turbine gearbox, which typically consists of three stages of gearing: a high-speed stage, an intermediate stage, and a planetary stage. The majority of wind turbine gearbox problems that cause outages are due to bearing spall and/or gear pitting^[1-3].

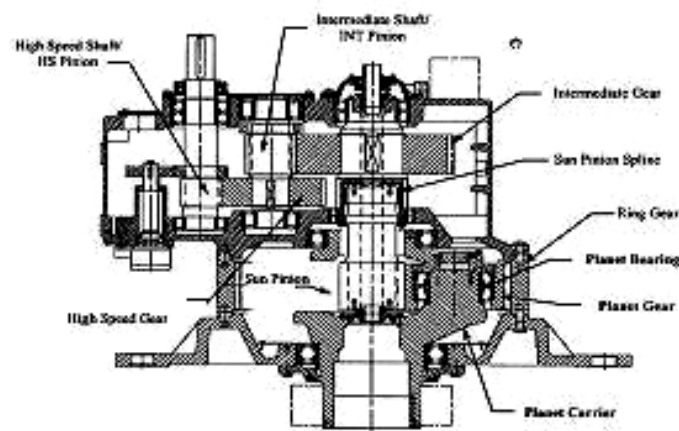

Figure A

Employing an oil debris sensor installed in the gearbox lube oil system provides the capability of detecting bearing and gear damage at an early stage and giving insight into the extent of the damage and its impact on the remaining life of the gearbox. Increasing particle counts have been successfully used as a notification to perform additional borescope inspection of the gearbox to better localize and assess the progression of damage.

Inductive oil debris sensors can be installed in either a full-flow or partial-flow configuration. In the full-flow configuration, 100% of the oil flow is passed through the sensor along with 100% of the debris particles. In a partial-flow configuration, the oil flow is divided and a portion of the flow is passed through the oil debris sensor while the rest is diverted, as shown in Figure B. In a partial-flow configuration, a number of factors can influence the amount of oil debris passing through the sensor. These factors include flow rate, sensor location, and sensor plumbing arrangement. It is recommended that some tests be performed to correlate the fraction of oil debris passing through the sensor as a function of oil flow rate for a given type of partial-flow sensor configuration.

Both full-flow and partial-flow configurations are suitable for wind turbine gearbox condition monitoring, as both provide comparable data trends.

Introduction
(continued)

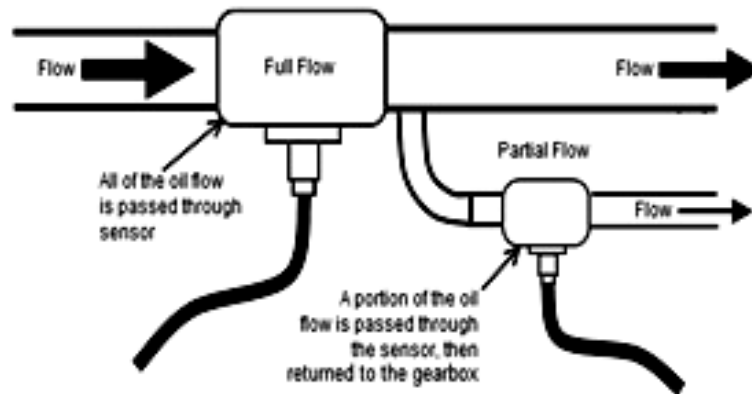

Figure B

Whether a full-flow or partial-flow configuration is used, the oil debris sensor is installed in the lube system at a point downstream of the gearbox oil return port and upstream of the filtration system. Typically only a single sensor is used, and it can be installed in either a return line or a supply line as long as it is upstream of the filtration system.

On-Line Condition Monitoring (Debris Monitoring) Procedures

1. Site Survey and Installation Planning

1.1. Review the lube oil system to determine the most suitable location to install the debris monitoring sensor. The sensor must be located at a point downstream of the gearbox oil return port and upstream of the filtration system and can be installed either before or after the pump. (See Figure C)

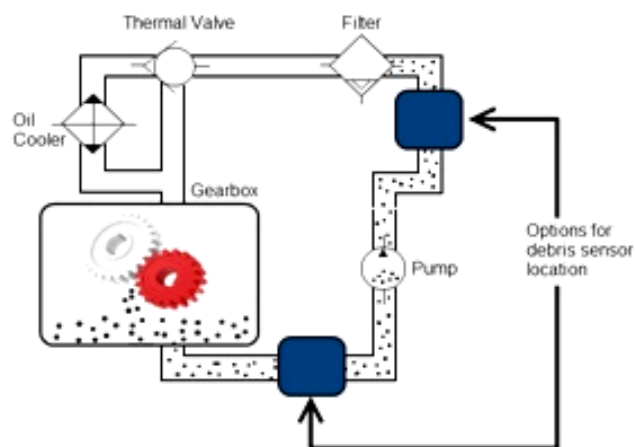

Figure C

1.2. If using a full-flow sensor, select a sensor bore that matches the lube oil line bore as closely as possible. This will ensure that the pressure drop across the sensor is minimized. If there is a difference between the oil debris sensor bore and the lube oil line bore, then a pressure drop analysis should be conducted prior to the sensor installation in order to confirm that the pressure drop across the sensor is acceptable.

If using a partial-flow sensor, select or install a bypass flow stream that supports the sensor manufacturer's recommended flow rate. Bypass filtration systems and oil sampling ports are typical install points. Consult with the sensor manufacturer for specific instructions. Ensure the bypass configuration maintains a suitable oil flow in the supply line to the gearbox lubrication points.

1.3. Ensure that there are no interferences and/or conflicts of space between the oil debris sensor and existing components.

1.4. Locate and mark the position where the sensor will be installed, as well as any bolts, brackets, and tubes that need to be replaced or repositioned.

1.5. Ensure that there is suitable power available for the oil debris sensor. Ensure that the power source has a switch or circuit breaker that can be turned off during sensor installation.

1.6. Ensure that all required tools and consumable materials are available and are on-site.

2. Sensor Electrical Installation

2.1. Connect the oil debris sensor to the SCADA or control/monitoring system (CMS) according to the instructions from the sensor manufacturer.

2.2. Ensure the switch or circuit breaker from the sensor power supply source is turned off.

2.3. Connect the oil debris sensor to the power supply according to the instructions from the sensor manufacturer.

2.4. Switch on the power to the sensor.

2.5. Perform a signal check by passing a metal particle through the sensor bore. Ensure that the sensor detects the particle and conveys this information to SCADA/CMS. When available, perform a sensor self-test to verify functionality and communications. Consult with the manufacturer for specific instructions.

3. Sensor Installation in Fluid Line

- 3.1.** Ensure the switch or circuit breaker from the sensor power supply source is turned off.
- 3.2.** Install the sensor in the lube oil line location that was marked during the site survey. Replace hoses, bolts, brackets, tubes, etc. as required.
- 3.3.** Perform a leak check for all installed lube system components, including sensor, hoses, and fittings/adapters.
- 3.4.** Perform a physical mounting integrity check to ensure that the sensor and all installed lube system components will remain secure without leaking, becoming damaged, or suffering degraded service life or performance.

4. Warning and Alarm Limit Configuration

Although all stages of gearing have experienced bearing problems, it is noteworthy that feedback from field experience suggests that high-speed shaft bearings and planet gear bearings are especially problematic. The former can be repaired in-situ whereas the latter requires gearbox replacement. This suggests that damaged high-speed shaft bearings should be replaced early in the damage cycle while damaged planet gear bearings should be run to the damage limit that maximizes production and minimizes secondary damage in the gearbox. Hence, gearbox damage inspection limits will be set on the basis of bearing damage. These same limits will also provide valid inspection points for gearing, since surface fatigue phenomena for bearings and gears progress in a similar manner.

The recommended parameters for indicating severity of bearing damage are:

- The total accumulated particle counts detected by the oil debris monitoring sensor
- An increasing rate of particle generation

A correlation can be defined between the accumulated particle counts detected by the sensor and the spall size on a damaged rolling element bearing. Thus, the maximum severity of damage can be defined as an alarm limit.

Summary

Condition monitoring is an effective technique for managing gearbox failures. Oil debris sensors, when installed within the gearbox lube system, provide reliable information regarding the health of the gearbox. Sensor data can be interpreted easily as a condition indicator that provides an early warning of bearing spall and gear pitting damage and quantifies the severity and rate of damage progression towards failure.

Oil debris sensors are a proven technology and have been in operation since the early 1990s. There are now thousands of these devices operating in a wide variety of machinery applications accruing millions of operational hours.

References

- [1] J. V. Rensselaer, "The Elephant in the Wind Turbine," *Tribology & Lubrication Technology*, pp. 38-48, June, 2010.
- [2] W. Musial, S. Butterfield, and B. McNiff, "Improving Wind Turbine Gearbox Reliability", NREL, Golden, Colorado, USA, NREL/CP-500-41548, 2007.
- [3] T. Jonsson, "Gearbox Repair Experiences," presented at Sandia 2006 Wind Turbine Reliability Workshop, Albuquerque, New Mexico, USA, 2006.

RP 819 Online Oil Condition Monitoring

The following recommended practice (RP) is subject to the disclaimer at the front of this manual. It is important that users read the disclaimer before considering adoption of any portion of this recommended practice.

This recommended practice was prepared by a committee of the AWEA Operations and Maintenance (O&M) Committee.

Committee Chairs:

Bruce Hamilton, Navigant Consulting

Jim Turnbull, SKF

Principal Author: Ryan Brewer, Poseidon Systems

Purpose and Scope

The scope of “Online Oil Condition Monitoring” discusses the utilization of online oil condition monitoring to assess the health of a wind turbine gearbox lubricant.

Gearbox lubricants are designed to provide a protective layer between contact surfaces, thereby significantly reducing friction and wear. They also transfer heat, contaminants, and debris out of the gearbox. Due to the extreme conditions wind turbines operate under (temperature swings, high torque, frequent start/stops, humidity swings), gearbox lubricants are specially formulated with additives such as oxidation inhibitors, corrosion inhibitors, extreme pressure protection, and anti-foam agents.

Maintaining a healthy lubricant is of critical importance to maximizing the operating life of a wind turbine gearbox. Over time, and as a lubricant is exposed to debris or contamination, temperature swings, and extreme loads, its ability to provide the expected level of protection degrades. Ineffective or improper lubrication can lead to highly accelerated wear rates, development of corrosion, reduced efficiency, and ultimately functional failure.

In addition to traditional offline sampling and analysis, many online oil condition monitoring technologies exist which can provide users early warning of lubricant degradation. This recommended practice provides a summary of available technologies and their use for effective lubricant health monitoring.

Introduction

Traditionally, the condition of lubricating oils has been determined through periodic oil sampling and laboratory testing. The methods for collecting gearbox oil samples and recommended analyses are discussed in detail in RP 102 and RP 104. A full laboratory oil analysis of an oil sample provides a detailed report of a lubricant's physical properties, quantitative analysis of key contaminants, and an indication of its remaining useful life. However, offline analysis methods provide limited early warning of lubricant degradation due to a combination of the limited number of oil samples from a given component, the significant time between sampling, typically 6 months or more, variability in lab analysis techniques, and contaminants which can rapidly fluctuate in concentration, such as wear debris and water.

Online oil condition sensors help to fill these information gaps and provide improved situational awareness when used with conventional offline methods. The real-time data provided by online sensing devices allows operators to identify and correct lubrication issues early, leading to improved long-term reliability and reduced lifecycle cost.

Online Oil Condition Monitoring

1. Sensing Technologies

A multitude of online oil condition sensors are available from several different manufacturers. The sensing technologies used can be grouped into the following categories:

- Impedance spectroscopy
- Conductivity sensing
- Infrared spectroscopy
- Moisture sensing
- Viscosity

The following sections describe the principles of operation of these devices and how they can be applied for wind turbine oil condition monitoring. Operators are encouraged to seek specific equipment recommendation and instructions from their selected device manufacturers.

1.1. Impedance Spectroscopy

Impedance spectroscopy methods utilize a set of electrodes immersed in the lubricant to measure the fluid's impedance over a range of frequencies. Impedance measurements consist of a magnitude and phase angle and are frequency dependent. Contaminants, additives, and oxidation by-products influence portions of the impedance spectrum. Properties such as anti-wear additive health, detergent/dispersant additive health, and dissolved/free water contamination can be detected and trended using impedance spectroscopy based devices.

Impedance based devices can provide the following fluid condition monitoring benefits:

1.1.1. Trend Analysis

Monitor impedance measurements to detect abnormal levels or patterns indicative of contamination or poor health.

1.1.2. Contamination and Remaining Useful Life Estimation

Some manufacturers provide data interpretation algorithms capable of providing remaining useful life estimates (estimate of time until oil properties reach unacceptable levels) and alarms for specific contaminations.

1.1.3. Additive Depletion Monitoring

Impedance-based devices are particularly sensitive to changes in additive levels in a lubricant. Some devices can even distinguish between surface protection additive loss and detergent/dispersant loss.

1.2. Conductivity

Conductivity-based devices operate on a similar measurement principle to impedance-based devices, using a set of electrodes immersed in the lubricant and measuring the electrical properties of the fluid between the electrodes. Conductivity measurements are performed at a fixed frequency and represent the inverse of the measured resistance at that frequency.

The measurement capabilities of a conductivity sensor are dependent upon the frequency at which conductivity is measured. They provide value in trending and alarming, but are limited in their capability by only measuring a single property of the fluid.

1.3. Infrared Spectroscopy

Infrared (IR) spectroscopy, or Fourier transform infrared spectroscopy (FTIR), has been used for many years to provide rapid, low cost, offline analyses of oil samples. The technology passes an infrared light source through a lubricant sample to an infrared detector. The light passing through the oil is influenced by oil contaminants and additives which absorb infrared radiation at specific frequencies. By comparing the frequency spectrum of new and used oil samples, it is possible to determine the lubricant properties, such as water, oxidation, glycol levels, and other breakdown products.

Through advances in electronics manufacturing techniques, IR technology is beginning to make its way into online sensing devices. Current technology does not have the refined measurement capabilities of laboratory devices; however, they do offer multi-parameter trending capabilities which can provide valuable, real-time insight into fluid condition.

1.4. Moisture Sensors

Water contamination has many detrimental effects on the performance of a lubricant, including accelerating oxidation, promoting corrosion, decreasing film strength, and increasing foaming. Water is also a difficult contaminant to control, particularly in gearbox applications which endure frequent temperature cycling, changes in atmospheric humidity, and do not experience high enough temperatures to evaporate water contamination. Online moisture sensors, often referred to as oil relative humidity (RH) or water activity sensors, can detect and trend water contamination in an oil lubrication system.

Nearly all online moisture sensors utilize a capacitive sensing element with a hydrophilic dielectric. As moisture is absorbed and desorbed by the lubricant and sensor, the measured capacitance value will change. These devices track moisture while it is present in its dissolved state and will not continue increasing as free water forms in a system.

Benefits of this technology to wind turbine gearbox lubricant monitoring include:

- Real-time tracking of dissolved water contamination during temperature and humidity swings that are missed by periodic offline analyses.
- Identifying turbines that have faulty desiccants.
- Identifying turbines that show potential for free water formation to allow prompt corrective actions.

1.5. Viscosity

Through monitoring the viscosity of the oil in a lubrication system, mechanical shear, as well as contamination, can be indicated. Reduced viscosity results in reduced film strength and increases the likelihood of excessive friction, wear, and heat generation. Elevated viscosity can result in reduced cold-start lubrication and oil filtration performance and decreased efficiency due to increased fluid friction.

There are several types of online viscosity sensing techniques including rotational, vibrational, and displacement based sensors. Each method has its own advantages and disadvantages which should be discussed with the respective monitoring equipment manufacturers. Due to the very high temperature sensitivity of viscosity measurements and the temperature swings experienced by wind turbine oils, devices capable of providing a temperature compensated output or trending measurements from a specific operating temperature are recommended.

2. Installation Considerations

Proper installation of an online oil sensing device is critical to ensuring reliable operation and expected sensor performance. The following sections detail the considerations required when selecting an installation location and plumbing the unit into the system. Always consult with the device manufacturer before installing a device.

2.1. Location Selection

The following considerations should be used to determine the optimal location for device:

- The device should be placed in a section of the lubrication system with sufficient flow to ensure a representative fluid sample is observed by the device.
- Ensure that the flow rate in the installation location does not exceed manufacturer recommendations.
- The device should not be placed at the bottom of a fluid reservoir or low point of a kidney loop as sludge and deposits may prevent accurate readings.

2.1. Location Selection

(continued)

- For many online condition monitors, post filtration installation locations are preferred to prevent electrode shorting or damage to moving parts. Wear debris monitors should be installed pre-filter.
- Ensure that the device's maximum ambient temperature will not be exceeded.
- Orient the device and/or design the device manifold in a manner that avoids entrapment of air bubbles or debris.

2.2. Plumbing

When installing the device into a system, consider the following:

- If using a manifold, ensure it is free of machining chips and any burrs have been removed.
- Lubricate any threads and/or O-rings prior to installation.
- Tighten all fittings per the recommended torque specification.
- After installation, engage the lubrication system and check for leaks.

Summary

Online condition monitoring enhances lubrication maintenance practices to help maintain healthy lubricant and ultimately extend gearbox life. Many online sensing devices are available which offer insight into a variety of oil condition parameters. The selection of an appropriate device depends on the monitoring objective, historical lubrication issues, site location, and the operator's budget. Regardless of the sensing method chosen, these technologies provide significant enhancement to a standalone offline sampling and analysis program by providing continuous data between the typical 6-month sampling intervals.

RP 821 Wind Turbine Blade Condition Monitoring

The following recommended practice (RP) is subject to the disclaimer at the front of this manual. It is important that users read the disclaimer before considering adoption of any portion of this recommended practice.

This recommended practice was prepared by a committee of the AWEA Operations and Maintenance (O&M) Committee.

Committee Chairs:

Bruce Hamilton, Navigant Consulting

Jim Turnbull, SKF

Primary Author: David Clark, Bachmann

Purpose and Scope

Blade condition monitoring systems may be capable of detecting and predicting failures and conditions that would otherwise be difficult or un-detectable in megawatt class wind turbines (this is not accurate, almost all are detectable with visual inspection). Several technologies have been tried or adapted from other markets with varying ability to detect emerging failure modes. While a mature system is currently not yet commercially available, the scope of “Wind Turbine Blade Condition Monitoring” provides insight into these technologies and discusses common failure modes of wind turbine blades.

Condition monitoring of blades may be required in the future as wind turbines and blades increase in size or complexity, new insurance or lender requirements emphasize predictable reliability, and offshore wind turbines increase in number.

Introduction

There are six major failure modes that can be monitored by a blade condition monitoring system. To date, no commercially available system available is capable of detecting all major failure modes, although several approaches have been tested in the recent decade.

Historically, there have been many attempts at adapting technologies from other industries to this application with limited operational or commercial success. In order to gain market acceptance, any blade condition monitoring system must be able to detect (unknown failures, trend damage progression, and confirm) known failure modes, be easily installed in existing towers, be sufficiently robust to withstand operational and environmental conditions, and provide reliable, cost-effective data on blade condition.

Wind Turbine Blade Condition Monitoring

1. Issues

There are three major concerns that must be addressed by a potential blade monitoring system:

- The technology or product must detect the likely encountered failure modes.
- The system must be capable of retrofitting existing towers.
- The system must be cost effective.

There is a new patent which does show promise in addressing all three of these issues.

2. Failure Modes

Figure 2. A typical blade plan and region classification.

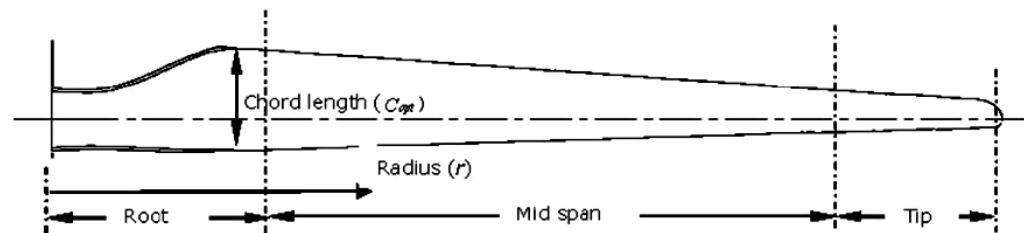

Figure A: A Typical Blade Plan and Region Classification.

2.1. Cracks

The ability to detect and provide early warning of cracks that typically occur at four common locations is a critical feature of blade condition monitoring. These crack locations include the root, leading edge, trailing edge, and tip, as shown in Figure A. While there is some uncertainty as to where a crack might occur in these locations due to variables from one blade manufacturer to the next, these four locations are generally consistent.

2.2. Delamination

Delamination predominately occurs at the trailing edge location and is caused by separation of the layers of composites and laminations. Separation may be caused by poor structural design, resin-rich areas with inadequate reinforcing matrix, poor quality control in manufacturing, accumulated stress-fatigue damage, and other factors.

2.3. Icing

An accumulation of ice on the blade surface is not conducive to safe or reliable wind turbine operation. Performance is degraded and the extra loading of ice on blades creates measurably uneven stresses. A blade monitoring system should be able to measure this accumulation of ice on the blades and provide the operator with a warning if loads exceed an established action threshold under operating conditions.

2.4. Imbalance (Either Aerodynamic or Static)

While blades are balanced from the factory within a tight tolerance, the operating environment and in-service wear or damage, e.g. leading edge erosion, may contribute to static imbalance in the field. In addition, aerodynamic imbalance may be result from variations in pitch index or sweep, improper placement of vortex generators or other aerodynamic aids, and variations in a blade's aeroelastic behavior.

There may also be uneven loading issues caused by wind shear, pitch deviation, tip in/out, and yaw deviation. All of these conditions can be monitored and will return improved performance, reliability, and production. If not monitored correctly, these operational conditions may appear as imbalance, but a best practices blade condition monitor and a trained analyst should be able to discern between these differences. In fact, this is an important function of a legitimate analyst.

2.5. Lightning Strikes

A blade condition monitoring system should be able to detect lightning strikes which contribute to one of the acknowledged failure modes. Like icing, lightning is very common in certain geographical locations. Therefore, best monitoring practices would dictate a system capable of detecting the occurrence of lightning strikes.

3. Technology Approaches

While no single product or technology today can measure or detect all of the possible failure modes common in a wind turbine blade, there are many current efforts that show promise for future applications. Below are the different technologies that may be applied:

3.1. Fiber Optic

Fiber optic sensors provide fast, high-resolution strain data from structures. They are light weight and would not affect performance. However, they are also difficult to install outside of initial blade manufacture, expensive, and do not detect all failure modes. This is likely why fiber optic technology has had limited success and adoption in the wind industry, although it is quite common in the aerospace industry. Installation usually involves cutting a shallow slot into the perimeter of the blade where the fiber optic strand is then laid and epoxied in place.

3.2. Strain Gauges

Strain gauges are inexpensive and easy to install/retrofit to existing turbines, but have proven to be troublesome in the field, having a lifetime as short as 6-9 months. Like fiber optic sensors, strain gages do not detect all blade failure modes, and their deployment has had limited success.

3.3. Acoustic

One wind turbine manufacturer has experimented with acoustic monitoring technology to detect blade cracks on a small number of towers. A focused microphone was placed on the top of the nacelle pointing forward towards the hub in an attempt to detect high-frequency acoustic signatures emitted by surface blade cracks. The detection capability of acoustic technology is limited to surface cracks and will not necessarily identify sub-surface delamination or uneven stress loading. While easy to install/retrofit, and relatively cost effective, acoustic technology has not been successful in the wind industry for the same reasons as fiber optic technology.

3.4. Vibration Sensors

This approach has been used with the sensors mounted near the hub, not on the blades. There is good measurement ability in some failure modes such as icing, imbalance, and less than optimal operational conditions. Again, there is limited detection capability for all common failure modes, but ease of installation or retrofit and cost-effectiveness are good. As a secondary benefit, vibration sensors for blade monitoring are usually applied at the main shaft bearing, which is also monitored. While main bearings are the least frequent failure in most drive trains, they are expensive to repair. Main bearing monitoring is an added benefit of this technology.

3.5. Laser Reference

This method utilizes a laser and prism system to compare the spatial differences and changes between known reference points within a wind turbine blade. This is done by aiming the laser at the prism and then re-directing the laser to internal locations. This technology would provide an excellent system for quality control of blades to measure manufacturing deviations in substrates and composites. Once again, the inability to detect all common failure modes, complexity of retrofit, and system cost all contribute to a lack of widespread acceptance.

4. A Perfect System Summary

As a note to system designers and integrators, the perfect wind turbine blade condition monitoring system would have the following features:

- The ability to detect all 6 common failure modes
- Robust sensors
- The ability to provide blade and blade position identification
- The ability to provide sensor identification
- A cost-effective method for either retrofit to existing turbines or installation at original manufacture
- Wireless and self-powered sensors to facilitate installation and data collection

5. Analysis and Software

Any good condition monitoring system is only as effective as the analyst who configures the alarms, monitors the data, and performs the analysis. So even with perfect blade CMS hardware, there is still a need for a certified and experienced vibration analyst with familiarity in wind turbine blade defect analysis to set-up and monitor the CMS for results.

Software should be able to configure appropriate measurements, alarming and displaying blade data in a familiar condition monitoring format consistent with industry standard vibration analysis practices and norms. This means industry standard measurements, units of measurements, labeling, measurement set-ups, alarming, charting and reporting.

With the blade CBM data streaming (off of the blades, tower, farm, and fleet), special considerations need to be made for appropriate data transportation, data storage, and resulting data analysis with the aforementioned software and appropriate analyst.

Reference

- [1] P. J. Schubel and R. J. Crossley, "Wind Turbine Blade Design," *Energies*, vol. 5, no. 9, pp. 3425-3449, Sept. 2012.

RP 831 Condition Monitoring of Electrical and Electronic Components of Wind Turbines

The following recommended practice (RP) is subject to the disclaimer at the front of this manual. It is important that users read the disclaimer before considering adoption of any portion of this recommended practice.

This recommended practice was prepared by a committee of the AWEA Operations and Maintenance (O&M) Committee.

Committee Chairs:

Bruce Hamilton, Navigant Consulting

Jim Turnbull, SKF

Principal Author: Wenxian Yang, Newcastle University, UK

Purpose and Scope

The scope of “Condition Monitoring of Electrical and Electronic Components of Wind Turbines” discusses the condition monitoring techniques used for detecting emergent failures occurring in the electrical and electronic components of wind turbines. It will cover the condition monitoring of wind turbine generator, power electronics, transformer, and cables.

Introduction

Wind industry practice shows that for onshore wind turbines, 75% of faults cause 5% of downtime and 25% of faults cause 95% of downtime. The majority of those 25% of faults are due to the failures of electrical and electronic components of wind turbines^[1]. Considering the wet and corrosive environment of offshore sites and the difficulties of accessing offshore equipment, it is believed that above figure will be more undesirable offshore. Therefore, the reliability and availability of wind turbine electrical and electronic components are critical to minimize life-cycle energy cost and benefit project financials^[2]. This highlights the importance of condition monitoring for electrical and electronic components of wind turbines, both onshore and offshore. In the following sections, condition monitoring techniques for detecting emergent failures in wind turbine generators, power electronics, turbine and substation transformers, and cables will be discussed.

Condition Monitoring of Electrical and Electronic Components of Wind Turbines

1. Condition Monitoring of Wind Turbine Generators

Since doubly-fed induction generators (DFIG) are the most common type in the wind turbine fleet, this section will focus on condition monitoring techniques for DFIG. The failure modes of permanent magnet generators, which are increasing in market share, are different from those of DFIG but still have many similarities.

The failure modes of DFIG include:

- Mechanical: bearing failure, rotor mechanical integrity failure, stator mechanical integrity failure, and cooling system failure
- Electrical: core insulation failure, rotor winding or insulation failure, stator winding or insulation failure, brush gear failure, slip ring failure, commutator failure, and electrical trip

The root causes of these failures are various, such as defective design or manufacture, poor installation, inadequate maintenance, heavy cyclic operation, severe ambient conditions, overload, over speed, low cycle fatigue, shock loading, high cycle fatigue, component failure, excessive temperature in windings, excessive temperature in bearings, steady or transient excessive dielectric stress, debris, dirt, corrosion, etc. Electrical current, flux, and power monitoring techniques have been well developed and are now successfully applied to the condition monitoring of wind turbine generators. Many characteristic frequencies have been identified from stator current signals for diagnosing those electrical failures occurring in the stator and rotor. The relevant information can be found from many openly published literatures.

1.1. Bearing

Since bearings account for over 40% of failures in generators, condition monitoring practice should concentrate on generator bearings. This can be achieved by onboard vibration monitoring and analysis, often in combination with temperature measurement. As the relevant techniques and monitoring procedures have already been introduced in AWEA O&M RP 811 and RP 815, they will not be repeated again in this section. Nonetheless, bearing faults may also be detectable from an analysis of generator electrical current and power signals. Bearings approaching failure contribute to changes in air-gap eccentricity, resulting in measurable effects on magnetic field.

1.2. Earth/Ground Fault Detection

While generator rotors, stators, and bearings are responsible for over 80% of failures of the generator, and usually stators exhibit more problems than rotors^[3], detection of other electrical faults in the generator cannot be ignored. For example, a single earth/ground leakage fault in a generator rotor winding is not serious in itself because the leakage current is relatively limited and cannot cause significant damage. But if multiple earth/ground leakage faults occur, higher current flows may eventually lead to the damage of winding, insulation, and even the rotor forging. To detect this type of fault early, a rotor earth/ground fault detector is required, which applies a DC bias voltage to the rotor winding and monitors the current flowing to the rotor body via an alarm relay. Should an alarm occur, it is essential to shut down the generator for further investigation and to prevent additional damage.

1.3. Electrical Discharge Monitoring

Electrical discharge monitoring is another important technique that is often adopted in the condition monitoring practice of wind turbine generators. The discharge behavior of a generator is complex but can be categorized in an ascending order of energy and potential damage as: corona discharge, partial discharge, spark discharge, and arc discharge. Electrical discharge is an early indicator of many electrical faults occurring in the generator that are usually related to integrity and the residual life of insulation. Today, many commercial on-line discharge monitoring systems have been developed and are used extensively in the condition monitoring of wind turbine generators.

1.4. Other Practices

Besides the aforementioned techniques, some other techniques are often adopted in practice for various condition monitoring purposes. For example, turn-to-turn faults in rotor or stator windings may lead to local overheating thereby increasing the temperature of the stator and rotor. Stator and rotor temperature is often measured as an indicator of overall condition.

In addition, the deteriorating performance of the brush gear in the generator can be detected by measuring brush or brush-holder temperature. A more advanced technique involves detecting the radio frequency energy generated by brush sparking, but this technique has not been commercially used in practice.

2. Condition Monitoring of the Power Electronics of Wind Turbines

Power electronics have been identified as the components that are most prone to fail, particularly in the wet, salty, and corrosive environment experienced off-shore. However, condition monitoring techniques for power electronics have not been fully developed. The reasons are various, but the major ones include:

- The failures of power electronics develop quickly, not allowing sufficient time to implement condition monitoring.
- Power electronic systems have a compact structural design that does not leave enough space to install condition monitoring transducers.
- The power electronic components are relatively cheap in price and easy to replace so there is no need to monitor their health condition online if the system can be easily accessed.

However, power electronics have a wide range of failure modes, which can be caused by excessive temperature, excessive current and voltage, corrosion, thermal fatigue, ionizing radiation, mechanical shock, stress or impact, etc. A recent survey based on 200 power electronics products from 80 companies shows that failures in the converter are 30% due to capacitors, 26% due to PCBs, 21% due to semiconductors, e.g. insulated gate bipolar transistor (IGBT), and 13% due to poorly soldered connections^[4]. Clearly, semiconductors and DC link capacitors are the most fragile components in wind turbine power electronics.

2.1. IGBTs

Temperature measurement is commonly used for monitoring the operation and health of wind turbine power electronic converters and inverters, but more advanced techniques are being researched today. The latest generation of IGBT products has been equipped with built-in thermocouples so that variations in IGBT temperature can be readily tracked. However, measured temperature is reliant on many factors, such as ambient temperature and load, thus, diagnosis of an IGBT high temperature condition still requires further investigation.

2.2. Capacitors

Two kinds of capacitors are being used in the wind industry as DC link capacitors in power electronic converters: the aluminum electrolytic capacitor and the metallized polypropylene film capacitor. The former is characterized by a high power density at a relatively low price, but is prone to fail in practical application. By contrast, the latter is more reliable and is able to withstand higher voltages and currents with a trade-off of comparatively lower power density. The condition of electrolytic capacitors can be approximated by trending three characteristic aging indicators: capacitance, equivalent series resistance, and the dissipation factor, and comparing the measured values of these parameters with recommended service thresholds. Although film capacitors are generally more reliable than electrolytic capacitors due to their self-healing capability, they are not free from failures. In contrast to the three aging indicators of an electrolytic capacitor, the film capacitor has only one ageing indicator: capacitance. Online condition monitoring of the capacitance of the film capacitor is exactly the same as that used for monitoring the electrolytic capacitor. Since temperature is the main ageing accelerator of capacitors, temperature measurement is also applied to condition monitoring for capacitors, although the result derived from temperature monitoring could be less reliable.

3. Condition Monitoring of Wind Turbine and Substation Transformers

Wind turbine and substation transformers are critical to the operation of wind farms. Their safety and reliability is critical to profitable power generation, transmission, and distribution. As the transformers are subject to very high mechanical, electrical, and thermal stresses during operation, failures and aging issues often occur in their windings, bushings, tap changers, insulation, and auxiliary equipment. Although consistent failure rates for these components have not been established in surveys conducted by different organizations, winding, bushing, and insulation systems have been identified as the three most fragile components in transformers. Moreover, these components are responsible for over 50% of plant downtime^[5].

3. Condition Monitoring of Wind Turbine and Substation Transformers (continued)

Modern transformer bushings are generally designed with closely stepped capacitive stress control layers. The basic insulating systems of capacitive stress controlled, high voltage bushings are classified as: resin-bonded paper bushing, resin-impregnated paper bushing, and oil-impregnated paper bushing. Despite the different types of bushings, bushing capacitance and dielectric dissipation factor are two key indicators of their operational condition. This is because both indicators are dependent on ageing, although they are also affected by the external environment, e.g. moisture, dirt, etc. Dielectric dissipation factor is a function of bushing capacitance. An increase in bushing capacitance for all bushing types indicates partial breakdowns between the control layers. A short-circuit between two control layers could have little influence on the general health condition of a bushing, but an increasing number of defective control layers can result in a complete breakdown of the insulation. Storm conditions (lightning, high winds, etc.) and/or routine switching actions may cause a transient overvoltage condition that could damage the insulating layer of the bushing. Tracking and reporting transient overvoltage conditions in transformers is recommended as an additional tool in the evaluation of transformer and bushing condition.

3.1. Other Practices

Besides monitoring bushing capacitance, dielectric dissipation factor, and transient overvoltage, the following techniques are often useful for condition monitoring of wind turbine and substation transformers:

3.1.1. Dissolved Gas Analysis

Over time, high electrical and thermal stresses in the transformer will cause breakdown of insulating materials and release gases due to localized overheating, corona, and arcing. Different concentrations of gases will appear depending on the intensities of energy dissipated by various faults, and the analysis of dissolved gases is very helpful for the identification of the root causes of the faults.

3.1.2. Partial Discharge Monitoring

PD is also an important means for detecting the deterioration of the insulation system of a transformer. Once a defect has developed on the insulator, partial discharge pulses will be generated at its point of origin. Hence, the initiation and development of an insulation defect can be identified if partial discharge pulses are detectable.

3.1.3. Temperature

Temperature measurement is used as an indicator of the operational and health/aging condition of transformer windings. Now, several approaches have been adopted for the measurement of transformer temperature. Among them, the most promising device is an optical fiber transmitter connected to a crystal sensor. The sensor converts an incoming light beam into an optical signal that can be correlated to sensor temperature. Currently, these devices have been tested but are not widely in service.

3.1.4. Vibration Analysis

Vibration sensors magnetically attached to the sides and top of the transformer tank may help detect changes in the mechanical integrity of transformer windings, e.g. winding looseness, and the tap changer. But the practice has shown that vibration analysis of transformers is quite complicated due to the many vibration sources, such as primary excitation, leakage flux, mechanical interaction, switching operations, etc.

3.1.5. Leakage Flux

This is a traditional method popularly used for detecting changes in winding geometry. It is known that any mechanical displacement of the windings can result in changes to the radial component of leakage flux. By using search coils that are installed in the transformer, these changes can be readily detected.

3.1.6. Analysis of Current Signals

This is a very popular approach used in the condition monitoring practice of transformers. This method can be used to detect the undesirable conditions in single phase or three phase transformers. Usually, all three phases of current signals are used together for either comparison or comprehensive analysis, e.g. Park's vector pattern analysis, to detect the early malfunction of transformers.

3.1.7. Monitoring of Bushing Oil Pressure

For oil-filled bushings, it is possible to measure bushing oil pressure, thereby checking for possible oil leaks. Since changes to bushing oil pressure can also be affected by the thermal overload or partial discharges, it is recommended that careful onsite investigation be conducted once a significant drop in bushing oil pressure is observed.

4. Condition Monitoring of Electric Cables

Power cables used on wind farms represent a large capital investment. They are usually reliable but are critical to the overall performance of the facility. Failures not only affect the power generation of individual wind turbines, but the production of the whole wind farm could be impacted. For this reason, monitoring and maintaining the condition of electric cables is of great significance to assure the profitable production of wind farms, particularly for those where cable installation and repair are difficult to carry out.

Different types of electric cables, e.g. paper/oil and extruded cables, are produced for different purposes. Cable systems used on wind farms are predominantly insulated with solid dielectric insulation, e.g. plastic and rubber based materials. Electric cable systems can fail for a number of reasons^[6]. The most common reason for failure on wind farms is poor installation technique. Low voltage cable systems (less than 1kV) commonly fail at the connectors due to overheating. One of the most effective tests for low voltage cable systems is the infrared assessment. See RP 601 and 602 Secondary Cables for more information.

Medium and high voltage cable systems can fail due to overheating at the connection points, but the predominant issue is insulation failure. Failure occurs when the local electric stress exceeds the insulation strength, e.g. a sharp metal protrusion in the insulation, a gas or air void is introduced where solid insulation should be, e.g. a lack of dielectric grease on a joint interface, or, as is most common, a more subtle mixture of these two cases. In either case, partial discharge arises and begins erosion process. The erosion process only advances during voltage stresses which are sufficiently high to turn on the PD ionization process. Voltage transients, which are very common at wind farms, intermittently turn on PD sites and cause sporadic erosion.

Manufacturer standards of modern solid dielectric components require the components to be PD free at stress levels well over the operating voltage, as they will not last long under continuous PD activity. Thus, IEEE, IEC, and ICEA standards require an off-line 50/60 Hz PD test with better than 5 pC sensitivity to determine whether or not components are in or out of specification. Since this standardized test can only be performed off-line it is typically performed during construction and then periodically during plant shutdowns. See RP 601 and RP 602 MV cable systems for more information.

4. Condition Monitoring of Electric Cables

(continued)

Wind farm cable systems are presented with some extreme and unusual requirements. For example, the cable systems are typically designed for 100% loading, i.e. they can cycle from 100% to virtually zero load, they operate at more than two times the stress of typical medium voltage cable systems, and they often have relatively long cable runs (longer than 1 mile). This combination of challenges is unusual for other types of power plants and utility distribution applications that use similar cable system components. These noted challenges are usually only seen in transmission class cable systems. For this reason, many owners have specified stringent commissioning test requirements, such as the off-line 50/60 Hz PD test. In some cases, owners have installed thermocouples to spot check cable systems. While it is possible to run an optical fiber in parallel with the cable system for distributed temperature sensing (DTS), it is not a common practice.

A more common practice is to minimize the number of underground joints and use above ground junction boxes. The junction boxes can be serviced using an infrared (IR) camera, and the most common overheating point, the cable accessory, can be checked for overheating during high load conditions to prevent damage to the cable insulation. IR cameras and off-line 50/60 Hz PD tests are complementary. There is virtually no IR signature associated with PD activity and there is not any PD activity at overheating connection points until the insulation is slightly damaged. In addition, junction boxes are convenient points for fault indicators, sectionalized during failure locating and predictive off-line insulation testing.

An important issue in partial discharge testing is the level of test voltage. Using an excessive test voltage will initiate partial discharge pulses that would not exist at normal operating voltages and may cause other damage that would not occur under normal operation. Therefore, it is recommended that system test voltage not be greater than 1.5 to 2 times the operation voltage.

Summary

Condition monitoring of electrical and power electronic components of wind turbines has long been overlooked in previous wind industry practice. It is now recognized as equally important to the condition monitoring of wind turbine drive trains, particularly with the increasing deployment of the wind turbines offshore or in remote locations.

Summary

(continued)

In contrast to condition monitoring of wind turbine drive trains, condition monitoring of wind turbine electrical and power electronic components requires dedicated techniques or methods. While some methods come from traditional ideas, e.g. temperature measurement, they have been applied using more advanced technologies in order to meet special needs of wind facilities. This motivates the invention and development of even more innovative techniques in this young industry.

In this recommended practice section, a number of commercially available condition monitoring techniques for generator, power electronics, transformer, and cables are briefly discussed in order to sketch an outline of the condition monitoring of the electrical and power electronics of wind turbines. However, the selection and practical application of these techniques is still reliant on the actual situations and physical requirements at each site. Moreover, care should be taken in the application of some techniques, such as partial discharge testing, to ensure they will not introduce negative effects or additional damage to the assets being monitored.

References

- [1] P.J. Tavner, *Offshore Wind Turbines: Reliability, Availability & Maintenance*, Stevenage, England: IET, 2012.
- [2] W. Yang, P.J. Tavner, C. Crabtree, Y. Fen, and Y. Qiu, "Wind Turbine Condition Monitoring: Technical and Commercial Challenges," *Wind Energy*, vol. 17, no. 5, pp. 673-693, 2014.
- [3] P.J. Tavner, L. Ran, J. Penman, and H. Sedding, *Condition Monitoring of Rotating Electrical Machines*, Stevenage, England: IET, 2008.
- [4] E. Wolfgang, "ECPE Tutorial: Reliability of Power Electronic Systems," ECPE, Nuremburg, Germany, April, 2007
- [5] A. J. M. Cardoso and L. M. R. Oliveira, "Condition Monitoring and Diagnosis of Power Transformers," *International Journal of COMADEM*, vol. 2, no. 3, pp. 5-11, 1999.
- [6] J. Densley, "Ageing Mechanism and Diagnostics for Power Cables -- An Overview," *IEEE Electrical Insulation Magazine*, vol. 17, no. 1, pp. 14-22, 2001.

RP 832 Lightning Protection System Condition Based Monitoring

The following recommended practice (RP) is subject to the disclaimer at the front of this manual. It is important that users read the disclaimer before considering adoption of any portion of this recommended practice.

This recommended practice was prepared by a committee of the AWEA Operations and Maintenance (O&M) Committee.

Committee Chairs:

Bruce Hamilton, Navigant Consulting

Jim Turnbull, SKF

Primary Author: Kim Bertelsen, Global Lightning Protection Services

Purpose and Scope

The scope of “Lightning Protection System Condition Based Monitoring” provides suggested methods for condition based monitoring (CBM) of the lightning protection system. Specific methods of monitoring are not provided but the requirements for monitoring are described.

Introduction

The main purpose of the lightning protection system is to provide sufficient protection for the wind turbine to avoid damages in the event of a lightning strike. The lightning protection system can prevent or reduce damage that results in forced production outages and long-term degradation of components.

Lightning Protection System Condition Based Monitoring

1. Monitoring Direct Attachment

1.1. Online Triggering CBM

As a minimum, it is recommended to monitor lightning strikes to the wind turbine by a simple trigger circuit that provides a digital signal in the event of a lightning strike. The trigger signal should be monitored by the controller of the wind turbine, and this triggering may be correlated with other CBM signals/data so eventually incidents can be compared to the occurrence of a lightning strike.

1.2. Parameter Measuring CBM

The online triggering CBM can be extended to also measure the typical relevant parameters of the lightning. By measuring such parameters, the chance of success in predicting and evaluating damage is further enhanced. These parameters are stored as values in the wind turbine data log and can be correlated with other events, trends, or developments that might originate from the specific time of triggering.

1.2.1. Peak Current

This parameter is the easiest to measure. It will tell if there is risk of damage for connection components or risk of magnetic field coupling, i.e. damage to other parallel electrical components.

1.2.2. Energy

This parameter provides information about overheating risk of conduction materials.

1.2.3. Charge

The charge will indicate the wear erosion on lightning attachment points and rotational transfer systems/bearings.

1.2.4. Current Rate-of-Change

The steepness of di/dt in a lightning strike will indicate whether there is a risk of coupled transients or failing insulation.

1.3. Wave Shape Logging CBM

As a supplement to the online triggering and parameter logging, the CBM can be extended to log the actual wave shapes of the lightning. The system logs and stores the curves. The curves can be used for further analysis of the lightning attachment.

1.4. Location Logging CBM

Each of the suggested systems can be expanded to either measure at several points or to do one detailed measurement. This will provide knowledge of where the lightning has attached and specific areas can be targeted for subsequent investigation or monitoring.

2. Monitoring Indirect Effects

2.1. Surge Protective Devices (SPD) Failure Monitoring

If the SPD system provides feedback, this feedback should be monitored. Furthermore, several systems use an upstream fuse that also needs to be monitored, if present. This monitoring may be done online, and any fault will require a service visit to the wind turbine to replace the defective component.

2.2. CBM of Surge Protective Devices

It is suggested that the operation of SPDs be monitored. By continuous monitoring and counting of transients, the SPD can be predictably maintained.

3. Inspecting the Lightning Protection System

On an annual basis, it is recommended that a full inspection is performed on all wear parts of the lightning protection system. The system should be inspected for excessive wear or defects. All adjustable systems should be inspected for correct adjustment and corrected if needed.

Reference

[1] *Wind Turbines - Part 24: Lightning Protection*, IEC 61400-24:2010, 2010.

Chapter 9 Quality Assurance



Operations and Maintenance
Recommended Practices

version 2017

RP 901 Quality During Wind Project Construction

The following recommended practice (RP) is subject to the disclaimer at the front of this manual. It is important that users read the disclaimer before considering adoption of any portion of this recommended practice.

This recommended practice was prepared by the AWEA Quality Committee. The committee would like to thank:

Primary Authors:

Concepcion Mendoza, Wanzek Construction, Inc.
Karen Tucker, Wanzek Construction, Inc.

Contributing Authors:

Thomas Brazina, EDP Renewables North America LLC
Ryan Griffin, Mortenson Construction
Gregory Lilly, E.ON Climate & Renewables North America
Scott Mathieu, EDP Renewables North America LLC
Gillian Saunders, Siemens
Fritz Oettinger, Vestas

The Committee first authored this recommended practice as a separate whitepaper that was published on May 18, 2017.

Purpose and Scope

The scope of “Quality During Wind Project Construction” addresses quality assurance and control during the construction phase of a wind site.

Introduction

The Quality Committee is focused on reducing the levelized cost of energy (LCOE) for wind and creating visibility for and attracting attention to world-class quality standards and processes that reduce wind project costs.

In particular, the construction phase of a wind farm is a key area for cost reduction initiatives. Reviewing the project financials, turbine supply represents approximately 65-75% of total costs, while construction represents an additional 25-35%.

With firm turbine prices, the construction phase of a wind farm poses the most financial risks due to unforeseen variable costs. These costs can significantly impact the internal rate of return (IRR) if not addressed.

Introduction

(continued)

“Quality During Wind Project Construction” includes four separate sample documents that together provide a template for quality assurance and control during the construction phase of a wind site. Certain details in the documents are specific to individual wind project sites but can be easily adapted to site-specific conditions.

- The “Quality Assurance/Quality Plan” provides a framework for attaining required quality levels during wind site construction. It provides management tools for executing quality assurance and quality control and includes documentation of quality protocols and responsibilities for a typical wind site construction project.
- The “Form of Job Books” provides a table of contents view of the typical inspections and tests that are performed and documented to assure quality of construction. Inspections may be deleted, added, or modified based on project specifics.
- The “Inspections and Test Plan” provides an example of a full inspection and test plan for “Civil Construction Block” in the “Form of Job Books”. A similarly detailed inspection and test plan exists for each section of the “Form of Job Books”.
- The “Quality Control Procedure” provides an example of the documented procedure accompanying the “Construction Period Road Inspection” subsection of the “Civil Construction Block”. A similarly detailed procedure exists for each inspection in the full inspection and test plan.

Quality Assurance/Quality Plan

The “Quality Assurance/Quality Plan” provides a framework for attaining required quality levels during wind site construction. It provides management tools for executing quality assurance and quality control and includes documentation of quality protocols and responsibilities for a typical wind site construction project.

1. Revision History

Table A: Revision History

| Revision | Date | Description | Approved |
|-----------------|-------------|--------------------|-----------------|
| 0 | | | |
| 1 | | | |
| 2 | | | |
| 3 | | | |
| 4 | | | |

2. Introduction/Purpose

The intended purpose of this quality control plan (QCP) is to establish a formal quality assurance (QA) program for the subject project to ensure compliance of the construction effort with the project specifications, applicable codes and standards, and drawing requirements.

The goal of this QCP is to provide a framework for attaining the required level of quality in construction by delineating individual quality assurance/quality control (QA/QC) responsibilities, providing appropriate management tools for their diligent use, establishing procedures for the execution of QA/QC responsibilities, establishing documentation protocols, and ultimately instilling in each individual worker a commitment to produce quality work at all times.

3. Scope

This QCP is applicable for the indicated project and the scope of work contractually assigned to Company Construction Inc., its subcontractors, and its suppliers.

4. Management Responsibility

4.1. Quality Policy

It is the responsibility of Company Construction, Inc. to provide and maintain an effective QCP throughout the duration of the contract. To accomplish our goals of completing the timely construction of the work or project in compliance with the contract documents and applicable codes and standards while providing a safe work environment for our employees and subcontractors, Company Construction, Inc. shall ensure the performance of sufficient pre-planning, inspection, and testing of all work performed incident to this construction effort. The pre-planning, tests, and inspections include all subcontracted and self-performed work. All test and inspections will be performed to validate the quality of materials, workmanship, and functional performance requirements mandated by the contract documents. Test results and inspections will be documented on the appropriate forms and accompanied by a photo and/or video documentation as determined by Company Construction, Inc.

4.2. Organization

4.2.1. President and Vice Presidents

The president and vice presidents are responsible for establishing the direction for quality control throughout Company Construction, Inc.

4.2.2. Director of Project Management

The director of project management (DPM) is responsible for ensuring that the organization adopts and adheres to the quality policy. The director of project management is also responsible for gathering feedback from clients and ensuring that Company Construction, Inc. is an organization committed to customer satisfaction and continuous improvement.

4.2.3. Quality Control Management Team

The quality control management team (QCMT) is responsible to develop policies and procedures that improve quality. The quality control management team is also responsible to measure the quality of the services and products that are provided to our clients and address continual improvement of the quality control program. The quality control management team shall be responsible for the content of the quality control plan. The quality control management team shall review and approve inspection and test plans. The quality control management team shall review and approve non-conformance/corrective action reports. The quality control management team shall assist the project team with all quality related questions.

4.2.4. Project Managers

Project managers (PM) work with the director of project management and the quality control management team to address quality issues and assist with gathering information. Project managers are responsible for implementation of quality in the field and customer satisfaction. The project manager shall review and approve non-conformance/corrective action reports.

4.2.5. Lead Field Engineer

The lead field engineers (LFE) are responsible for overseeing quality in the field and customer satisfaction. The LFE shall develop and implement project specific plans and procedures related to quality. The LFE shall be responsible for reviewing all inspections and test reports. The LFE shall report to the QCM and the PMs all quality related metrics, reports, and issues. The LFE shall assist the PMs with arranging and monitoring third party testing.

4.2.6. Field Engineers

The field engineers (FE) shall be the quality control representatives. The FEs shall follow the guidelines and requirements of the QCP. The FEs shall initiate, follow through, and report on quality related items to ensure that the requirements of the client and Company Construction, Inc. are met. The FEs shall ensure that all required inspection and testing is completed properly. The QCMT, LFE, and the PMs will jointly determine the necessary number of FEs and/or quality organization based on project size, complexity, and scope. FEs shall create and update inspection and test logs. FEs shall follow the guidelines herein, perform inspections and tests, complete the proper documentation and applicable check lists, and report non-conforming conditions to the LFE, project superintendent, and, if appropriate, the PM. FEs shall coordinate, review, and approve third party testing. FEs may be required to perform inspections and tests.

4.2.7. General Superintendent

The general superintendent shall be aware of and follow the guidelines and requirements of the QCP. The general superintendent shall coordinate corrective action when required.

4.2.8. Area Superintendent

The area superintendents shall be aware of and follow the guidelines and requirements of the QCP. Area superintendents shall coordinate with the FEs in auditing the crew foreman's work to ensure the QCP is being followed.

4.2.9. Crew Foreman

Crew foremen shall be aware of and follow the guidelines and requirements of the QCP and the applicable procedures. Crew foremen shall work with the FEs to assure all client and Company Construction, Inc. quality requirements are met and procedures are followed. Crew foremen may be required to perform inspections and tests and complete the inspection documentation forms. Crew foremen shall coordinate with the FEs in auditing the leadmen's work to ensure the QCP is being followed.

4.2.10. Leadmen

Leadmen shall be aware of and follow the guidelines and requirements of the QCP and the applicable procedures. Leadmen shall work with the FEs to assure all client and Company Construction, Inc. quality requirements are met and procedures are followed. Leadmen may be required to perform inspections and tests and complete the inspection documentation forms.

4.2.10. Leadmen

(continued)

Leadmen are supervision's first line of quality representation in the field. Leadmen are required to inspect all installation work prior to FEs performing their quality inspections.

4.3. Resources

Company Construction, Inc. shall employ sufficient personnel to implement this QCP. Personnel shall be knowledgeable and properly trained in the work discipline to which they have been assigned. Company Construction, Inc. shall provide qualified agencies, laboratories, consultants, or contractors as necessary to implement the QCP.

5. Drawings and Other Document Control

5.1. Purpose

The purpose of "Drawings and Other Document Control" is to ensure that: pertinent documents are available at points of use, obsolete documents are promptly removed from use, and obsolete documents are retained, suitably marked, and filed.

5.2. Scope

The scope of this section covers: documents from customer/owner, engineer, and Company Construction, Inc. subcontractors and suppliers, as-built documents, third party codes, and standards and submittals.

5.3. Method (Procedure)

The LFE is responsible for this procedure but can delegate portions or all responsibility to competent personnel. Company Construction, Inc. subcontractors and suppliers are responsible for applicable section(s) of this procedure and must provide suitable document control.

5.3.1. Transmittals

The documents received are checked against the letter of transmittal to assure that there are no missing or illegible documents. As is appropriate, the customer/owner, supplier, subcontractor, or consultant is notified in writing of any deficiencies or discrepancies.

5.3.1. Transmittals

(continued)

The documents are logged into the project file log by their respective numbers. If required, one copy will be distributed to customer/owner, supplier, subcontractor, or consultant as is appropriate. Documents are accompanied by a written transmittal or submittal letter. Customer/owner, supplier, subcontractor, or consultant that receives copies is required to acknowledge in writing within 3 working days receipt of the associated documents.

5.3.2. Revisions and Current Documents

If the document(s) received is a revision, obsolete copies are identified as “Void” or “Superseded”. All void or superseded documents shall be filed in their respective void or superseded file.

A log is kept of current documents. The log shall indicate acknowledgement from customer/owner, supplier, subcontractor, or consultant that information was received. Past due acknowledgements shall be followed up on. This log will be administered by the LFE on site and any new revisions shall be facilitated through the LFE.

5.3.3. As-Built Documents/Red-Lining

Company Construction, Inc.’s master set shall also be used as the as-built documents. For self performed work by Company Construction, Inc., subcontractors, and suppliers, each shall be responsible for red-lining as appropriate. The official as-built documents will remain with Company Construction, Inc. until turned over to customer/owner at the end of construction. Red-lining shall be done as changes occur. If revisions to documents are received without the previous changes incorporated, the later revision must be red-lined with the previous changes. The LFE shall facilitate and monitor this process throughout the project duration. The LFE shall perform or delegate weekly inspections of the as-built documents to ensure correctness and adherence to prior agreements.

Final as-built documents incorporating all Company Construction, Inc., subcontractor, and supplier data shall be submitted to the owner/customer in accordance with contract requirements. An electronic copy shall be retained by Company Construction, Inc. for future reference.

5.3.4. Submittals

Company Construction, Inc. shall implement a process to review contract documents, specifications, applicable codes, and Company Construction, Inc. specifications to determine submittal requirements. Company Construction, Inc. shall create a submittal log listing all submittals required by the various entities, contract, or necessity to complete the work. The submittal log shall identify the specific party that is responsible for generating the submittal and will also identify if the submittal requires approval and the associated due dates. Company Construction, Inc. shall be responsible for performing a review of all submittals prior to distribution.

Company Construction, Inc. shall review the submittal log weekly. The report will be used to identify any past due items as well as near term items.

5.3.5. Review of Shop Drawings/Submittals

Shop drawings/submittals shall conform to contract specifications. Submittal shall clearly indicate how the subcontractor or supplier intends to comply with specifications. Submittal shall provide evidence of conformance to specified materials, manufacturer, model numbers, and performance standards. Submittal shall provide a specific procedure for presentation, consideration, review, approval, use, and documentation of substitutions. Submittal shall confirm that the work complies with stipulated standards.

Company Construction, Inc. shop drawings/submittal procedure shall provide for coordination between other subcontractors and suppliers. Particular attention shall be paid to conflicts with work provided by others, interface points, and mechanical and electrical requirements and interface.

Company Construction, Inc. shop drawings/submittal procedure shall confirm that finishes conform to specifications. Upon receipt of a returned shop drawing/submittal, a record is created in the submittal log.

5.3.5. Review of Shop Drawings/Submittals

(continued)

Company Construction, Inc. shall review all comments made by the engineer/ owner/customer and confirm all questions are answered. Company Construction, Inc. shall determine if any comments result in a change to the contract. Using a transmittal/ submittal, forward the documents to the appropriate party. Clearly note any further action that is required, provide a “respond by” date, and keep a file copy. Submittals that are rejected must be revised and re-submitted. Forward record copies to the appropriate party.

6. Process Control

6.1. Requests for Information (RFI) Process

6.1.1. Purpose

The intent of the requests for information process is to provide a formal and documented communication process for the purpose of:

- Securing clarification when requirements are not clear or are conflicting
- Obtaining required information for construction activities that are not available in the contract documents
- Communicating non-conformance reports for disposition and/or approval to “use as is” or “repair”

6.1.2. Scope

The scope of the requests for information process covers all issues relative to fulfillment of contract requirements. RFI processes shall be employed between Company Construction, Inc. and its consultants, subcontractors, and suppliers, as well as the customer/owner.

6.1.3. Method (Procedure)

The lead field engineer or designee is responsible for the execution of this procedure. Company Construction, Inc. consultants, subcontractors, and suppliers shall have an equivalent procedure of their own.

6.2. Issue Management

6.2.1. Purpose

The purpose of issue management is to organize project information by issue. This allows for quick reference of any particular subject and supports bringing all issues to closure in a timely manner.

6.2.2. Scope

The scope of issue management is any issues that arise at any stage of a project from inception to close-out and warranty. Issues can be related to cost, schedule, scope of work, specifications, estimates, quotations, documents, contractor, subcontractor, owner/customer, RFIs, and responsibilities. Company Construction, Inc.'s project issue log shall be used to record, inventory, track, and close issues.

6.2.3. Method (Procedure)

At such time as an issue arises, or it is determined by the project team that an issue may arise, the following information shall be tracked: date of issue, description of issue, issue progress, issue resolution date, and description of issue resolution. All documents, regardless of origin, that are applicable to an issue shall be linked to that issue in the issue folder.

The PM shall affix responsibility, initiate any cost or charge calculations, issue notifications to the parties involved with a specific issue, direct work, obtain authorizations, and effect settlement. All tasks shall be identified and documented in the respective issue number assigned.

6.3. Plan of the Day Meeting/Report

6.3.1. Purpose

The purpose of the plan of the day meeting/report is to establish an effective communication process for indicated project construction activities.

6.3.2. Scope

The following is a summary list of the items that will be discussed at the plan of the day meeting and included in the plan of the day report (POD):

- Project milestones
- Construction activities
- Site safety
- Project issues
- General construction status

6.3.3. Method (Procedure)

The LFE or designee is responsible for the execution of this procedure. The LFE or designee shall coordinate with project team members at a specific time daily to conduct the plan of the day meeting. Upon completion of the plan of the day meeting, information discussed shall be recorded on the POD report and issued to all applicable parties.

7. Civil

7.1. Purpose

The purpose of this section is to establish and delineate the task planning and quality assurance methods and procedures to be used for the testing, examination, and inspection of site roadway, crane pad, and foundation excavation and backfill.

7.2. Scope

The following is a summary list of the operations and items for which quality control functions will apply:

- Road subgrade width and compaction
- Road final grade, width, profile, and compaction
- Foundation construction
- Crane pad construction
- Site reclamation

7.3. Method (Procedure)

The LFE or designee is responsible for the execution of this section. Prior to execution of work, a planning meeting shall be held. At the planning meeting, the project superintendent, civil superintendent and project manager shall review project specifications and installation procedures required per engineering/customer/owner requirements.

A survey control system for those items deemed necessary by Company Construction, Inc. shall be established and baselines/benchmarks shall be located on-site. As deemed appropriate by Company Construction, Inc., survey work performed by or for subcontractors may be independently verified by an independent professional surveyor provided by Company Construction, Inc..

The customer/owner shall be responsible to provide the precise location of each WTG. Company Construction, Inc. shall obtain customer/owner approval of the physical location of each WTG prior to beginning work at each location.

7.3.1. Subcontractors

Company Construction, Inc. subcontractors shall have a procedure of their own that equals or exceeds this procedure. Prior to execution of work, a planning meeting shall be held. At the planning meeting, the subcontractors shall demonstrate the quality plan that will be followed. Subcontractors shall also provide examples of supporting documentation to verify compliance with the quality plan for the work.

7.3.2. Site Access Roads

Prior to performing any road construction or placing any new road material, the road position shall be verified by a survey which shall indicate through the use of marking stakes the precise location of the roadway easement and the position of the road within the easement. The surveyor shall provide documentation in a format approved by Company Construction, Inc. that the roadway easement stakes and road location are in the proper position.

Prior to performing any road construction or placing new road material, the road subgrade will be inspected by an independent testing agency. The documentation provided by the independent agency shall include, as a minimum, the information detailed in Section 7.3.7.

7.3.2. Site Access Roads

(continued)

Upon completion of roadway construction, the roads and any newly installed drainage structures will be inspected for proper placement, width, thickness, grade elevation, crown, and side slope and tested for compaction. Placement, width, thickness, grade elevation, crown, and side slope shall be documented on the “C-1 Road Inspection” form and “C-2 Drainage Structure Inspection” form. The compaction testing will be performed and documented by an independent testing agency. The documentation shall comply with the provisions outlined in Section 7.3.7.

The civil inspection forms and compaction test reports shall become part of the turnover package to the owner/customer.

7.3.3. Foundation Excavation

Prior to foundation excavation, the PE or designee shall verify that the turbine location coordinates are accurate. Foundation excavation shall be inspected and documented by an independent testing agency. The inspection shall be reviewed and approved by the testing agency’s geotechnical engineer. The documentation shall comply with the provisions outlined in Section 7.3.7.

Turbine foundation excavations shall be visually inspected prior to concrete placement to ensure the bottom excavation is consistent with design requirements. A photographic record of the excavated area shall be made immediately prior to concrete placement. The “F-1 Foundation Excavation Inspection” form shall be completed prior to concrete placement.

The “C-5 Drain Tile Repair Inspection” form shall be completed if any drain tile is damaged during construction operations.

The “F-1 Foundation Excavation Inspection” form and third party subgrade acceptance report shall become part of the turnover package to the owner/customer.

7.3.4. Foundation Grounding and Pre-Backfill

A visual and mechanical inspection of grounding system shall be conducted to ensure grounding cable, ground rods, and exothermic or mechanical ground connection(s) are in compliance with project drawings and specification. The “F-9 Foundation Grounding and Pre-Backfill Inspection” form shall be utilized on each inspection. A photographic record of the ground grid shall be made prior to commencing foundation backfill operations. The foundation ground grid shall be tested according to contract specification upon backfill completion. The “F-9 Foundation Ground Grid Inspection” form and ground grid test results will become part of the turnover package to the owner/customer.

Prior to placing earth backfill at turbine foundations, an inspection shall be conducted to ensure all cracks have been sealed on foundation and all debris has been removed from foundation area. Once concrete strength has reached design specifications, backfill will proceed.

7.3.5. Foundation Backfill

A meeting will be held with the third party testing agency to discuss the backfill testing parameters. Foundation backfill shall be completed and tested according to engineer specifications and/or owner/customer specifications. The compaction testing will be performed and documented by an independent testing agency. The documentation shall comply with the provisions outlined in Section 7.3.7. The compaction test report shall become part of the turnover package to the owner/customer.

7.3.6. Crane Pad

Upon completion of crane pad construction, the pad will be inspected for length, width, distance from center-of-foundation to center-of-pad, levelness, and compaction found. Length, width, center-to-center distance and levelness will be documented on the “C-3 Crane Pad Inspection” form. The compaction test will be performed and documented by an independent testing agency. The documentation shall comply with the provisions outlined in Section 7.3.7. The compaction test report shall become part of the turnover package to the owner/customer.

7.3.7. Material Compaction Report Items

Independent testing agency inspection and test reports for material compaction shall include, but shall not be limited to, the following:

- Date
- Location of test
- Description of material tested
- Test reports shall reference project specifications.
- Description of tests performed including references to appropriate standards
- Material moisture content
- Material wet density
- Material dry density
- Sieve analysis, when deemed necessary by engineer of record
- Material compaction value in place
- Name and signature of test technician
- Name, signature, and registration number of professional engineer responsible for the content of the report
- Stamp or seal of professional engineer responsible for the content of the report as required per specifications
- A statement that the test results pass or are not in compliance with the applicable requirements.

8. Wind Turbine Generator Foundation

8.1. Purpose

The purpose of this section is to establish and delineate the task planning and quality assurance methods and procedures to be used for the testing, examination, and inspection of reinforcing steel installation, formwork, concrete placement, and WTG base grout placement.

8.2. Scope

The following is a summary of the operations and items for which quality control functions will apply:

- Concrete mix design approvals
- Ready mix supplier qualifications
- Reinforcing steel installation
- Formwork
- Embedded items
- Concrete placement
- Concrete testing
- Concrete curing and protection
- Grout placement

8.3. Method (Procedure)

The PM or designee is responsible for the execution of this procedure. Company Construction, Inc. subcontractors shall have an equivalent procedure of their own.

8.3.1. Concrete Mix Design Approval

The PM or designee is responsible for execution of this procedure. Using the submittal procedure, Company Construction, Inc. shall request and obtain from the ready mix concrete supplier the concrete design information, stamped and certified by a registered professional engineer, providing a detailed description of the concrete mix or mixes the supplier intends to use. This information shall also include compressive strength test results of the actual mix or mixes the supplier intends to use.

Upon receipt of the mix design information and compressive strength test results, Company Construction, Inc. shall, using the submittal procedure, forward the information and results to the structural engineer of record responsible for the foundation design. The structural engineer of record shall review the information and results and provide Company Construction, Inc. specific direction, if necessary, as to the suitability for use, or concrete mix design modifications necessary to make suitable for use. Company Construction, Inc. shall transmit the review and direction of the design professional to the ready mix supplier. Upon conclusion of this process, at such time as the structural engineer of record has approved the mix or mixes to be used, the structural engineer of record shall provide their approval in writing to Company Construction, Inc.. Once approved by the structural engineer, Company Construction, Inc. shall submit approved design to owner/customer.

8.3.1. Concrete Mix Design Approval

(continued)

Upon successful completion of the steps outlined in this section, the PM or designee shall hold a pre-placement planning meeting that shall include the concrete supplier batch plant manager, batch equipment operator, delivery truck dispatcher, and Company Construction, Inc. FE, superintendent, and/or foremen, as deemed appropriate by the PM. The purpose of this meeting is to plan in detail the work to be completed, the expectations to be met, paying particular attention to the quality and consistency of the concrete, the delivery time requirements, truck cycle times, number of trucks to be used, truck rejection parameters, truck wash out requirements, length of work day, location of work, communication protocol between Company Construction, Inc. and concrete supplier, safety requirements, and training. Subsequent pre-pour meetings shall be held as deemed appropriate by the PM or designee.

No structural concrete may be poured on the subject project until this process is complete.

8.3.2. Mill Certification

A mill certification form shall be provided by the manufacturer at the time of delivery of the anchor bolts, embed rings, and reinforcing steel used on the project. Embedment of these items shall not take place until the mill certifications have been received by Company Construction, Inc.. All mill certifications shall be submitted to the structural engineer for approval. The mill certifications shall become part of the turnover package to the owner/customer.

8.3.3. Pre-Concrete Placement

Pre-concrete placement forms are required to be completed prior to each mud mat, base, and pedestal foundation installation. The responsible foremen for each discipline of work, i.e. formwork, reinforcing steel installation, anchor bolts, electrical, and other embeds, will personally indicate satisfactory completion of their work by initialing the appropriate form prior to all concrete placements. These forms will become part of the turnover package to the owner/customer.

The following forms shall be completed prior to concrete placement:

- F-1 Foundation Excavation Inspection
- F-3 Anchor Bolt Cage Inspection
- F-4 Foundation Conduit Inspection
- F-5 Base Pre-Pour Inspection
- F-7 Pedestal Pre-Pour Inspection

8.3.3.1. Structural Engineer Approval

The structural engineer of record shall review the formwork, reinforcing steel installation, anchor bolt cage installation, electrical, and other embeds prior to concrete placement. This review shall be conducted at the start of the WTG foundation operations. At a minimum, two (2) foundation bases and two (2) foundation pedestals shall be inspected and approved by the structural engineer of record prior to concrete placement.

8.3.4. Concrete Placement

A concrete placement form will be completed for every mud mat, base, pedestal, or other concrete placement executed on this project by Company Construction, Inc.. These forms will become part of the turnover package to the owner/customer.

The following forms shall be completed during concrete placement:

- F-2 Mud Mat Inspection
- F-6 Base Concrete Placement Inspection
- F-8 Pedestal Concrete Placement Inspection

8.3.5. Concrete Testing

An independent testing company will be utilized to sample and test concrete from each placement. A record of concrete test specimen results will be provided by the independent testing company using their standard report form. Concrete test cylinders shall be made following the recommendations of the ACI, with one set made within the first 50 cubic yards placed and one additional set made within each 150 cubic yards placed thereafter or according to foundation specifications. Cylinders shall be made, handled, and cured in accordance with ASTM C31 and shall be strength tested in accordance with ASTM C39 along with foundation specifications. Testing reports shall become part of the turnover package to the owner/customer.

9. Wind Turbine Generator Component Receiving

9.1. Purpose

The purpose of this section is to ensure that receiving, inspection, and testing requirements, as required by applicable code, standard, or regulatory body and as described in the project contract documents, are fulfilled by Company Construction, Inc., a subcontractor, or a supplier, as may be applicable.

9.2. Scope

All work including direct and indirect purchased material and equipment within the scope of work described by the project contract is covered by this procedure. Inspection and testing may be performed by Company Construction, Inc., a subcontractor, or a supplier, as may be applicable.

9.3. Method

The LFE or designee is responsible for the execution of this procedure. Company Construction, Inc. subcontractors and suppliers are responsible for using this procedure or an equivalent one of their own for work covered by the contract for their services.

All incoming material and equipment shall be subject to a receiving inspection upon arrival utilizing the following inspection forms:

- R-1 Controller Receiving Inspection
- R-2 Tower Section Receiving Inspection
- R-3 Nacelle Receiving Inspection
- R-4 Hub Receiving Inspection
- R-5 Blade Receiving Inspection

The receiving inspections shall be performed to assess the condition of the item(s) being received including verification of quantities, model numbers, serial or mark numbers, and compliance with the contract or other document which authorized its purchase, visual inspection, or non-destructive testing for damage or deterioration and compliance with applicable design tolerances.

A photographic and/or video record of all incoming components, equipment, and materials which are actually damaged or deteriorated or suspected of damage or deterioration shall be made.

All deliveries shall be logged and recorded into the plan of the day (POD) report or a suitable delivery log.

All testing shall be performed in accordance with applicable codes, standards, or regulatory bodies. Test reports shall be generated by the party performing the test and provided to Company Construction, Inc. within five (5) calendar days of completion.

9.3. Method

(continued)

Projects shall maintain product identification and material traceability according to the requirements of the contract. Tracking logs and receiving forms shall be set up in aiding this process. All material manufacturer and receiving records shall be filed on site and recorded in the tracking logs. Where appropriate, the owner/customer shall participate in the inventory and inspection of received goods. The inventory shall validate count, conformance with specifications, damage, if any, and place of storage or use upon offloading. Any deficiencies shall be noted on the appropriate receiving inspection form and communicated to the transportation company and vendor. In addition, a non-conformance report shall be issued to the vendor and applicable parties.

10. Wind Turbine Generator Installation

10.1. Purpose

The purpose of this section is to establish and delineate the quality assurance methods and procedures to be used for the erection, assembly, testing, examination, and inspection of wind turbine generator components.

10.2. Scope

The following is a summary list of the operations and items for which quality control functions will apply:

- Tower section erection
- Grout installation and testing
- Base tensioning and testing
- Rotor and nacelle construction
- Tower wiring
- Mechanical completion

10.3. Method

The LFE or designee is responsible for the execution of this procedure. Company Construction, Inc. subcontractors are responsible for using this procedure or an equivalent one of their own. As applicable, Company Construction, Inc. shall incorporate the manufacturer installation procedures into the QCP by utilizing the manufacturing check lists or by modifying Company Construction, Inc. internal inspection forms.

10.3.1. Base Erection

The “E-1 Base Erection Inspection” form shall be utilized or modified as appropriate for the specific manufacturer prior to the erection of base section. The “E-1 Base Erection Inspection” form shall become part of the turnover package to the owner/customer.

10.3.2. Grout Installation and Testing

After the base tower section is erected, the base tower will be grouted with an engineer approved high strength grout which meets the design specifications of the structural engineer of record. Grout shall be placed according to grout manufacturer installation procedure and recommendations. The “E-2 Grout Placement Inspection” form shall be completed for every tower base.

Company Construction, Inc. or an independent testing company shall take grout cube samples for testing. The independent testing company shall perform strength testing of grout cubes.

Grout test cubes shall be made, handled, and cured following the requirements of ASTM C1107. Only brass molds with clamped covers shall be used. Release agents shall not be used in the molds. Reference the foundation IFCs for total amount of grout cubes to be made for each WTG grout base. Grout shall be tested for compressive strength following the requirements of ASTM C109.

The grout placement inspection form and grout compressive strength test results shall become part of the turnover package to the owner/customer.

10.3.3. Base Tensioning

Once the base tower grout has reached the specified minimum design strength, the foundation anchor bolts may be tensioned. After the foundation anchor bolts are initially tensioned, the tension will be verified by a Company Construction, Inc. PE or designee. The tensioning process shall be conducted by randomly selecting 10% of the interior anchor bolts and 10% of the exterior anchor bolts. Testing shall be performed immediately or as soon as practical upon completion initial tensioning. The “E-3 Base Tensioning and 10% Inspection” form shall be completed for every tower base.

10.3.4. Tower Lower Mid, Upper Mid, and Top Erection

The WTG installation may include one or more mid sections and the top section, depending on turbine manufacturer. Each inspection form shall be utilized or modified, as appropriate for the specific manufacturer, prior to the erection of each section. Tower Inspection Forms shall become part of the turnover package to the owner/customer.

10.3.5. Nacelle Erection

The “E-7 Nacelle Pre-Lift Inspection” form shall be utilized or modified as appropriate for the specific manufacturer and completed prior to erection of the nacelle. The “E-8 Nacelle Erection Inspection” form shall be utilized or modified, as appropriate for the specific manufacturer, following erection. The nacelle inspection forms shall become part of the turnover package to the owner/customer.

10.3.6. Rotor Erection

The “E-9 Rotor Assembly Inspection” form shall be utilized or modified as appropriate for the specific manufacturer and completed prior to erection of the rotor. The “E-10 Blade to Hub 10% Inspection” form shall be utilized once the rotor is completely assembled. The “E-11 Rotor Erection Inspection” form shall be utilized or modified as appropriate for the specific manufacturer and completed once the rotor is erected. The rotor inspection forms shall become part of the turnover package to the owner/customer.

10.3.7. Wind Turbine Generator (WTG) 10% Check

The “E-13 WTG 10% Inspection” form shall be utilized or modified as appropriate for the specific manufacturer and completed immediately, or as soon as practical, upon completion of WTG erection. The “E-13 WTG 10% Inspection” form shall become part of the turnover package to the owner/customer.

10.3.8. Wind Turbine Generator Wiring

Prior to WTG wiring, a pre-installation meeting shall be conducted by LFE or designee. A review of the WTG installation manual shall be completed by Company Construction, Inc. management, sub-contractors, and owner/customer. All WTG wiring shall be in accordance with the manufacturer installation manual unless changes have been agreed upon in writing between manufacturer, owner/customer, and Company Construction, Inc..

A calibration certificate is required of all tooling and equipment used for production and 10% checks. All tool calibration certificates shall be turned over to Company Construction, Inc. at the pre-installation meeting. A calibration certificate must be presented and approved by Company Construction, Inc. site management prior to use. Daily inspection of tooling and equipment is mandatory. Tooling calibration certificates shall become part of the turnover package to the owner/customer.

If WTG contains MV cable splices or terminations, Section 11.3.4 “MV Cable Splicing and Terminating” shall be strictly adhered to.

WTG wiring shall follow NESCTM and NECTM standards to guarantee a quality installation.

11. Collection System

11.1. Purpose

The purpose of this section is to establish and delineate the task planning and quality assurance methods and procedures for installation, examination, and testing of electrical cable, equipment, and material during construction installation and pre-commissioning.

11.2. Scope

The following is a summary list of the operations and items for which quality control functions will apply:

- Quality assurance of installation
- Field quality control and testing requirements
- Inspection and testing services
- Manufacturers field services

11.3. Method (Procedure)

The LFE or designee is responsible for the execution of this section. Prior to execution of work, a planning meeting shall be held. At the planning meeting Company Construction, Inc. site management shall review quality control inspections, project specifications, and installation procedures required per engineering and owner/customer requirements.

The design and construction will follow all applicable NESCTM and NECTM standards to guarantee a quality installation. Company Construction, Inc. will have experienced on site QA/QC as well as electrical management for the indicated project.

11.3.1. Subcontractors

Company Construction, Inc. subcontractors shall have a procedure of their own that equals or exceeds this procedure. Prior to execution of work, a planning meeting shall be held. At the planning meeting, the subcontractors shall demonstrate the quality plan that will be followed. Subcontractors shall also provide examples of supporting documentation to verify compliance with the quality plan for the work.

Contractor field, inspection, and test reports shall be furnished to Company Construction, Inc. within the timeframe stated in contract documents. All applicable inspections and test reports shall become part of the turnover package to the owner/customer.

11.3.2. Quality Assurance of Installation

All equipment, materials, products, design, and construction shall be in conformance with contract documents, design drawings, and specifications. All equipment, materials, and products shall be stored per manufacturer's instructions and contract specifications.

Monitor quality control of suppliers and manufacturers of material and equipment and providers of engineering and construction services. Monitor site conditions and workmanship to produce work of specified quality, and comply with all applicable and specified standards, tolerances, codes, or requirements.

Comply fully with manufacturers' installation instructions, including each step in sequence. If the manufacturers' instructions conflict with contract documents, request clarification before proceeding.

11.3.2. Quality Assurance of Installation

(continued)

Perform work using persons qualified to produce workmanship of specified quality.

A thorough inspection shall be performed as required by laws, codes, regulations, or specifications and shall confirm and document that all installations have been reviewed, are complete, and are in conformance with applicable specifications and workmanship requirements.

The design and construction will follow all applicable NESCTM and NECTM standards to guarantee a quality installation.

11.3.3. Medium Voltage, Low Voltage, and Fiber Optic Cable

All incoming MV, LV, and/or DLO and fiber optic cable reels shall be visually inspected for damage upon delivery. Cable manufacturer, serial number, and length shall be recorded on the applicable tracking log. Manufacturer test reports for each cable reel shall be reviewed to ensure it meets project specifications.

MV, LV, or DLO and fiber optic cable shall be tested in accordance with project specifications, established test protocols, and safety requirements.

Each conductor shall be tested individually before making wiring terminal connections and test results recorded on appropriate test form. If specified test values are not met, further testing to isolate the problem may be needed. Company Construction, Inc. management shall be notified immediately of any failed testing. If desired insulation resistance cannot be obtained, new cable shall be installed and tested.

Manufacturer and field test results shall become part of the turnover package to the owner/customer.

11.3.4. MV Cable Splicing and Terminating

It is Company Construction, Inc.'s policy that no individual can perform or assist with MV cable splicing or terminating without completing training sponsored by the manufacturer of the splice or termination kit. MV cable splicing or terminating shall not be conducted until this training has been completed. If an individual has had site specific training conducted by the manufacturer of the splice or termination kit from a previous Company Construction, Inc. project, and the training has been completed within the last 6 months, site specific training may be waived by Company Construction, Inc. management.

All MV splices and terminations are to be installed by carefully following the manufacturer's instructions. Before installing any splice, lug, or terminal, the conductor shall be verified by inspection and by measurement to ensure that the connector matches the conductor size and type. Compression tools and dies must be as recommended by lug or terminal manufacturer. All installations shall be in strict accordance to manufacturer's installation instructions.

A calibration certificate is required of all tooling and equipment used to perform splicing or terminating. A calibration certificate must be presented and approved by Company Construction, Inc. site management prior to use. Daily inspection of tooling and equipment is mandatory.

Qualification certificates for all cable splicer and tooling calibration certificates shall become part of the turnover package to the owner/customer.

11.3.5. Collection System Installation

Prior to underground cable installation, a pre-installation meeting shall be conducted by LFE or designee. A review of the collection system drawings and specifications shall be completed by Company Construction, Inc. management, subcontractors, and owner/customer. Required installation practices shall be discussed, and all applicable quality control inspections, specifications, and drawings shall be reviewed.

11.3.5. Collection System Installation

(continued)

All subcontractors shall submit a detailed cable management plan to the Company Construction, Inc. electrical superintendent prior to beginning underground cable installation operations. The cable management plan shall be reviewed and approved by the Company Construction, Inc. electrical superintendent.

During direct bury cable installation, monitor and inspection shall be conducted throughout installation process. Cable manufacturer installation requirements for bend radius and cable tension will be strictly adhered to. The inspection shall be documented on the cable installation inspection form and included in the turnover package to the owner/customer.

In the event that an underground cable splice, intermediate ground, fiber splice, or directional bore is installed, the applicable inspection form shall be completed. GPS coordinates for underground cable splice, intermediate ground, fiber splice, or directional bore shall be recorded using the project standard GPS datum. GPS coordinates shall be recorded into the project GPS index log and updated on the project as-built drawings. The applicable inspection form shall become part of the turnover package to the owner/customer.

For each junction box, cross bond box, or fiber splice box, the applicable inspection form shall be completed. All GPS coordinates shall be recorded into the project GPS index log and updated on the project as-built drawings. The applicable inspection form shall become part of the turnover package to the owner/customer.

The “C-5 Drain Tile Repair Inspection” form, as appropriate, shall be completed if any drain tile is damaged during construction operations.

11.3.6. Equipment

All incoming transformers or switchgears shall be subject to a receiving inspection upon arrival, utilizing the appropriate receiving inspection form. Equipment identification number or serial number and designation shall be recorded into the appropriate receiving log. Manufacturer's test reports and receiving inspection forms shall become part of the turnover package to the owner/customer.

Transformer or switchgear installation and cable terminations shall be inspected utilizing the transformer or switchgear inspection form. Inspection of cable terminations, torque value, equipment grounding, and nameplate data shall be conducted. Inspection reports shall become part of the turnover package to the owner/customer.

Prior to transformer energization, the electrical superintendent or competent designee shall utilize a Hastings™ Meter, or "Last Chance Meter", to check for proper phasing of low voltage conductors. The transformer energization check list form shall be utilized upon energization to record voltage and phase rotation. The transformer energization check list shall become part of the turnover package to the owner/customer.

11.3.7. Independent Inspection and Testing Services

Perform and document inspection and field testing. Reports will be submitted to Company Construction, Inc. within the time specified, but under no circumstances more than five (5) calendar days of completion, indicating observations and results of tests and indication compliance with contract documents.

Reports indicating non-compliance with contract documents shall be submitted to Company Construction, Inc. within two (2) calendar days of completion. Company Construction, Inc. will compile all reports and submit them to the owner/customer with the final turnover package.

Provide suitable safety precautions and protection per OSHA and NESCTM during field testing. Only trained and qualified personnel shall operate test equipment. Additionally, ground and discharge equipment to make the equipment safe after high potential testing.

11.3.7. Independent Inspection and Testing Services

(continued)

Perform system functional testing after component acceptance testing is complete to verify that all equipment and systems will operate properly. Company Construction, Inc. shall notify owner/customer in advance to allow witnessing.

11.3.8. Manufacturers' Field Services and Reports

If necessary to comply with manufacturers' warranty terms, or if specified in contract documents, arrange for material or equipment suppliers or manufacturers to provide qualified staff personnel (field representative) to perform the following services:

- Observe and document site conditions, conditions of installation, and quality of workmanship.
- Report observations and site decisions or instructions given to applicators or installers that are supplemental or contrary to manufacturers' written instructions.
- Assist with field assembly as required.
- Supply required test equipment.
- Perform and record the results of manufacturer recommended inspections and tests and tests specified for material and equipment following established test protocols.
- Be responsible for protection of material and equipment and safety of all personnel during testing.
- Perform any other services normally recommended or provided by field representative's company.
- Instruct operating personnel in proper use of material, equipment, and systems.
- Instruct, supervise, and validate any required field repairs prior to acceptance by owner/customer.
- Submit reports of activities, actions taken, and test results to Company Construction, Inc. within five (5) calendar days of completion.

12. Substation and/or Interconnect

12.1. Purpose

The purpose of this section is to establish and delineate the task planning and quality assurance methods and procedures for installation, and to establish and delineate the examination and testing of electrical cable, equipment, and material during construction installation and pre-commissioning.

12.2. Scope

The following is a summary list of the operations and items for which quality control functions will apply:

- Quality assurance of installation
- Inspection and testing services
- Manufacturers field services
- Field quality control and testing requirements

12.3. Method (Procedure)

The LFE or designee is responsible for the execution of this section. Prior to execution of work, a planning meeting shall be held. At the planning meeting, Company Construction, Inc. site management shall review quality control inspections, project specifications, and installation procedures required per engineering and owner/customer requirements.

The design and construction will follow all applicable NESCTM and NECTM standards to guarantee a quality installation. Company Construction, Inc. will have experienced on site QA/QC as well as electrical management for the indicated project.

12.3.1. Subcontractors

Company Construction, Inc. subcontractors shall have a procedure of their own that equals or exceeds this procedure. Prior to execution of work, a planning meeting shall be held. At the planning meeting, the subcontractors shall demonstrate the quality plan that will be followed. Subcontractors shall also provide examples of supporting documentation to verify compliance with the quality plan for the work.

Contractor field reports, inspection, and test reports shall be furnished to Company Construction, Inc. within the timeframe stated in contract documents. All applicable inspections and test reports shall become part of the turnover package to the owner/customer.

12.3.2. Quality Assurance and Control of Installation

All equipment, materials, products, design, and construction shall be in conformance with contract documents, design drawings, and specifications. All equipment, materials, and products shall be stored per manufacturer's instructions and contract specifications.

Monitor site conditions and workmanship to ensure work complies with all applicable and specified standards, tolerances, codes, or requirements and is completed per contract drawings, specifications, and specified quality. Monitor quality control of suppliers and manufacturers of material and equipment and providers of engineering and construction services. Monitor site conditions and workmanship to produce work of specified quality.

Comply fully with manufacturers' installation instructions, including each step in sequence. If the manufacturers' instructions conflict with contract documents, request clarification before proceeding.

Perform work using persons qualified to produce workmanship of specified quality.

A thorough inspection shall be performed as required by laws, codes, regulations, or specifications and shall confirm and document that all installations have been reviewed, are complete, and are in conformance with applicable specifications and workmanship requirements, including verification of installation of covers on boxes, fittings, and apparatus and are weather tight if required

Pre-commission energizing of electrical equipment will be conducted only when specified and only with permission from owner/customer and Company Construction, Inc. All LOTO procedures shall be strictly enforced. All applicable inspections and test reports shall become part of the turnover package to the owner/customer.

The design and construction will follow all applicable NESCTM and NECTM standards to guarantee a quality installation.

12.3.3. Receiving

All incoming material, components, and structures shall be subject to a visual inspection upon arrival. All equipment, materials, products, design, and construction shall be in conformance with contract documents, design drawings, and specifications and the requirements of this section. The equipment receiving inspection form shall be utilized upon receipt of large equipment components. The equipment receiving inspection form shall become part of the project turnover package to owner/customer.

12.3.4. Grounding System

A visual and mechanical inspection of grounding system shall be conducted to ensure grounding cable, ground rods, and exothermic or mechanical ground connection(s) are in compliance with engineer drawings and specification. Verify all substation structures, equipment, buildings, switch stands, fencing, and gates are grounded properly. The ground grid inspection form shall be utilized for this inspection.

Substation ground grid shall be tested according to engineer specifications and recommendations. Substation ground grid inspection and test results shall become part of the project turnover package to owner/customer.

12.3.5. Foundations

Foundation excavations shall be visually inspected prior to concrete placement to ensure excavation and reinforcing steel is consistent with design requirements.

An independent testing agency will be utilized to test subgrade compaction. Testing shall be conducted per engineer specifications and owner/customer requirements. The foundation excavation inspection form and subgrade test reports shall become part of the turnover package to the owner/customer.

12.3.6. Mill Certification

A mill certification form shall be provided by the manufacturer at the time of delivery of the anchor bolts, embed rings, and reinforcing steel used on the project. Embedment of these items shall not take place until the mill certifications have been received by Company Construction, Inc. All mill certifications shall be submitted to the structural engineer for approval. The mill certifications shall become part of the turnover package to owner/customer.

12.3.7. Concrete Testing

An independent testing agency will be utilized to sample and test concrete. A record of concrete test specimen results will be provided by the independent testing company using their standard report form. Concrete test cylinders shall be made following the recommendations of the ACI or according to foundation specifications. Cylinders shall be made, handled, and cured in accordance with ASTM C31 and shall be strength tested in accordance with ASTM C39 along with foundation specifications. Test reports shall become part of the turnover package to the owner/customer.

12.3.8. Structure and Equipment Installation

The structure and equipment inspection forms shall be utilized or modified according to project specifications. Forms shall become part of the turnover package to the owner/customer.

12.3.9. Overhead Bus

Aluminum welding shall be conducted by a certified welder. Copies of welding certifications shall be filed. Insulators and bus shall be thoroughly clean prior to energizing per manufacturer's instructions. A final cleaning shall be provided of equipment and the removal of construction debris at associated work area prior to placing system in service. The overhead bus inspection form shall be utilized to complete this inspection. The inspection form shall become part of the turnover package to owner/customer.

12.3.10. Substation/Interconnect Yard

The substation/interconnect yard inspection form shall be utilized for this inspection. An inspection shall be conducted to ensure warning signs, equipment or steel structure labels, fencing/gates, yard lighting, and gravel installation is completed per project design and specifications. The inspection form shall become part of the turnover package to owner/customer.

12.3.11. Large Equipment, Relay, and Control Panels

- Consult manufacturers' instructions for assembly, installation, and testing of equipment following established testing and safety protocols.
- Visually inspect physical and mechanical condition upon delivery.
- Compare equipment nameplate data with drawings and specifications.
- Check for adequate clearances between energized parts and to ground.
- Perform and document point-to-point wire checks of field circuits prior to functional testing.
- Verify proper polarity, phasing, and CT/PT taps of current and voltage inputs.
- Calibrate and program relays and meters per the engineer of record settings and manufacturer's instructions.
- Functionally check control and indication devices by operating the associated equipment.
- Instruct owner/customer operating personnel in proper equipment use if requested.

12.3.12. Independent Inspection and Testing Services

Perform and document inspection and field testing per contract requirements and specifications. Reports will be submitted to Company Construction, Inc. within the time specified, but under no circumstances more than five (5) calendar days of completion, indicating observations and results of tests and indicating compliance with contract documents.

12.3.12. Independent Inspection and Testing Services (continued)

Provide suitable safety precautions and protection per OSHA and NESCTM during field testing. Only trained and qualified personnel shall operate test equipment. Additionally, ground and discharge equipment to make the equipment safe after high potential testing.

Perform system functional testing after component acceptance testing is complete to verify that all equipment and systems will operate properly. Company Construction, Inc. shall notify owner/customer in advance to allow witnessing.

12.3.13. Manufacturers' Field Services and Reports

If necessary to comply with manufacturers' warranty terms, or if specified in contract documents, arrange for material or equipment suppliers or manufacturers to provide qualified staff personnel (field representative) to perform the following services:

- Observe and document site conditions, conditions of installation, and quality of workmanship.
- Report observations and site decisions or instructions given to applicators or installers that are supplemental or contrary to manufacturers' written instructions.
- Assist with field assembly as required.
- Supply required test equipment.
- Perform and record results of manufacturer recommended inspections and tests and tests specified for material and equipment following established test protocols. Be responsible for protection of material, equipment, and safety of all personnel during testing.
- Perform any other services normally recommended or provided by the field representative's company.
- Instruct operating personnel in proper use of material, equipment, and systems.
- Instruct, supervise, and validate any required field repairs prior to acceptance by owner/customer.
- Submit reports of activities, actions taken, and test results to Company Construction, Inc. within five (5) calendar days of completion.

13. Transmission Line

13.1. Purpose

The purpose of this section is to establish project quality assurance methods and procedures for installation, examination, and testing of electrical cable, equipment, and material during construction installation.

13.2. Scope

The following is a summary list of the operations and items for which quality control functions will apply:

- Quality assurance of installation
- Inspection and testing services
- Manufacturers field services
- Field quality control and testing requirements

13.3. Method (Procedure)

The LFE or designee is responsible for the execution of this section. Prior to execution of work, a planning meeting shall be held. At the planning meeting, Company Construction, Inc. site management shall review quality control inspections, project specifications and installation procedures required per engineering, and owner/customer requirements.

The design and construction will follow all applicable NESCTM and NECTM standards to guarantee a quality installation. Company Construction, Inc. will have experienced on site QA/QC and electrical management for the indicated project.

13.3.1. Subcontractors

Company Construction, Inc. subcontractors shall have a procedure of their own that equals or exceeds this procedure. Prior to execution of work, a planning meeting shall be held. At the planning meeting, the subcontractors shall demonstrate the quality plan that will be followed. Subcontractors shall also provide examples of supporting documentation to verify compliance with the quality plan for the work.

Contractor field, inspection, and test reports shall be furnished to Company Construction, Inc. within the timeframe stated in contract documents. All applicable inspections and test reports shall become part of the turnover package to the owner/customer.

13.3.2. Quality Assurance and Control of Installation

All equipment, materials, products, design, and construction shall be in conformance with contract documents, design drawings, and specifications. All equipment, materials, and products shall be stored per manufacturer's instructions and contract specifications.

Monitor site conditions and workmanship to ensure work complies with all applicable and specified standards, tolerances, codes, or requirements and is completed per contract drawings, specifications, and specified quality.

Monitor quality control of suppliers and manufacturers of material and equipment and providers of engineering and construction services. Monitor site conditions and workmanship to produce work of specified quality.

Comply fully with manufacturers' installation instructions, including each step in sequence. If manufacturers' instructions conflict with contract documents, request clarification before proceeding.

Perform work using persons qualified to produce workmanship of specified quality.

A thorough inspection shall be performed as required by laws, codes, regulations, or specifications and shall confirm and document that all installations have been reviewed, are complete, and are in conformance with applicable specifications and workmanship requirements.

The design and construction will follow all applicable NESCTM and NECTM standards to guarantee a quality installation.

13.3.3. Receiving

All incoming material, components, and structures shall be subject to a visual inspection upon arrival. All equipment, materials, products, design, and construction shall be in conformance with contract documents, design drawings, and specifications and the requirements of this section. Material and equipment shall be stored and protected prior to installation per manufacturer's instructions. The equipment receiving inspection form shall be utilized upon receipt of large equipment components. The equipment receiving inspection form shall become part of the project turnover package to owner/customer.

13.3.4. Grounding

A visual and mechanical inspection of the grounding system shall be conducted to ensure grounding cable, ground rods, and exothermic or mechanical ground connection(s) are in compliance with engineer drawings and specification.

Structure grounding shall be tested according to engineer specifications and recommendations. The structure ground test reports shall become part of the project turnover package to owner/customer.

13.3.5. Foundations

Foundation excavations shall be visually inspected prior to concrete placement to ensure excavation and reinforcing steel is consistent with design specifications. The structure inspection (concrete foundation) form shall be completed prior to concrete placement. The structure inspection (concrete inspection) form and subgrade test reports shall become part of the turnover package to the owner/customer.

13.3.6. Mill Certification

A mill certification form shall be provided by the manufacturer at the time of delivery of the anchor bolts, embed rings, and reinforcing steel used on the project. Embedment of these items shall not take place until the mill certifications have been received by Company Construction, Inc.. All mill certifications shall be submitted to the structural engineer for approval. The mill certifications shall become part of the turnover package to owner/customer.

13.3.7. Concrete Testing

An independent testing agency will be utilized to sample and test concrete. A record of concrete test specimen results will be provided by the independent testing company using their standard report form. Concrete test cylinders shall be made following the recommendations of the ACI or according to foundation specifications. Cylinders shall be made, handled, and cured in accordance with ASTM C31 and shall be strength tested in accordance with ASTM C39 along with the foundation specifications. Test reports shall become part of the turnover package to the owner/customer.

14. Operation and Maintenance Building

14.1. Purpose

The purpose of this section is to establish and delineate the task planning and quality assurance methods and procedures to be used for the testing, examination, and inspection of the operation and maintenance building (O&M) construction applications.

14.2. Scope

The following is a summary list of the operations and items for which quality control functions will apply:

- Critical permits
- Inspections and testing
- Concrete
- Structural
- Mechanical and electrical

14.3. Method

The LFE or designee is responsible for the execution of this section. The Company Construction, Inc. subcontractor shall have a procedure of their own that equals or exceeds this procedure. Prior to execution of work, a planning meeting shall be held. At the planning meeting, the subcontractors shall demonstrate the quality plan that will be followed. Subcontractors shall also provide examples of supporting documentation to verify compliance with the quality plan for the work.

A survey control system for those items deemed necessary by Company Construction, Inc. shall be established, and baselines/benchmarks shall be located on-site. As deemed appropriate by Company Construction, Inc., survey work performed by or for subcontractors may be independently verified by an independent professional surveyor provided by Company Construction, Inc..

The owner/customer shall be responsible to provide the precise location of O&M building. Company Construction, Inc. shall obtain owner/customer approval of the physical location of O&M building prior to beginning work at location.

The following is a summary list of the operations and items for which quality control functions will apply:

- Foundation construction
- Foundation backfill
- Plumbing installation
- HVAC installation
- Electrical installation
- Architectural installation

15. Measuring and Test Equipment

15.1. Purpose

The purpose of this section is to ensure that the testing and measurement equipment provides accurate results of tests or measurements performed.

15.2. Scope

This procedure covers all measuring and testing equipment used by Company Construction, Inc. and Company Construction, Inc. subcontractors' measurement to accept or reject work or products.

15.3. Method

Company Construction, Inc. LFE or designee is responsible for the execution of this procedure.

Company Construction, Inc. and its subcontractors shall determine the necessary measuring and testing equipment based on applicable testing standards, on usual and customary industry practice, and the measurement and testing requirements of the contract documents.

All measuring and testing equipment shall be calibrated in accordance with applicable testing standards and equipment manufacturer recommendations.

- Use standards which are traceable to national standards.
- Have appropriate re-calibration intervals.
- Employ the use of a sticker or other means necessary that indicates the next re-calibration date of the measuring or testing equipment
- All calibration certificates associated with site tooling shall be filed on site. An electronic copy shall be stored by Company Construction, Inc. management for future reference.

All measuring and testing equipment shall be identified and stored in a suitable manner to protect from damage or distortion.

Prior to use, the date of last calibration is to be verified by FE or designee. In those instances where contract documents require additional measures, the measure specified, or its approved equivalents, are to be followed. Additionally, if the accuracy of the instrument is suspect for any reason, the instrument shall not be used until proper calibration is confirmed.

15.3.1. Company Construction, Inc. Testing

All testing required in the specifications shall be conducted and documented per contract requirements. Testing is performed for compliance and the integrity of the work performed. Test reports shall be completed by the FE directly responsible for the work performed. All testing reports that fail project testing specifications shall not be accepted. The FE directly responsible for the testing performed shall initiate a non-conformance report. All non-conformance reporting procedures shall be followed.

15.3.2. Third Party Testing

Third party testing is performed to increase the level of accountability and meet engineer or owner/customer requirements. Third party testing shall be coordinated directly by the FE responsible for the testing performed. The FE directly responsible for the testing performed shall review and approve all reports for acceptance. Third party testing reports that fail project testing specification shall not be accepted. The FE directly responsible for the testing performed shall initiate a non-conformance report. All non-conformance reporting procedures shall be followed.

16. Non-Conformance/Corrective and Preventative Action

16.1. Purpose

The purpose of this section is to ensure that work including supplied components which do not conform to the contract documents requirements is prevented from use or installation.

An additional purpose of this section is to ensure that corrective and preventative action is taken to eliminate the root cause(s) of non-conformance.

16.2. Scope

The scope of this section covers all work and/or equipment installed during the construction phase of the project. All project activities affecting quality are covered by this procedure.

16.3. Method (Procedure)

The LFE or designee is responsible for the execution of this procedure.

In planning work, prior experience, associated lessons learned, and other resources, such as co-workers and historical non-compliance reports, shall be employed to identify and prevent potential non-conformance.

16.3. Method (Procedure)

(continued)

Non-conforming work or components discovered during inspections or tests shall be recorded on the non-conformance report.

Work or components which are deemed non-compliant shall be identified by the placement of a red tag on the work or component, indicating that it is non-compliant and may not be used.

16.3.1. External Non-Conformance

For external (non-company) non-conformance issues, a copy of the non-conformance report shall be distributed to the customer and to the party responsible for the non-compliant item(s). The non-conformance report shall direct the party responsible for the non-compliant item(s) to submit immediately a plan of action for correcting the item along with a schedule indicating when the work will be complete.

16.3.2. Internal Non-Conformance

For internal (company) non-conformance issues, a copy of the non-conformance report shall be distributed to the LFE, FE, foreman, and superintendent responsible for the work. An information copy shall also be distributed to the PM and general superintendent. The LFE shall be responsible for the determination of the proper course of action, for the resolution of the issue, and for communicating the solution to all applicable parties.

Upon execution of the resolution, the foreman responsible for execution of the resolution shall provide notice to the FE responsible for the work. The FE shall inspect the corrective action taken and close the non-conformance issue at such a time as the work passes inspection. The FE shall provide notice to all applicable parties when the corrective action is compliant with applicable specifications. The FE shall sponsor a meeting with the parties involved with the non-compliant work to determine the root cause of the issue.

The FE shall be responsible for distributing a "Lessons Learned" memo indicating the issue, the root cause, the solution, and the means for prevention of a reoccurrence to the director of project management and safety and quality.

16.3.3. Repair or Replacement of Non-Compliant Item(s)

At such time as the repair or replacement of the non-compliant item(s) is complete, measurements, tests, and inspections shall be performed to determine if the item(s) are compliant with the applicable requirements. At such time as the result of this work is complete and the item(s) are in fact compliant, they shall be approved for incorporation into the work.

17. Control of Quality Documentation

17.1. Purpose

The purpose of this section is to provide a method for identification, collection, accessing, filing, storage, maintenance, and disposition of quality records. These records are maintained to demonstrate conformance to contract document requirements and the effective operation of the wind energy quality control plan. Additionally, the purpose is to provide a method of preparing the turnover packages required by contract, a major portion of which will be quality records.

17.2. Scope

All Company quality records and turnover packages defined by contract are covered by this procedure. Pertinent subcontractor quality records and supplier/other data shall be components of these records and packages

17.3. Method (Procedure)

All site related quality inspections, test reports, qualifications, etc. will be submitted to the LFE for review. The LFE will review the documents for errors, content, and neatness. If the document is reviewed and proven to be incomplete or incorrect, the document will be re-issued to the submitting party for correction and re-submission. Once the LFE reviews the document as acceptable, the document will be scanned and filed by the site administrator. A hard copy and an electronic copy will be filed on site. The copies will be stored in books/files relating to the turbine associated with the document or to the area of work associated, i.e. civil, substation, collection, O&M building, etc. The documents will also be tracked on a log which is utilized to track what documents have been submitted and what documents are outstanding.

17.3.1. Turnover Package Items

Turnover packages shall include, but is not limited to, the following information:

- Technical information for the work that was performed.
- Company quality control inspections
- Subcontractor inspections
- Manufacturer test reports
- Field test reports
- Third party inspections and test reports
- Personnel qualification records
- Material traceability records, if required
- Product data information
- Other documents applicable to the quality of the project

17.3.2. Turnover Book

Project turnover books are designed to aid in the organization of the turnover packages. There are many different parts of a project that will require a turnover book. Depending on the size of the project and scope of work, the indicated project may contain the following turnover book(s):

- Civil/roads
- Wind turbine generator (WTG)
- Collection system
- Substation and/or interconnect
- Transmission line
- Other, if applicable

Appendix A: Quality Control Inspections

General Notes:

If applicable, the following inspection forms shall be utilized or modified as appropriate for the indicated project.

If the subcontractor or the owner/customer provide documentation for similar inspection, use the subcontractor or owner/customer documentation. If possible or needed, add additional required company information to the provided inspection form.

Form of Job Books

The form of job books provides a table of contents view of the typical inspections and tests that are performed and documented to assure quality of construction. Inspections may be deleted, added, or modified based on project specifics.

The below list shows what the job books will look like and what will be contained in them. The contents and order may change in order to make them project specific.

1. Civil Construction Book

Table B: Civil Construction Book

| | |
|----|---|
| 1a | C-01 Construction Period Road Inspection |
| 1b | Third Party Proof Roll Test Results |
| 1c | Third Party Density Results |
| 1d | C-03 Crane Pad Inspection |
| 1e | Third Party Proof Roll Test Results |
| 1f | Third Party Density Results |
| 1g | C-05 Seeding Inspection |
| 1h | C-06 WTG Site and Road Restoration Inspection |
| 1i | C-07 Intersection Modification |
| 1j | C-08 Approach/Temporary Radius |
| 1k | C-09 Intersection Modification Restoration |
| 1l | C-10 Yard Subgrade and Gravel Placement |
| 1m | Punch Lists |

2. WTG Books

Table C: WTG Book

| | |
|----------|--|
| 1 | WTG Foundation Material Receiving Inspections |
| 1a | FR-1 Template Ring Receiving Inspection |
| 1b | FR-2 Embedment Ring Receiving Inspection |
| 1c | FR-3 Anchor Bolt and Hardware Receiving Inspection |
| 1d | FR-4 Pedestal Form Receiving Inspection |
| 1e | FR-6 Anchor Bolt Cage Data |
| 2 | WTG Foundation Documents |
| 2a | F-1 Foundation Excavation Inspection |
| 2b | Third Party Subgrade Acceptance Report |
| 2c | F-2 Mud Mat Inspection |
| 2d | F-3 Bottom Mat Inspection |
| 2e | F-4 Anchor Bolt Cage Inspection |
| 2f | F-5 Top Mat Inspection |
| 2g | F-6 Pedestal Rebar and Conduit Pre-Pour Inspection |
| 2h | F-7 Pre-Pour and Form Inspection |
| 2i | F-8 Concrete Placement Inspection |
| 2j | Third Party Concrete Field Test Summary Report |
| 2k | Third Party Concrete Break Results |
| 2l | F-9 Foundation Grounding and Pre-Backfill Inspection |
| 2m | F-10 Foundation Backfill Inspection |
| 2n | Third Party Foundation Backfill Compaction Results |
| 2o | Foundation Ground Grid Performance Test Results |
| 3 | WTG Foundation Material Certificates |
| 3a | Reinforcing Steel Mill Certificates |
| 3b | Anchor Bolt Mill Certificates |
| 3c | Embedment Ring Mill Certificate |
| 3d | Mud Mat Concrete Tickets |
| 3e | Foundation Concrete Tickets |

2. WTG Books
(continued)

Table C: WTG Books (continued)

| | |
|----------|---|
| 4 | WTG Component Receiving Documents |
| 4a | R-1 Power Unit Receiving Inspection |
| 4b | R-2 Tower Section Receiving Inspection (Base) |
| 4c | R-2 Tower Section Receiving Inspection (Mid) |
| 4d | R-2 Tower Section Receiving Inspection (Top) |
| 4e | R-3 Nacelle Receiving Inspection |
| 4f | R-4 Hub Receiving Inspection |
| 4g | R-5 Blade Receiving Inspection (1) |
| 4h | R-5 Blade Receiving Inspection (2) |
| 4i | R-5 Blade Receiving Inspection (3) |
| 5 | WTG Installation Documents |
| 5a | E-1 Mounting of Power Unit |
| 5b | E-2 Base Erection Inspection |
| 5c | E-3 Grout Placement Inspection |
| 5d | Third Party Grout Break Results |
| 5e | E-4 Base Tensioning and 10% Inspection |
| 5f | E-5 Mid Erection Inspection |
| 5g | E-6 Top Erection Inspection |
| 5h | E-7 Nacelle Prep Inspection |
| 5i | E-8 Nacelle Pre-Lift Inspection |
| 5j | E-9 Nacelle Erection Inspection |
| 5k | E-10 Rotor Assembly Inspection |
| 5l | E-11 Blade to Hub Tensioning and 10% Inspection |
| 5m | E-12 Rotor Erection Inspection |
| 5n | E-13 WTG Torque Form |
| 5o | E-14 WTG 10% Inspection |
| 5p | FAA Lights Manual, If Applicable |
| 5q | Fall Arrest System Manual/Checklist, If Applicable |
| 5r | Climb Assist Commissioning/Inspection Report, If Applicable |
| 6 | Completion Certificates |
| 6a | Foundation Completion Certificate |
| 6b | Turbine Supplier Installation Checklist |
| 6c | Walk Down Punch List |
| 6d | WTG Mechanical Completion |

3. Collection (Feeder) Book

Table D: Collection (Feeder) Book

| | Feeder (A) |
|----|---|
| A1 | Cable Installation Summary |
| | CS-9 Cable Installation Inspections |
| A2 | Junction/Splice Box Log |
| | CS-11 Junction Box Inspections |
| A3 | Cable Splice Log |
| | CS-12 Cable Splice Inspection |
| A4 | Fiber Splice Log |
| | CS-15 Fiber Splice Inspections |
| A5 | Directional Bore |
| | CS-16 Directional Boring Inspections |
| | Feeder (B) |
| B1 | Cable Installation Summary |
| | CS-9 Cable Installation Inspections |
| B2 | Junction/Splice Box Log |
| | CS-11 Junction Box Inspections |
| B3 | Cable Splice Log |
| | CS-12 Cable Splice Inspection |
| B4 | Fiber Splice Log |
| | CS-15 Fiber Splice Inspections |
| B5 | Directional Bore |
| | CS-16 Directional Boring Inspections |
| | Continued as applicable for the number of Feeders |

4. Collection (Tower) Book

Table E: Collection (Tower) Book

| | |
|----|--|
| 1 | CS-1 Box Pad Inspections |
| 2 | CS-2 Transformer Receiving Inspections |
| 3 | CS-3 Transformer Inspections |
| 4 | CS-5 Transformer Energization Check Lists |
| 5 | Collection System Cable Management Log |
| 6 | CEI Total Placed Cable Log |
| 7 | CEI Daily Plow Logs |
| 8 | CEI Directional Bore Log |
| 9 | Collection System Progress Report |
| 10 | Collection System MV Cable and Transformer Receiving Log |
| 11 | MV Cable Manufacturer Certified Test Reports |
| 12 | MV Cable Megger Test Results on Reel |
| 13 | MV Cable PD Test Results Installed |
| 14 | Fiber Optic Manufacturer Certified Test Reports |
| 15 | Fiber Optic OTDR Test Results on Reel |
| 16 | Fiber Optic OTDR Test Results Installed |
| 17 | Miscellaneous Collection System Documents |

5. Substation Book

Table F: Substation Book

| | |
|----------|--|
| 1 | Grounding |
| 1a | S-1 Ground Grid Inspection |
| 1b | Ground Grid Resistivity Test Results |
| 2 | Conduit |
| 2a | S-2 Conduit Inspection |
| 2b | S-4 Cable Trenwa Inspection |
| 3 | Foundation Documents |
| 3a | S-3 Foundation Inspection |
| 3b | Third Party Subgrade Compaction Test Results |
| 3c | Reinforcing Steel Mill Certificates |
| 3d | Anchor Bolts Mill Certificates |
| 3e | Embedment Ring Mill Certificates |
| 3f | Concrete Tickets |
| 3g | Third Party Concrete Break Test Results |
| 4 | Equipment |
| 4a | S-5 Equipment Receiving Inspection |
| 4b | S-6 Equipment Inspection |
| 5 | Structures |
| 5a | S-7 Structure Inspection |
| 5b | Steel Mill Certificates |
| 6 | Overhead Bus |
| 6a | S-8 Overhead Bus Inspection |
| 6b | Aluminum Bus Welding Certificates |
| 6c | Manufacturer Certified Test Report |
| 7 | Control Building |
| 7a | S-9 Control Building Inspection |
| 8 | Substation Yard |
| 8a | S-10 Substation Yard Inspection |

5. Substation Book
(continued)

Table F: Substation Book (continued)

| | |
|----------|--|
| 9 | Field Test Results |
| 9a | SF6 Gas Sample Test Results |
| 9b | Step Voltage Test Results: Circuit Integrity Testing |
| 9c | 34.5 kV Breaker Test Results |
| 9d | 34.5 kV Switch Test Results |
| 9e | HV Breaker Test Results |
| 9f | HV Switch Test Results |
| 9g | HV Metering Test Results |
| 9h | Control Building Battery Test Results |
| 9i | Main Power Transformer Test Results |
| 9j | Protective Relay Test Results |
| 9k | Energization Test Results |
| 9l | Medium Voltage Cable Field Test Reports |
| 9m | Fiber Optic Field Test Reports |
| | Appendix A: Material and Equipment |
| | Equipment Specifications and Information |
| | Manufacturer Certified Test Report |
| | Equipment Instruction Manuals |
| | Equipment Warranty Information |
| | Material Product Data |
| | Appendix B: Permits and Drawings |
| | Permits |
| | Design Drawings |

6. Interconnect*Table G: Interconnect*

| | |
|----------|--|
| 1 | Grounding |
| 1a | S-1 Ground Grid Inspection |
| 1b | Ground Grid Resistivity Test Results |
| 2 | Conduit |
| 2a | S-2 Conduit Inspection |
| 2b | S-4 Cable Trenwa Inspection |
| 3 | Foundation Documents |
| 3a | S-3 Foundation Inspection |
| 3b | Third Party Subgrade Compaction Test Results |
| 3c | Reinforcing Steel Mill Certificates |
| 3d | Anchor Bolts Mill Certificates |
| 3e | Embedment Ring Mill Certificates |
| 3f | Concrete Tickets |
| 3g | Third Party Concrete Break Test Results |
| 4 | Equipment |
| 4a | S-5 Equipment Receiving Inspection |
| 4b | S-6 Equipment Inspection |
| 5 | Structures |
| 5a | S-7 Structure Inspection |
| 5b | Steel Mill Certificates |
| 6 | Overhead Bus |
| 6a | S-8 Overhead Bus Inspection |
| 6b | Aluminum Bus Welding Certificates |
| 6c | Manufacturer Certified Test Report |
| 7 | Control Building |
| 7a | S-9 Control Building Inspection |
| 8 | Substation Yard |
| 8a | S-10 Substation Yard Inspection |

6. Interconnect (continued)

Table G: Interconnect (continued)

| | |
|----------|---|
| 9 | Field Test Results |
| 9a | SF6 Gas Sample Test Results |
| 9b | Step Voltage Test Results - Circuit Integrity Testing |
| 9c | 34.5 kV Breaker Test Results |
| 9d | 34.5 kV Switch Test Results |
| 9e | HV Breaker Test Results |
| 9f | HV Switch Test Results |
| 9g | HV Metering Test Results |
| 9h | Control Building Battery Test Results |
| 9i | Main Power Transformer Test Results |
| 9j | Protective Relay Test Results |
| 9k | Energization Test Results |
| 9l | Medium Voltage Cable Field Test Reports |
| 9m | Fiber Optic Field Test Reports |
| | Appendix A: Material and Equipment |
| | Equipment Specifications & Information |
| | Manufacturer Certified Test Report |
| | Equipment Instruction Manuals |
| | Equipment Warranty Information |
| | Material Product Data |
| | Design Drawings |

7. Transmission Line Book

Table H: Transmission Line Book

| | |
|-------|--|
| TL-1 | Structure Inspection (Direct Embed) |
| TL-2 | Structure Inspection (Concrete Foundation) |
| TL-3 | Structure Guying Inspection |
| TL-4 | Transmission Line Inspection |
| TL-5 | Misc. Equipment Receiving Inspection |
| App A | Transmission Line Test Reports |

8. O&M Book

Table 1: O&M Book

| | |
|-------|------------------------------------|
| OM-1 | Critical Plan Approval Check List |
| OM-2 | Third Party Inspection and Testing |
| OM-3 | Footing and Column Pad Inspection |
| OM-4 | Foundation Walls Inspection |
| OM-5 | Backfill Inspection |
| OM-6 | Plumbing Inspection |
| OM-7 | Slab on Grade Inspection |
| OM-8 | Structural Inspection |
| OM-9 | Architectural Inspection |
| OM-10 | Mechanical & Electrical Inspection |

Inspection and Test Plan: Civil Inspections

The “Inspections and Test Plan” section provides an example of a full inspection and test plan for “Civil Construction Block” in the form of job books. A similarly detailed inspection and test plan exists for each section of the form of job books.

1. Civil Inspections

| | |
|------|--|
| C-1 | Construction Period Road Inspection |
| C-2a | Initial Drainage Structure Inspection |
| C-2b | Final Drainage Structure Inspection |
| C-3 | Crane Pad Inspection |
| C-4 | Drain Tile Repair Inspection |
| C-5 | Seeding Inspection |
| C-6 | WTG Site and Road Restoration Inspection |
| C-7 | Intersection Modification |
| C-8 | Approach/Temporary Radius |
| C-9 | Intersection Modification Restoration |
| C-10 | Yard Subgrade and Gravel Placement |

Inspection and Test Plan: Civil Inspections

TBD Wind Energy Project

C-1 Construction Period Road Inspection

0

Road Name or Identifier: _____ Road Length _____ ft.

Drawing #: _____

Subgrade Preparation

Inspection Compliance

| | | |
|--|-----|----|
| 1. Topsoil removed per drawings. | Yes | No |
| 2. Subgrade prepared per drawing and specifications. | Yes | No |
| 3. Subgrade passed proof roll testing. | Yes | No |
| 4. Third party proof roll and subgrade testing data collected and filed. | Yes | No |
| 5. SWPPP installed per drawings and specifications. | Yes | No |

Road Base Installation

| | | | |
|---|-----|-----|----|
| 6. Geotextile fabric installed per drawings and specifications. | Yes | N/A | No |
| 7. Road base passed proof roll testing. | Yes | | No |
| 8. Road shoulders passed proof roll test (both sides). | Yes | N/A | No |

Road Specifications

Gravel Design Width: _____ft. Gravel Design Thickness: _____in. Compacted Shoulder Width: _____ft.

Side to side Max Grade: _____in. Maximum in 100' Crest: _____in. Maximum in 100' Sag: _____in.

| # | Station or GPS Location: | Actual Gravel Width (ft.): | Actual Shoulder-to-Shoulder-Width (ft.): | Actual Gravel Thickness (ft.): | Shoulder-to-Shoulder Elevation Difference (in.): | Actual Side-to-Side Slope: % |
|---|--------------------------|----------------------------|--|--------------------------------|--|------------------------------|
| 1 | | | | | | |
| 2 | | | | | | |
| 3 | | | | | | |
| 4 | | | | | | |
| 5 | | | | | | |
| 6 | | | | | | |
| 7 | | | | | | |
| 8 | | | | | | |

Road Checks shall be performed at a minimum every 500'. If needed, use additional sheets.

Inspection Compliance

| | | |
|---|-----|--------|
| 9. Road width and thickness installed per design tolerances. | Yes | No |
| 10. Road section incline grade less than ____% grade per specifications. | Yes | No |
| 11. Road section maximum side-to-side grade within specifications. | Yes | No |
| 12. Maximum vertical crest in any 100' section within specifications. (____inches) | Yes | No |
| 13. Maximum vertical sag in any 100' section within specifications. (____inches) | Yes | No |
| 14. Were there any Non-Conformance Reports filed? | Yes | No |
| If yes, list NCR #____. Has it been resolved? | Yes | N/A No |

Inspection and Test Plan: Civil Inspections

C-1 Construction Period Road Inspection

Photos

***Representative will do a drive-thru inspection and a completion certificate for each section of road will be issued at the end of the project.*
Note any deviations in the comments section.**

Comments:

Civil Foreman: _____ Date: _____

QA/QC: _____ Date: _____

Inspection and Test Plan: Civil Inspections

TBD Wind Energy Project

C-2a Initial Drainage Structure Inspection

0

Road Name or Identifier: _____ Road Length _____ ft.

Drawing #: _____

Subgrade Preparation

Inspection Compliance

- | | | | |
|--|------------------------------|-----|--------|
| 1. Topsoil removed per drawings. | | Yes | No |
| 2. Subgrade stabilization prepared per drawing and specifications. | | Yes | N/A No |
| 3. Moisture data collected prior to stabilization. | Soil Moisture %: _____ | Yes | N/A No |
| 4. Percent of stabilization: _____% | Type of Stabilization: _____ | | |
| 5. Stabilized Subgrade passed proof roll testing. | | Yes | No |
| 6. Third party proof roll and subgrade testing data collected and filed. | | Yes | No |
| 7. SWPPP installed per drawings and specifications. | | Yes | No |

Road Base Installation

- | | | | |
|---|--|-----|--------|
| 8. Geotextile fabric installed per drawings and specifications. | | Yes | N/A No |
| 9. Road base passed proof roll testing. | | Yes | No |
| 10. Road shoulders passed proof roll test (both sides). | | Yes | N/A No |

Road Specifications

Gravel Design Width: _____ft. Gravel Design Thickness: _____in. Compacted Shoulder Width: _____ft.

Side to side Max Grade: _____in. Maximum in 100' Crest: _____in. Maximum in 100' Sag: _____in.

| # | Station or GPS Location: | Actual Gravel Width (ft.): | Actual Shoulder-to-Shoulder-Width (ft.): | Actual Gravel Thickness (ft.): | Shoulder-to-Shoulder Elevation Difference (in.): | Actual Side-to-Side Slope: % |
|---|--------------------------|----------------------------|--|--------------------------------|--|------------------------------|
| 1 | | | | | | |
| 2 | | | | | | |
| 3 | | | | | | |
| 4 | | | | | | |
| 5 | | | | | | |
| 6 | | | | | | |
| 7 | | | | | | |
| 8 | | | | | | |

Road Checks shall be performed at a minimum every 500'. If needed, use additional sheets

- | | | | |
|--|--|-------------------------------------|--------|
| | | <u>Inspection Compliance</u> | |
| 11. Road width and thickness installed per design tolerances. | | Yes | No |
| 12. Road section incline grade less than _____% grade per specifications. | | Yes | No |
| 13. Road section maximum side-to-side grade within specifications. | | Yes | No |
| 14. Maximum vertical crest in any 100' section within specifications. (_____inches) | | Yes | No |
| 15. Maximum vertical sag in any 100' section within specifications. (_____inches) | | Yes | No |
| 16. Were there any Non-Conformance Reports filed? | | Yes | No |
| If yes, list NCR #____. Has it been resolved? | | Yes | N/A No |

Inspection and Test Plan: Civil Inspections

C-2a Initial Drainage Structure Inspection

Photos

***Representative will do a drive-thru inspection and a completion certificate for each section of road will be issued at the end of the project.*
Note any deviations in the comments section.**

Comments:

Civil Foreman: _____ Date: _____

QA/QC: _____ Date: _____

Inspection and Test Plan: Civil Inspections

TBD Wind Energy Project

C-2b Final Drainage Structure Inspection

0

Structure(s) Identification: _____

Drawing #: _____

Location of Structure: _____

Type of Structure: CMP RCP Other: _____

Number of Structures: _____ Structure Width: _____ Structure Length: _____

Direction of Drain From: _____ Direction of Drain To: _____

Difference in Elevation End to End: _____

Inspection Compliance

| | | | |
|---|-----|-----|----|
| 1. Culvert has not been damaged during construction activities. | Yes | | No |
| 2. If drainage structure is to be placed in county or state ROW, applicable permits have been reviewed and complied with. | Yes | N/A | No |
| 3. Sides and bottom of excavation are consistent with design and manufacturer specs. | Yes | | No |
| 4. Excavation has been cleaned of all loose debris. | Yes | | No |
| 5. Structure width and length per design specifications. | Yes | | No |
| 6. Bedding material added per specifications. | Yes | N/A | No |
| 7. Coupling bands installed and tightened. | Yes | N/A | No |
| 8. Inlet and Outlet meets existing grade or design requirements and design requirements of >1% slope. | Yes | | No |
| 9. Fill meets existing road grade and manufacturers specifications: no humps or dips. | Yes | | No |
| 10. End sections installed per design specifications. | Yes | N/A | No |
| 11. SWPPP installed per drawings and specifications: silt fence, rip rap, etc. | Yes | | No |
| 12. Drainage Structure installed per drawings and specifications. | Yes | | No |
| 13. Actual amount of cover _____ inches over culvert. | Yes | | No |
| 14. Were there any Non-Conformance Reports filed? | Yes | | No |
| If yes, list NCR #____. Has it been resolved? | Yes | N/A | No |

Inspection and Test Plan: Civil Inspections

C-2b Final Drainage Structure Inspection

Photos

Note any deviations in the comments section.

Comments:

Civil Foreman: _____ Date: _____

QA/QC: _____ Date: _____

Inspection and Test Plan: Civil Inspections

TBD Wind Energy Project

C-3 Crane Pad Inspection

0

WTG #: _____

Drawing #: _____

Date: _____

Inspection Compliance

- | | | |
|---|-----|----|
| 1. Location of crane pad per design drawings and reviewed by initialed Superintendents. | Yes | No |
| 2. Backfill compaction report has been reviewed and specifications have been met. | Yes | No |
| 3. All unsuitable material removed from crane pad footprint. | Yes | No |

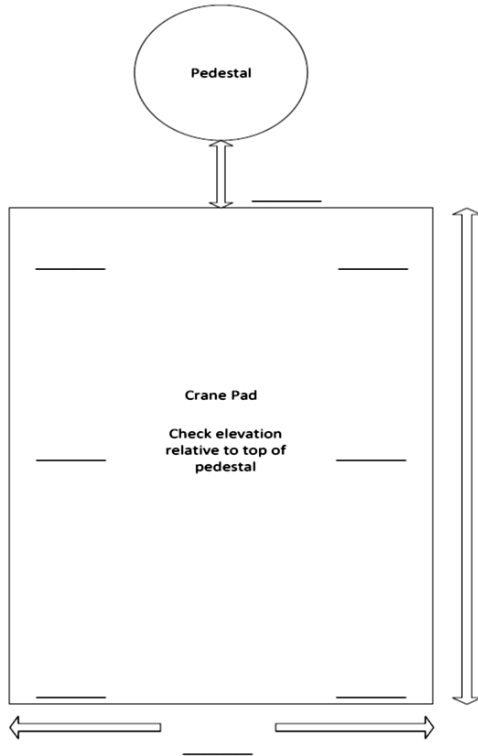

| Crane Pad Specifications | | |
|---|---------------|---------------------------------|
| Measurements | Design | Actual |
| Length: | | |
| Width: | | |
| Maximum out of level value: <1% | | Actual Difference: (in.) |
| Measurements | Design | |
| Front/Back: _____% | < 1% | |
| Side/Side: _____% | < 1% | |
| Corner/Corner: _____% | < 1% | |
| Corner/Corner: _____% | < 1% | |

- | | | |
|--|-----|----|
| 4. Length and width of crane pad within design specifications. | Yes | No |
| 5. Distance from front of crane pad to edge of pedestal per design specifications. | Yes | No |
| 6. Relative height of the crane pad to the turbine pedestal within tolerances. | Yes | No |
| 7. Crane pad level within tolerances. | Yes | No |
| 8. Subgrade compacted per drawings and specifications. | Yes | No |
| 9. Crane pad base passed density testing or proof roll testing. | Yes | No |

Type of subgrade test:

10. Proof Roll DCP Test Other: _____

| | | |
|---|-----|----|
| 11. Verify that water will not pond on crane pad. | Yes | No |
|---|-----|----|

| | | |
|---|-----|----|
| 12. Were there any Non-Conformance Reports filed? | Yes | No |
|---|-----|----|

| | | | |
|---|-----|-----|----|
| If yes, list NCR #____. Has it been resolved? | Yes | N/A | No |
|---|-----|-----|----|

Inspection and Test Plan: Civil Inspections

C-3 Crane Pad Inspection

Photos

Note any deviations in the comments section.

Comments:

Civil Foreman: _____ Date: _____

Erection Superintendent: _____ Date: _____

QA/QC: _____ Date: _____

Inspection and Test Plan: Civil Inspections

TBD Wind Energy Project

C-4 Drain Tile Repair Inspection

0

Date: _____

GPS Datum Used: _____

Drain Tile ID: _____

Property Owner: _____

Tenant (if applicable): _____

GPS Location

Latitude #1: _____ Latitude #2: _____

Longitude: _____ Longitude: _____

Existing Drain Tile Type: Clay Corrugated Plastic Concrete PVC
 Other Description: _____

Replacement Tile Type: Clay Corrugated Plastic Concrete PVC
 Other Description: _____

Repaired Drain Tile Length: _____ Drain Tile Diameter: _____

Location of Damaged Tile: _____

Company Responsible for Repairing Damaged Tile: _____

Date Tile Was Repaired: _____

Inspection Compliance

| | | |
|---|-----|--------|
| 1. Drain tile repaired properly. | Yes | No |
| 2. Photograph(s) taken of completed repair and filed in appropriate file. | Yes | No |
| 3. Land Owner willing to sign off on repair. | Yes | No |
| 4. Were there any Non-Conformance Reports filed? | Yes | No |
| If yes, list NCR # _____. Has it been resolved? | Yes | N/A No |

Inspection and Test Plan: Civil Inspections

C-4 Drain Tile Repair Inspection

Photos

Note any deviations in the comments section.

Comments:

Civil Foreman: _____ Date: _____

Landowner/Representative: _____ Date: _____

QA/QC: _____ Date: _____

Inspection and Test Plan: Civil Inspections

TBD Wind Energy Project

C-5 Seeding Inspection

0

Date of Seeding: _____

Seeding Locations: _____

Type of Seed Mix: _____

Type of Fertilizer Used: _____

Mixtures and Amounts: _____

Quantity of Seed Bags Used: _____

Size of Bag: _____ lbs.

Note: File all seed tickets behind inspection form.

Seeding Installation Method:

Mechanical Drill

Hydro Seeding

Other _____

Seed Placement Inspection

Inspection Compliance

| | | |
|---|-----|--------|
| 1. Verify seed mix is the correct mix design per specifications. Review approved seeding submittal. | Yes | No |
| 2. Soil is properly tilled prior to seeding. | Yes | No |
| 3. Seed uniformly placed on designated area. | Yes | No |
| 4. Final stabilization BMPs (mulch, blankets, cover crops, etc.) installed per specifications. | Yes | N/A No |
| 5. Irrigation plan implemented after seeding and fertilizer installation. | Yes | N/A No |
| 6. Land Owner willing to sign off on seeding inspection. | Yes | N/A No |
| 7. Photos taken of installation process. | Yes | No |
| 8. Were there any Non-Conformance Reports filed? | Yes | No |
| If yes, list NCR #____. Has it been resolved? | Yes | N/A No |

Inspection and Test Plan: Civil Inspections

C-5 Seeding Inspection

Photos

Note any deviations in the comments section.

Comments:

Installation Foreman: _____ Date: _____

Owner Representative *If Applicable*: _____ Date: _____

QA/QC: _____ Date: _____

Inspection and Test Plan: Civil Inspections

TBD Wind Energy Project

C-6 WTG Site and Road Restoration Inspection

0

Road Name or Identifier: _____ Road Length: _____ ft.

WTG Sites Included: _____

Subgrade Preparation

Inspection Compliance

| | | | |
|--|-----|-----|----|
| 1. WTG site and turning radius final grading completed per specifications. | Yes | | No |
| 2. WTG gravel ring(s) installed and compacted per specifications. | Yes | N/A | No |
| 3. WTG anchor bolt covers installed per specifications. | Yes | N/A | No |
| 4. WTG ID stickers installed per owner requirements. | Yes | N/A | No |
| 5. Crane pad(s) removed and area restored to original grade and compaction. | Yes | N/A | No |
| 6. Spoil material and large rocks removed from WTG site and road areas. | Yes | | No |
| 7. All truck turnaround areas removed and restored to original grade and compaction. | Yes | N/A | No |
| 8. Road shoulders de-compacted and restored to pre-construction conditions. | Yes | N/A | No |

Road Specifications

Gravel Design Width: _____ft. Gravel Design Thickness: _____in. Decompacted Shoulder Width: _____ft.

Side to side Max Grade: _____in. Maximum in 100' Crest: _____in. Maximum in 100' Sag: _____in.

| # | Station or GPS Location: | Actual Gravel Width: | Actual Gravel Thickness: | Gravel edge to gravel edge Elevation Difference (in.): | Actual Side-to-Side Slope: % |
|---|--------------------------|----------------------|--------------------------|--|------------------------------|
| 1 | | | | | |
| 2 | | | | | |
| 3 | | | | | |
| 4 | | | | | |
| 5 | | | | | |
| 6 | | | | | |
| 7 | | | | | |
| 8 | | | | | |

Road Checks shall be performed at a minimum every 1000'. If needed, use additional sheets.

| | | | |
|---|-------------------------------------|-----|----|
| | <u>Inspection Compliance</u> | | |
| 9. Fencing and gates installed per drawings and specifications. | Yes | N/A | No |
| 10. Road signage installed per owner/state/county requirements. | Yes | N/A | No |
| 11. Proper BMPs installed per SWPPP plan. | Yes | | No |
| 12. County or state approved removal of turning radius. | Yes | N/A | No |
| 13. Seeding and installation of final stabilization BMPs completed per drawings and specifications. Seeding inspection form has been filled out, completed, and filed (C-5). | Yes | N/A | No |
| 14. Culvert end sections installed per specification. C-2 Drainage Structure Inspection form revised, finalized, or new form filled out to exhibit change due to restoration. | Yes | N/A | No |
| 15. Were there any Non-Conformance Reports filed? | Yes | | No |
| If yes, list NCR #____. Has it been resolved? | Yes | N/A | No |

Inspection and Test Plan: Civil Inspections

C-6 WTG Site and Road Restoration Inspection

Photos

Note any deviations in the comments section.

Comments:

Civil Foreman: _____ Date: _____

QA/QC: _____ Date: _____

Inspection and Test Plan: Civil Inspections

TBD Wind Energy Project

0

C-7 Intersection Modification Inspection

Intersection Mod. I.D.: _____ State County Permit #: _____
 Drawing: _____ Effective Permit Date: _____

Location of Structure: _____

Type of Structure: Reverse Regular Other _____

Structure Height/Slope: _____ Structure Width: _____ Structure Length: _____

Sketch intersection modification in relation to nearby landmarks (streets, houses, power poles, etc.):

Inspection Compliance

| | | |
|--|-----|--------|
| 1. Permit has been reviewed by Civil Supt/Subcontractor. | Yes | No |
| 2. One call made. Ticket Number _____ | Yes | No |
| 3. Sloped so no ponding will accumulate (< 1%) per specifications. | Yes | No |
| 4. Sloped away from existing road. | Yes | No |
| 5. Maximum vertical crest or sag does not exceed ____in. in any 100' section. | Yes | No |
| 6. Approved culvert used/inspected. C-2 Drainage Structure Inspection form filled out and completed. | Yes | No |
| 7. Fill meets existing road grade: no humps or dips. | Yes | No |
| 8. Fabric installed per permit specifications. | Yes | N/A No |
| 9. SWPPP BMPs installed per drawings and specifications: silt fence, rip rap, etc. | Yes | No |
| 10. Intersection modification has been installed per permit. | Yes | N/A No |
| 11. Signage installed per traffic control plan. | Yes | No |
| 12. All work complies with state and local laws. | Yes | No |
| 13. All work complies with SWPPP permit. | Yes | No |
| 14. Were there any Non-Conformance Reports filed? | Yes | No |
| If yes, list NCR #____. Has it been resolved? | Yes | N/A No |

Note any deviations in the comments section.

Comments:

Civil Foreman: _____ Date: _____

QA/QC: _____ Date: _____

Inspection and Test Plan: Civil Inspections

TBD Wind Energy Project

C-8 Approach/Temporary Radius Inspection

0

Location of Structure: _____

Permit #: _____ Drawing: _____

Sketch Approach or Temporary Radius:

| | <u>Inspection Compliance</u> | | |
|--|------------------------------|-----|----|
| 1. Culvert inspections have been completed. C-2 Drainage Structure Inspection complete and filed. | Yes | N/A | No |
| 2. Approach/temporary radius constructed per permit/design. | Yes | | No |
| 3. Fill material used per permit/design specifications. | Yes | N/A | No |
| 4. Structure sloped to prevent ponding per permit and design specifications. | Yes | N/A | No |
| 5. Radius meets existing grade and/or permit requirements. | Yes | | No |
| 6. Sloped/shored per permit/design specifications. | Yes | | No |
| 7. Radius installed per delivery requirements. Review drawings, including TSA E.1, civil, and permit drawings. | Yes | N/A | No |
| 8. SWPPP installed per drawings and specifications: silt fence, rip rap, etc. | Yes | | No |
| 9. Drainage structure installed per drawings and specifications. | Yes | N/A | No |
| 10. Were there any Non-Conformance Reports filed? | Yes | | No |
| If yes, list NCR #____. Has it been resolved? | Yes | N/A | No |

Note any deviations in the comments section.

Comments:

Civil Foreman: _____ Date: _____

QA/QC: _____ Date: _____

Inspection and Test Plan: Civil Inspections

TBD Wind Energy Project

C-9 Intersection Modification Restoration Inspection

0

Intersection Mod. I.D.: _____ State County Permit #: _____
 Drawing: _____ Effective Permit Date: _____

Inspection Compliance

| | | |
|---|-----|--------|
| 1. One call made for utility locations. Ticket Number (if self performed): _____ | Yes | No |
| 2. Final grading completed per permit and design specifications. | Yes | No |
| 3. Ditch slope restored to existing slope prior to construction. | Yes | No |
| 4. Culvert end sections installed per specification. C-2 Drainage Structure Inspection revised, finalized, or filled out to exhibit change due to restoration activities. | Yes | N/A No |
| 5. Spoil material and large rocks removed from disturbed areas. | Yes | No |
| 6. Road shoulders de-compacted and restored to pre-construction conditions. | Yes | N/A No |
| 7. Fencing and gates installed per drawings and specifications. | Yes | N/A No |
| 8. Road signage installed per owner/state/county requirements. | Yes | N/A No |
| 9. Proper BMPs installed per SWPPP plan. | Yes | N/A No |
| 10. Intersection modification reviewed and approved by state/county.. | Yes | No |
| 11. Seeding and final stabilization BMP installation completed per drawings and specifications. | Yes | N/A No |
| 12. C-5 Seeding Inspection form has been filled out and completed. | Yes | No |
| 13. Were there any Non-Conformance Reports filed? If yes, list NCR # _____. Has it been resolved? | Yes | No |
| | Yes | N/A No |

(*Note any deviations in the comments section.*)

Comments:

Civil Foreman: _____ Date: _____

QA/QC: _____ Date: _____

Inspection and Test Plan: Civil Inspections

TBD Wind Energy Project

C-10 Misc. Sub Grade & Gravel Placement Inspection

0

Yard Name or Identifier & Sheet Number: _____

Acreeage of Yard: _____

Passes Inspection

| | | | |
|--|-----|-----|----|
| 1. One call made for utility locations. | Yes | | No |
| Ticket Number (If company/self performed): _____ | | | |
| 2. The yard is graded to promote positive drainage away from the yard to storm water outlets. | Yes | | No |
| 3. No visible humps or holes that would collect run off prior to gravel placement. | Yes | | No |
| 4. Final grading completed per permit and drawing specifications. | Yes | | No |
| 5. Subgrade passes Proof Roll Test. | Yes | | No |
| 6. Culvert sections installed per specification. C-2 Drainage Structure Inspection filled out. | Yes | N/A | No |
| 7. Spoil material and large rocks removed from disturbed areas. | Yes | | No |
| 8. Gravel depth checked and confirmed with subcontractor. | Yes | N/A | No |
| 9. Gravel placement length & width: Length: _____ x Width _____. | Yes | N/A | No |
| 10. Top soil piles located per drawings and specifications. | Yes | N/A | No |
| 11. Proper BMPs installed per SWPPP plan. | Yes | N/A | No |
| 12. Meets county set back and permitting requirements. | Yes | | No |
| 13. Seeding and stabilization BMP installation completed per drawings and specifications. | Yes | N/A | No |
| 14. C-5 Seeding Inspection form has been filled out and completed. | Yes | | No |
| 15. Were there any Non-Conformance Reports filed? | Yes | | No |
| If yes, list NCR #____. Has it been resolved? | Yes | N/A | No |

Note any deviations in the comments section.

Comments:

Civil Foreman: _____

Date: _____

QA/QC: _____

Date: _____

Quality Control Procedure

The Quality Control Procedure provides an example of the documented procedure accompanying the "Construction Period Road Inspection" subsection of the "Civil Construction Block". A similarly detailed procedure exists for each inspection in the full inspection and test plan.

C-1 Road Inspection

1.0. Purpose

To ensure that the road installation is completed per design drawings and specifications.

2.0. Revision History

3.0. Required Tools & Equipment

- Personal Protective Equipment (PPE)
- 25' and 100' tape measure
- Laser level
- Digital level
- Pick axe
- Two steel pins
- String line
- Hammer
- Measuring wheel
- Wood lathes
- Paint pen
- Digital camera
- Civil drawings and specifications

4.0. Procedure

- 4.1. Start by going through the inspection form line by line to know what you will need to look for once in the field. Also, fill in your job name, number, and the design specifications prior to printing the inspection form so you don't have to fill it out each time. Any changes to the C-1 Inspection form shall be approved.
- 4.2. Before going out on site to inspect roads, bring your road drawings and specifications. Also bring the required tools and equipment.
- 4.3. The first line on the inspection form will ask you for the road name or identifier. Each road section should have some sort of identification to determine the location of the inspection.

- 4.4. The next item will ask you if the topsoil has been removed. It may seem obvious if you're working with grass land; however, if you are working in a plowed field it may be hard to notice if they really removed the top soil or not. If the top soil has been removed and is accepted, you can circle "Yes" and move to the next line. You will need to review the specifications for the required depth of the sub-grade.



Figure 4.1: Removing Top Soil

- 4.5. The next line item will ask if the SWPPP Plan has been implemented and completed per specifications. Circle "Yes" if it is in place and move on with your inspection.
- 4.6. Before placing any base material, there are a few things that need to happen before cutting the contractor loose. First, the material that is planned on being used must be submitted to the civil engineers for their approval (ensure it has been accepted). Second, the subgrade must be complete and passing. This may require a proof roll of the sub-grade or even a density test, each requiring a third party inspector to complete the test. Once either has been completed and is accepted, you can circle "Yes". It is a good practice to note when the sub-grade actually passed on your sheet as well.

C-1 Road Inspection (continued)

4.7. Next on your inspection form you will find it asks you if geotextile fabric has been installed. Typically geotextile fabric is required; however, some soil types do not require it. You will need to check your specifications to determine whether this is needed or not. If it is required, ensure it has been installed properly and circle "Yes".



Figure 4.2: Installing Geotextile Fabric

4.8. The next line item will ask if the compaction reports have passed specification requirements. For the road base material to pass inspection, you will need to get the compaction reports from your third party tester on-site, and the results must meet or exceed the specifications. A good practice is to track where the road base has passed compaction requirements on a map so you're not missing any reports when it comes to submitting them to the owners.



Figure 4.4: Compacting Road Base



Figure 4.5: Performing QC Check on Gravel Installation

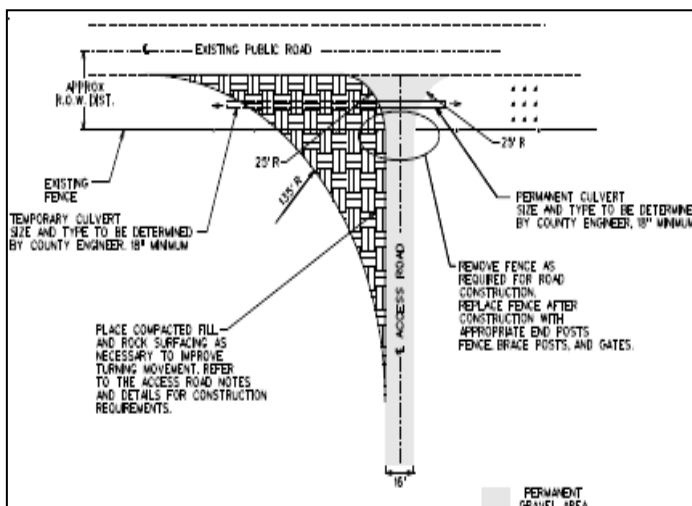

Figure 4.3: Typical Access Road Entrance Detail

4.9. The next line item will ask if the road radius for access points and curves has been installed per specifications. Usually the road radius is determined by the turbine manufacturer and transportation company. If inspection passes, circle "Yes" and move onto the next question.

4.10. The next step is to check your road width. Do so by placing two metal pins on each side of the road and measuring the distance between the two points. If there is a PE available to assist with the inspection, they can hold the other end of the tape instead of using the pins. This should be completed before the road shoulders have been pulled up. Once the shoulders have been pulled up, it will be hard to determine where the exact edge of the road is.

C-1 Road Inspection (continued)

4.11. Over the duration of the project, the thickness of the road will change from traffic and maintenance. So your QA/QC for the thickness of the roads should be complete when the final grading of the road has been done. However, you should spot check the depth of the roads during construction, as well, to avoid any major repair areas toward the end of the project. Try catching the problem areas while the crew is there placing the material, they are a lot more willing to do the work while they are in the area.

4.12. To complete the depth check, you will need your pick axe, tape measure, and wood lathe. Pick a hole in a random spot of the road (don't always do the center or edge of the road) until you reach the sub-grade. Once you have reached the sub-grade, measure from the top of the sub-grade to the top of the base material. This will give you the depth of the road. If this is within the tolerance of your design, it is acceptable. If not, you will need to get the contractor back and spot dump some material in the troublesome areas.

4.13. To measure crown height, take two bricks and a string line tied between the two. The distance between the bricks should be the width of the road. Use a tape measure to measure the distance from the string at the center and both edges. The distance at the edge minus the distance at the center should equal your crown height.

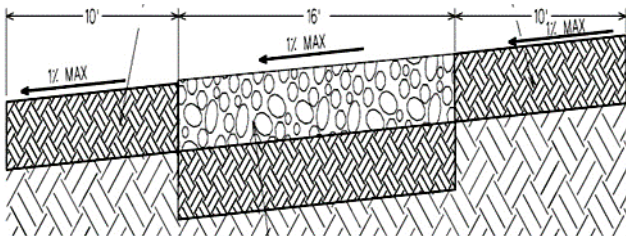

Figure 4.6: Typical Road Placement Cross Section

4.14. In some cases, the engineer may not require a crown to the road design. Instead they may design the road with a slope to maintain an existing drainage pattern (usually 1% to 2% max slope). You will need to adjust your inspection form accordingly.

4.15. Next you will need to check the actual grade of the road sections. The maximum grade should be per the engineer design and specifications. It is a good idea to double check with the crane manuals, as well, to make sure all ends are covered. If at all possible, check this before any base material is placed. If it is not within specifications, the

contractor will be able to work with the sub-grade a lot easier and cheaper than the base material. To complete the test, place your digital level on the road. The longer your level is, the more accurate your results will be. So if you have a small level, it is a good idea to place a piece of angle iron, or something that will stay true over the duration of the project, under your level. If your results come under your maximum allowable grade percentage, then the road is acceptable.

4.16. To check for dips and bumps, you can complete this task two ways. 1) Use a 100' tape measure and survey equipment or 2) take two bricks and a string line tied between the two. The distance between the bricks should be about 50'. Use a tape measure to measure the distance from the string to the road in high and low spots. If this distance is greater than the required dip or swale, it fails. Remember to subtract or add the height of the brick. It is important that you complete this inspection prior to any turbine component deliveries. If either of these are out of tolerance, the delivery trucks may get hung up and cause damage to their trucks.

4.17. In the comment section, record any notes that you feel add value to this inspection.

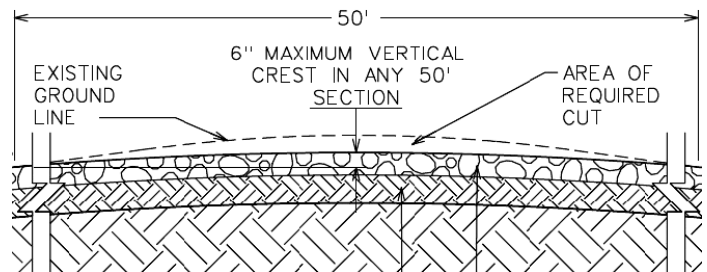

Figure 4.7: Typical Road Profile Crossing Existing Crest Area

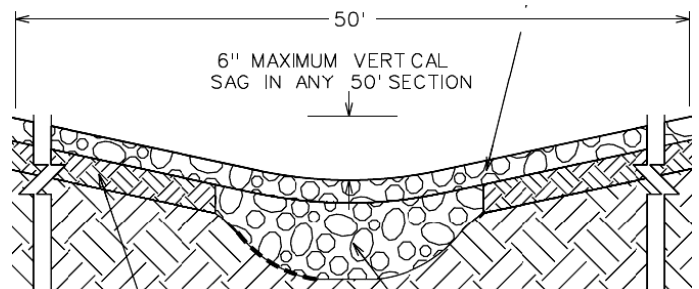

Figure 4.8: Typical Road Profile Crossing Existing Swale Area

C-1 Road Inspection (continued)

5.0 Approval

- 5.1.** Non-conformance notices (NCN) are written when there is an issue with some aspect of the road that cannot be fixed in a quick manner, e.g. that same day. If all NCNs have been closed, circle "Yes". If there is an open NCN issue, you will need to verify that it is closed.
- 5.2.** A photographic record is not required for each road section inspection. However, photos should be taken of the installation process and final product for documentation purposes.
- 5.3.** Depending on the dynamics of your project, there may be a few road modifications during construction. This may be due to landowner issues, wet land issues, or other. Ensure all road changes have been approved by the civil superintendent and all applicable parties (owner, landowner and civil engineer). The civil drawings shall be updated and redlined with all road changes.
- 5.4.** If all the items on this inspection form have been recorded and accepted, and all items are within the specified tolerances of the design drawings, the road is acceptable. Have the installation foreman, as well as yourself, sign the bottom of the form. The road inspection form will then be filed in its appropriate quality control book.

6.0. Records

- 6.1.** C-1 Road Inspection Form
- 6.2.** Photographic records of the road installation
- 6.3.** Third Party Subgrade Compaction Test Results
- 6.4.** Third Party Base Compaction Test Results
- 6.5.** Update Civil Drawings with all road changes, if applicable

RP 902 Lean in an Operational Environment

The following recommended practice (RP) is subject to the disclaimer at the front of this manual. It is important that users read the disclaimer before considering adoption of any portion of this recommended practice.

This recommended practice was prepared by the AWEA Quality Committee. The committee would like to thank:

Primary Author: Scott Mathieu, EDP Renewables North America LLC

Contributing Authors:

Thomas Brazina, EDP Renewables North America LLC

Ryan Griffin, Mortenson Construction

Brandon Judish, NextEra Energy Resources

Gregory Lilly, E.ON Climate & Renewables North America

Fritz Oettinger, Vestas

Karen Tucker, Wanzek Construction, Inc.

The committee first authored this recommended practice as a separate whitepaper that was published on February 28, 2017.

Purpose and Scope

The scope of “Lean In an Operational Environment” addresses applying lean concepts in wind site management operations.

Lean in an Operational Environment

1. Lean Overview

1.1. What is Lean?

Lean is a set of tools and practices aimed at reducing waste and improving reliability. Waste is defined as any activity that consumes resources but does not add value to a particular process. It also includes any product that the customers are unwilling to pay for. By eliminating waste and non-value added time and activities, one can shorten the timeline from when the customer orders the product or service to when the customer receives the full value of the product or service. As the provider of the product or service, one can reduce labor, materials, and cycle time with the ultimate goal of improving customer satisfaction and business performance in multiple areas, such as safety, quality, cost, and on-time delivery.

1.1. What is Lean?

(continued)

Perhaps the best way to understand the concept of lean thinking is to consider an example from everyday life. Everyone is familiar with the daily process of brushing their teeth. The steps of the process include applying water and toothpaste to a toothbrush, rubbing the brush vigorously over our teeth, spitting out the wastewater, rinsing the toothbrush, etc. The steps that directly contribute to the desired process output of clean teeth and fresh breath are those that provide value to the customer, in this case yourself. The resources expended when rubbing the brush over your teeth are surely value adds. But what about the time spent searching for the toothpaste tube in the drawer? This provides no direct value to the customer, but consumes time and energy. Perhaps you discover that you are out of toothpaste and must walk down to a basement closet where you store the inventory of unopened toothpaste tubes. This is also wasted time and motion in the brushing process.

Lean teaches us to first be aware of and identify the most common eight types of waste present in our processes. Lean also gives us tools to reduce or eliminate those wastes, thereby increasing the efficiency of our process. Lean is:

- A working attitude with a bias for action
- Focusing on adding value and eliminating waste
- Continuous improvement

1.2. History of Lean

For centuries, manufacturing was a craftsman's job. Most fabricated items such as furniture, musical instruments, and weaponry were hand-made. This caused products to be very expensive, not replicable (each piece is unique), extremely variable in terms of quality, and highly dependent on the craftsmen that produced the product. As a result, affordability and mass production were unobtainable until the industrial revolution of the 1900s.

1.2. History of Lean

(continued)

During the early 1900s, the automotive industry was the most innovative of the era. Automobiles were manufactured all over the world; however, only Henry Ford had the innovation to develop mass production techniques. Ford Motor Company™ was the first company to implement the assembly line concept for building his classic Model T. He used various methods that divided labor and used hundreds of unskilled employees to perform one or two repeatable tasks, such as tightening two specific screws on the assembly line. Henry Ford was able to mass-produce his Model T Ford with high production rates at an affordable cost. This approach, though cost effective, was laden with issues of its own: quality and flexibility being the biggest challenge to overcome. The famous quote by Henry Ford is, “You can have any color, as long as it’s black”.

In 1936, Toyota Group™ was established. Toyota, fascinated with Ford's mass production assembly line, appointed an engineer to study the Henry Ford mass production operations. Japan at this time (1945) was heavily involved in World War II. Many of Japan's best and most intelligent men and women were at war.

Japan was weaker than ever and had limited resources at their disposal. Money for machinery, skilled labor, labor laws, and small market sizes were variables Toyota needed to overcome. Toyota knew they had to develop a company that was extremely flexible, utilize all of their limited machinery (no downtime), only manufacture exactly what the customer ordered, eliminate excess inventory, and empower every employee to own quality of all upstream workmanship. Toyota could not afford defects or quality of workmanship issues. Thus, the Toyota Production System (TPS) and lean were born.

In 1950, the TPS model was proven to be very successful. Using the Henry Ford mass production system as a benchmark, Toyota was able to assemble a car in 16 hours, an improvement over the 31 hours of Henry Ford. Toyota's biggest achievement was in quality and inventory. Toyota's employee empowerment approach reduced defects by 65% in comparison to Ford and minimized inventory from Ford's 2 weeks to only 2 hours. Over the next 38 years, Toyota's market shares rose from around 4% in 1950 to over 35% in 1988, surpassing Ford.

1.2. History of Lean

(continued)

From 1980-2000, universities and companies researched and developed many variations of the TPS to meet their own educational or business needs. This era is known as the “Lean Institute” phase and focused on implementing the TPS philosophies, tools, and methods in manufacturing industries. Companies quickly realized that these lean principles did not only apply to manufacturing, and from the year 2000 to today the “Lean Enterprise” era was established.

Today, industries such as banking, telecommunications, manufacturing, and energy implement lean tools and philosophies to foster continuous improvement and innovation, becoming industry leaders within their business sector.

1.3. Misconceptions about Lean Implementation

One of the most common misconceptions and misapplications of lean is thinking that lean means simply getting rid of process steps, process time, or process labor. Lean should never eliminate needed steps in a process. Remember that lean reduces waste and adds value. Setting arbitrary goals to reduce process cycle time or process costs by a certain rate, without understanding the value dynamics of your process, can lead to the elimination of truly value added steps. Instead, we need to first comprehensively define what is waste and what is value so that we can focus on reducing the waste in the process rather than the core of what we do well, i.e. the product and process value itself.

Lean may also be inappropriately described as a tool for manufacturing processes only. While it is true that lean has its roots in manufacturing, the principles of lean apply to all processes and all industries. Lean concepts and tools can be applied to all stages of wind generation, from construction to operations, from reducing crew travel and transportation of equipment during the construction of wind turbine to ensuring that time spent searching for tools during turbine maintenance is reduced by standardization and kitting of techniques. In addition, reducing motion also eliminates the opportunity for injuries. Implementation of a strong safety culture will also promote a positive lean culture.

1.4. Theory of Lean and Six Sigma

In any process that is consistently done over time, we can utilize Six Sigma to understand the amount of process variation a particular process is experiencing. The amount of process variation from a specific target is known as process variability. Identifying this variability identifies sigma values (how close are we to the target). Six Sigma is the most ideal process capability metric. Achieving a Six Sigma level process means the process achieves the desired target 99.99999% of the time. On the other hand, lean focuses on the individual steps within the process and ensures machine reliability and efficiency over time. Thus, the two complement one another and together are “Lean Six Sigma”.

In any process, we will find examples of the eight types of waste:

- **Transport:** movement of people, product, and information
- **Inventory:** storage of spare parts, work in progress, finished goods, or supplies
- **Motion:** reaching, lifting, bending, or other movements
- **Waiting:** for approvals, parts, equipment, or people
- **Over Production:** producing more than is needed or before it is needed
- **Over Processing:** doing more work than is necessary, producing tighter tolerances or grade than is necessary
- **Defects:** rework, scrap, all inspection activities
- **Talent:** under-utilizing people, the wrong person in the wrong job, lack of training or tools

An important concept in lean thinking is that of Kaizen. Kaizen is a practice of continuous improvement made by small, frequent changes for the better. Traditional process improvement thinking often focuses on large step-wise improvements and trying to achieve the “perfect” process before implementing a change. Kaizen looks for small changes that can be made every day, by everyone in the process, to ultimately drive a much larger cumulative improvement outcome.

Kaizen practices can be formalized within an organization or process with simple practices such as a daily improvement board or stand up improvement meeting. At the beginning of each shift, team members can gather for several minutes at the improvement board and each team member writes down one way they will improve their work during the coming day or one way in which they improved the process in their last workday.

2. Typical Lean Concepts

Before we venture into specific lean concepts, it must be communicated that these tools are used to solve specific business problems. For example, you would never use a hammer to unscrew a nut, and lean tools are no different. You would not use value stream mapping to determine the root cause of a particular failure in a gearbox. These tools are simple to use when you know where and when to apply them.

2.1. Value Stream Mapping: Identifying Process Gaps

Value stream mapping is a lean method used to analyze the current state of function in a value chain and design an optimized future state. A value chain is any process or series of physical events that delivers a product or service to a customer. Value stream mapping seeks to identify each task that discretely adds value to the overall process, displaying the measured time, labor, information, and material inputs and outputs of each task. The value stream map is based on the concept of one-piece-flow, or following a single 'component' through a series of value added steps. Knowing and documenting the current state of a process is the first step in working toward an ideal future state. Understanding the concept of 'flow' is also important to the value stream concept, as it seeks to optimize the efficiency of the overall process not the individual efficiencies of every resource involved. This allows the user to visualize where delays and waste may occur in the broader process, even when each sub-task may appear to be optimized.

To create a value stream map, representatives from each functional area in the process should participate. The engagement of the team is key both to ensuring the greatest accuracy and to facilitating conversations that may not occur in the day to day working environment. Not all participants will be able to envision an optimized future state. However, they may be able to identify smaller opportunities to improve flow. It's desirable for the team to walk and observe first hand the physical process taking place, including measurement of inventory, cycle time, changeover time (duration between locations or events), resources required (number of operators and equipment), utilization of resources, rework or quality metrics, and available working time. Once the current state is measured and an optimized future state is envisioned, the gap between current and future state should be analyzed and an action plan developed to close the gap. Value stream mapping has been known to identify up to 99% of the non-value adding activities embedded in the current state. If done right, this lean method will result in tangible improvement steps that can be prioritized based on return on investment.

2.2. “5 Whys”: Fault Analysis or Root Cause Analysis

"5 Why" analysis is a foundational root cause analysis method designed to be applied more quickly and at a higher frequency than other, more formal root cause analysis tools. The primary goal of the "5 Why" analysis is to get to root cause by repeating the question "Why?" five times. With each consecutive iteration, the troubleshooter is brought closer to root cause. In some cases, multiple root causes can be identified, and each one may have its own series of "Why?". Generally, the fifth "Why?" will point to a process breakdown versus a physical problem. For example, a motor failure due to lack of bearing lubrication may ultimately uncover a faulty preventive maintenance program. "5 Why" analysis is a very good introductory method to other, more sophisticated forms of problem-solving.

2.3. Fishbone Diagrams: Turbine Fault Analysis or Root Cause Analysis

Similar to "5 Why" analysis, fishbone diagrams seek to define and illustrate underlying causes of a defect or source of variation. Fishbone seeks to classify sources of variation into categories such as people, methods, machines, materials, measurements, and environment. This method can be useful when a team is stuck or needs to go beyond the simpler "5 Why" approach and becomes a very good way to visualize multiple variables or root causes to a problem.

2.4. Single Minute Exchange of Die (SMED): Main Component Exchanges and Construction

Single Minute Exchange of Die (SMED) is a system for dramatically reducing the time it takes to complete changeovers. Shigeo Shingo, a Japanese industrial engineer who had a record of accomplishment of helping companies reduce changeover time by a documented 94%, successfully implemented a SMED program that had benefits of reducing costs, increasing safety and quality, improving responsiveness to customer demand, reducing inventory levels, and allowing for improved startups.

While it may not be possible to reduce all changeovers to one minute, this process takes the approach that any downtime or non-value added time is eliminated. Like most lean tools, SMED is in other industries outside of just manufacturing. NASCAR™ pit crews, for example, employ SMED to further study and reduce the times of their pit stops. Because SMED is a relatively resource intensive process, sound judgement is necessary in order to determine where it can be best applied.

2.4. Single Minute Exchange of Die (SMED): Main Component Exchanges and Construction (continued)

It may be the case, for example, that there are other areas that should be addressed first before changeovers. If mechanical reliability is a greater loss point than changeovers, it may make more sense to focus on implementing a reliability centered maintenance program before reducing changeovers. In this scenario, changeovers may have additional variability due to mechanical issues that arise and need to be corrected in that downtime.

2.5. Overall Equipment Effectiveness (OEE): Hourly or Energy Based Availability

Overall equipment effectiveness (OEE) is a standard for measuring manufacturing productivity. The concept was developed in the 1960s to evaluate how effectively a manufacturing operation is utilized. Because results are expressed as a percentage of standard, OEE can be compared between different operations or industries. To achieve a score of 100% OEE, a system must run at 100% quality: zero defects, 100% performance, and as fast as system design speed allows. It must also run at 100% availability: no stop time. By measuring OEE and the underlying losses, productivity can be systematically improved. Variances from standard can be graphed in a Pareto diagram, and improvement plans can be made to address the highest impact losses from system performance. Because OEE takes into account all losses, it can be considered a holistic measure of performance.

2.6. 5S (Sort, Set, Shine, Standardize, Sustain): Inventory and Tool Management

5S is a process to reduce waste, improve safety, and optimize productivity through maintaining an orderly workplace and using visual cues to achieve more consistent operational results. 5S addresses many of the eight wastes of production, and many organizations use 5S to set a foundation for developing a continuous improvement culture. 5S is equally applicable and effective in all sectors.

The process was developed in manufacturing and was popularized by Toyota. The term 5S references the first letter of the Japanese words for each step in the process. English translations are not exact but typically maintain the nomenclature. 5S requires the user of a workspace to be directly involved in the organization and sustainability of the process. Consistent utilization of this method can lead to a greatly increased sense of ownership for equipment, with gains in safety, quality, morale, and productivity.

3. Applying Lean Concepts in Wind Site Management Operations

3.1. Organizational Alignment and Commitment to Continuous Improvement

As companies implement continuous improvement to streamline processes and reduce costs, too often lean tools are deployed as the objectives rather than as specific project goals. Unfortunately, training for these tools is typically done in a shotgun approach, delivering an unintentional message that short-term results are the desired endgame. These project initiatives may result in respectable cost savings, but on their own will never release the full potential of people in an organization unless reviewed and aligned with corporate goals. So before anyone trains and assigns champions to implement 5S principles, standardize a service, or optimize warehouse inventory, a more fundamental focus on team culture and organizational alignment needs to be framed at all levels.

Since “you cannot improve what you can’t measure,” a lean program will typically start with an event defining the organizations key metrics, including how they will drive department, team, and finally individual day-to-day measures. Every company has a mission statement or a set of goals based on visions and values that coalesce into a written declaration of its core purpose of existence. The first stage in developing a continuous improvement culture is for everyone to understand the organizational measures and how they will affect the strategic goals.

Most organizational measures can be organized into one of Kaplan and Norton's four categories of a balanced scorecard: customer, financial, process, and learning and growth^[1]. In addition, manufacturing and heavy industry typically use safety as a fifth category. With long-term and annual strategic goals for reference, each department and team should brainstorm key measures that align their daily activities with the corporate goals.

When developing these measures, no more than one or two per category are necessary. Using a benchmark, like the 31 seconds visual management rule, basic dashboard metrics would provide anyone a three second process overview, a 10 second display of trends, and in 20 seconds identify the solutions and proposed improvements currently being pursued. Then, by creating tiered metrics, an organization can use dashboards to drive daily team huddles (stand up or green area meetings), further aligning management and supporting departments with field operations in vision and direction. This not only helps provide clear instructions and goals for individual accountability, but also enables better information sharing and planning to address critical issues as they develop. These are all important first steps in developing and maintaining a continuous improvement culture.

3.2. Cultural Onsite Enablers

A company culture is generally defined as the collective way in which employees interact to make the day-to-day, large and small, decisions that execute the organization's vision and strategy. Even with all of their strengths, lean tools arguably only contribute 20% to a successful continuous improvement program. However, if an organization has a strong lean culture, it will contribute the other 80%. Hence, once the foundational strategy is clear to everyone and measurement goals are established, additional cultural enablers can be developed into a framework that promotes a philosophy of seeking perfection in all work processes.

Clear goals and metrics, along with daily communication, are clearly important in a lean culture as described. Still, much of a cultural foundation lies in linking common HR behavior expectations to lean implementation rules and standards. The processes of recruitment, formal orientation, training, individual development, and reward systems all play a large part in giving employees the basic skills and instincts to contribute to company improvements. And once these links have been shaped, the focus must be redirected to leadership, which needs to gain the respect of new employees through both coaching and mentoring performance objectives.

Organizational alignment and culture building are not complicated, but the processes are broad in scope. Development of a lean culture needs to cascade through an organization and be introduced from the moment a potential candidate is interviewed, through orientation and on-the-job training, and continue well into a person's career with the company. This enables leadership to demonstrate humility by constantly engaging employees and providing them with personal learning and development opportunities for growth.

3.3. Common Mistakes and Lessons Learned

There is plenty of opportunity to learn from poorly implemented lean programs. The internet is littered with case studies and war stories of improvement projects gone wrong. For wind energy, the top ten common mistakes can be summed-up as follows:

3.3. Common Mistakes and Lessons Learned

(continued)

3.3.1. Starting a lean transformation without experienced and professional help

It is very difficult to complete a lean event if there is lack of training or involvement in continuous improvement work. Whether the team draws on an internal lean facilitator or contracts an external expert, it is always best to employ someone with Kaizen experience to work with teams during the start of any project or major program.

3.3.2. Relying completely on a lean champion

On the other hand, a strong and committed implementation team is necessary for any project to be successful. External experts typically do not have the authority or commitment to make things happen that are necessary to fully optimize a process.

3.3.3. Too many conflicting metrics

The KISS (Keep It Simple Stupid) principle needs to be closely followed in regards to dashboards. One measurement per category is ideal, but never have more than two. While there may be dozens of key performance indicators (KPI) being tracked by various teams or departments for each category, only the primary metrics should be displayed for daily huddle meetings.

3.3.4. Continuous improvement not linked to a business plan

This mistake is easily rectified through communication. Before any actions are initiated, each group or individual needs to submit a brief plan or project charter. The proposal must be quickly reviewed, compared to the annual plan and/or other projects in queue, and approved by a designated leader or cross functional team. This is to avoid one of the worst “wastes”: doing work that does not need to be done at all.

3.3.5. Not providing adequate training, facilitation, and follow-up

A few hours or days of training will not create an expert. Continuous improvement teams need to be developed using a combination of classroom training, project work, and benchmarking. And even when a skilled group is available, a facilitator needs to be identified or trained to direct and focus team progress.

3.3.6. Believing a tool, such as 5S implementation, can be completed in a day or even week

One can seldom complete the "Set in Order" step of a 5S project in a week. Two or three rounds of review are normally required to be sure excess material, tools and equipment are properly positioned. A process checklist with defined steps is the best way to ensure sustainability and accountability.

3.3.7. Treating symptoms and not determining root cause

Unfortunately, some problems get fixed only to reoccur. Lean tools such as the "5 Why" analysis are specifically designed to guide a team to define the root cause. While these methods take more time and discipline, solving a reoccurring problem normally saves a lot of time and cost.

3.3.8. Believing you will achieve a lean transformation only by applying lean tools

While all of the lean tools can help solve problems and reduce costs, creating a lean culture is the endgame.

3.3.9. Lack of top management understanding and commitment

No program will ever survive leadership apathy. Lean needs to be understood and promoted by top management. Employees are inspired to improve by leadership "walking the talk" and expecting to see management embracing change and pursuing perfection.

3.3.10. Making the statement and believing "we have completed a lean program"

It is called "continuous improvement" because the journey is never complete. When you stop improving, there is always another entity willing to further innovate and claim your business market share.

4. Lean and Site Management Principles

Many people ask about the difference between quality ISO standards and lean implementation. The best way to communicate the difference is to recognize that there is not a difference. Quality by itself is an overarching umbrella that uses various methods to improve standards and improve operations. Lean is the agent that bonds us to our ISO requirements and maximizes the value of our product to our customers. Top organizations may be ISO compliant, with rigorous quality manuals and procedures, but lack innovation, culture, and continuous improvement.

Lean innovation takes a good quality program to the next level of operational excellence. In order to achieve this level of operational excellence, a company must have the basic quality programs in place. The quality program will provide an essential foundation and further establish a corporate culture of structure and continuous improvement. Companies that view the certification as the end objective (check the box) will not be as successful as companies that implement a lean program to accompany their quality program. A lean program will further enhance a company's quality program and improve the day-to-day operations. Reducing safety incidents, improving product reliability, and improving customer satisfaction takes continuous improvement. The lean tools will only help facilitate these improvements.

4.1. Metric Development and KPI Management

4.1.1. Key performance indicators (KPI) are set by management.

- Goals and objectives are identified through management and customer expectations.
- Quality expectations, or customer requirements, are translated by management.

4.1.2. Metrics are reflective of control point data.

Metrics are the data points that reflect process or product performance. These metric points are identified by the quality plan to support the KPIs.

4.2. Accountability and Ownership

4.2.1 Quality Plans: Proactive versus Reactive

Quality planning should be performed in conjunction with other planning processes. To plan for quality, the team identifies the quality requirements and standards for the deliverables and documents how the project will demonstrate compliance.

The items to review to assist in the identification of quality requirements include, but are not limited to, the following:

- Project charter or scope statement describing the deliverables and acceptance criteria
- Work breakdown structure (WBS) identifying each deliverable
- Cost or budget outlining constraints to providing the deliverables
- Schedule highlighting the timeframe to deliver the project
- Risk register identifying information and threats to successful project completion
- Outside factors, including regulations or operating conditions, impacting the project
- Organizational process assets, including quality policies, supplier management programs, and lessons learned, assisting the project

As part of identifying the quality requirements, the team is to be aware of the benefits of meeting quality requirements, including less rework, higher productivity, lower costs, and increased stakeholder satisfaction. The tradeoff to delivering a quality project is the “cost of quality”, including the costs incurred in preventing non-conformance to requirements, inspecting the deliverables for conformance, and reworking a deliverable to meet requirements.

4.2.2. Quality Assurance (QA) and Quality Control (QC)

QA can be defined as a set of activities designed to ensure that processes are established ensuring the project deliverables comply with relevant quality standards throughout the project lifecycle, including project audits and process checklists. QA is also the process of auditing or assessing the quality requirements and processes during the production of the deliverables to ensure the appropriate quality standards and operational definitions are used.

4.2.2. Quality Assurance (QA) and Quality Control (QC) (continued)

Typically, QA activities are performed during project planning and execution. QA is closely related to QC in that QA processes utilize measurements obtained during QC to adjust or improve processes, ensuring non-conformances are prevented. QA activities may be conducted during the specific project being worked or may be part of an overall company or business unit initiative for continuous improvement.

QA activities can involve, but are not limited to, the following:

- Reviewing performance measures (How is the project performing compared to plan?). Ongoing issues may indicate non-conformance.
- Examining project deliverable status (Are the deliverables acceptable?). Rushed deliverables increase non-conformance.
- Determining schedule progress (What is the schedule status versus plan?). Nonconforming deliverables may be causing rework.
- Evaluating project costs incurred (What is the current actual project cost versus plan?). Nonconforming deliverables incur cost to correct.

Typically, QA activities are performed as part of a self-assessment or audit process and should complement a lessons learned process that includes identifying best practices, opportunity areas, performance gaps, sharing information, and proactively offering assistance in a positive manner to improve.

The results of QA activities can include change requests to either rework specific deliverables or to modify deliverables to meet the quality requirements. Additionally, corrective and preventative actions can be identified to address current issues and to prevent recurrence.

QC can be defined as a set of activities designed to evaluate the deliverable to ensure compliance with relevant quality standards throughout the project lifecycle, including inspection and testing. QC is product or service oriented.

4.2.2. Quality Assurance (QA) and Quality Control (QC)

(continued)

Performing QC is the process of inspecting and measuring the deliverable against the quality requirements. QC activities are performed throughout the project and involve the measurement of 'planned' versus 'actual' results.

The planned results, or acceptance criteria, are defined during the planning phase of a project. As the deliverables are produced, they are measured with actual results. As long as the actual results are within the tolerance range, or acceptable variance, then the deliverable is in conformance. If the actual results are outside the tolerance limits planned, then the deliverable is in non-conformance and follows a disposition process. The disposition process determines if the deliverable requires reworking, scrapping, or accepting through a change request process.

QC activities can involve, but are not limited to, the following:

- Inspection of project design, both internally and externally created
- Details drawing completeness and accuracy
- Designing input/output (I/O) points
- Bill of material (BOM) completeness and accuracy
- Vendor surveillance or inspection program
- Establishing inspection hold points for critical material
- Ensuring vendor is producing material within design limits
- Inspection of received materials against the design or order upon receipt
- Identifying that the correct part numbers, quantities, and items are delivered
- Implementing a disposition process for non-conforming materials

4.2.2.1. Inspection and Test Plans (ITP) for Identified Activities

ITPs are activity roadmaps with the procedures, skills, and tools needed to perform the sequential tasks, with control points for the inspections and data identification.

4.2.2.2. Skill Sets and Qualifications

Identify in the quality plan the necessary skill sets and qualifications to perform the identified tasks.

4.2.2.1. Resources

Identify in the quality plan the necessary resources to execute the plan. Resources may include workforce, equipment, documentation, software, hardware, and logistical needs.

4.3. Sustaining Results and Continuous Improvement

4.3.1. Monitor, Control, and Improve

Monitor and control involves review of the QA and QC activities to ensure the deliverables are produced meeting the quality requirements. Controlling project quality helps ensure non-conformances are identified prior to project close. The benefits of meeting the project quality requirements are to be reviewed against the cost of quality from following the value added processes to meet or attempt to meet the quality requirements.

Tools and techniques utilized to monitor the project quality include, but are not limited to:

- Identification of deliverable non-conformance
- Control points
- Variance analysis
- ITPs with control points
- Project self-assessments
- Project audits
- Change management processes and associated change logs
- Performance reports
- Internal audits or daily walk downs

Review deliverable quality requirements on a defined periodic basis to ensure they are being met or the correct preventative actions are established. Additionally, use data reviews to use leading indicators, as well as lagging indicators, to determine action.

4.3.2. Supplier or Contractor Quality Plan Assessments (Oversight and Assurances)

All quality plan requirements are cascaded throughout the supply base and are ensured through documentation and verification.

4.3.3. Documentation and Record Management (Data Package Requirements)

All associated documentation and records are formalized and maintained throughout the project. All assurances are made to verify correct procedure usage, record integrity, and maintenance.

4.3.4. CAPA System (Corrective Action/Preventive Action)

An effective CAPA system is in place to both prevent issues from occurring and to identify issues and concerns that have occurred to ensure corrective action and to prevent recurrence.

4.3.5. Communicate

The process of communicating and consulting with key stakeholders on quality management status is facilitated through the use of project self-assessment, audit reports, inspection reports, and cost or schedule updates. This communication may also be part of a non-conformance or corrective action program. The team is to document and communicate the non-conformance, along with the associated corrective action, preventative action, and possible lessons learned. At a minimum, deviations from quality standards are required to be recorded on the project report monthly.

5. Warehouse and Tool Management

5.1. Warehouse Optimization

In the 1980s, the Toyota Production System was introduced in North American manufacturing as “Just-In-Time” (JIT) inventory control. Basically, the concept was that inventory is an insurance policy. As equipment, processes, and operator skill levels improved throughout an operation, the raw materials, component parts, works-in-process, and finished goods inventory throughout the manufacturing process dramatically decreased. In the automotive industry, this meant millions of dollars of capital were freed up with a successful JIT program. Optimizing space utilization, material flow, order picking, and dock operations create significant cost savings in material and labor.

At the site level in the wind industry, most warehouse facilities are very small in comparison to the manufacturing industry. An efficient use of space is always desired in construction and service operations to control cost. Whether the building is new or an existing property, the first step in improving material and work flow is to use the value stream mapping tool. Wind farm warehouse layouts are fairly standard in design, consisting of pallet racking, small parts shelving, oil storage, oil containment, and shipping/receiving areas. With limited floor space, the goal is often simply to use all horizontal and vertical space as effectively as possible, reducing time to pick and stage parts that could otherwise be spent more productively. For example, oil management can be optimized by setting up a rack with the different oils, coolants, and cleaners in bulk storage tanks. The tanks can be easily filled by pumps and dispensed by hoses connected to a valve header.

5.2. Metrics and Accountability

The standard measures for monitoring the health of a warehouse are inventory accuracy and total cost. Measurement of inventory turns can also be applied. However, many stock decisions are based on component lead-times, and inventory turns often are dictated by the make, model, and age of the equipment. Inventory levels can balloon or become inaccurate very quickly if not kept in check. Non-inventory items, especially, tend to grow exponentially if not tracked by piece or part count. Most non-inventory items are written off and have no assigned cost, which makes information difficult to share with other sites. A good practice is to establish a “blacklist” of non-inventory parts that can be shared, especially after initial construction, otherwise the items end up lost or damaged in the yard or warehouse without a chance of recovering value, except, inevitably, as scrap.

5.2. Metrics and Accountability

(continued)

Every warehouse needs a trained associate to maintain the stock and to maintain the integrity of the material requirements planning (MRP) system that tracks inventory levels and re-order points. While great effort is typically paid to training technicians, formal inventory control training is usually non-existent, consisting of basic MRP software data entry with no warehouse or logistic training. With wind farm sizes varying dramatically, it is often not viable to have a dedicated inventory coordinator onsite. In either case, an employee with the aptitude and organizational skill needs to be identified and made accountable. Bar coding can be used to enter and relieve stock, for example. And with many scanning systems, the parts can be scanned and assigned directly to a work order. Ultimately, there needs to be one local associate assigned to guarantee the integrity of the part levels through daily or weekly cycle counting. A great resource to help setup inventory and logistic training is the American Production and Inventory Control Society, or APICS™. Their website offers learning resources and an industry certification to use as a benchmark.

6. Technician Continuous Improvement

In order to create a quality culture, it is important to ensure that technicians receive skills and knowledge regarding the use of data driven problem-solving. This could be analysis for special cause variation or the use of Six Sigma tools for common cause variation. In an ideal state, promotions to more advanced wind technician levels include the requirement to have the data driven problem-solving skill set in place. This includes both the academic and real world application of quality tools.

A format used for special cause variation analysis is the “Quality Improvement Story”. This is a seven step problem-solving process in which the team uses data to identify a project indicator and sets a target for improvement. A tie to the customer focus and company strategy is established, ensuring focus remains on the primary key objectives as defined by the customer. Project teams gather additional information, using tools like Pareto graphs, to further scope the problem. Then, they use an additional tool for analysis, such as the fishbone diagram, to brainstorm potential causes. The potential causes are verified through testing. The testing performed must identify the true root cause of the problem and any contributing factors.

6. Technician Continuous Improvement (continued)

Countermeasures used to reduce or eliminate the root cause are identified through the use of a countermeasure matrix, which helps the user identify potential corrective actions, costs, and risks of implementation. Results are proven through plotting the post-countermeasure project indicator data and comparing against the initial target. The team then works to ensure that countermeasures are replicated across the site and across the applicable turbine technology in the standardization step. Remaining actions and the next project are identified in the future plans step.

Common cause variation is addressed through Six Sigma's "Define Measure Analyze Improve and Control" (DMAIC) methodology and is recommended for the wind operations management ranks. The technicians may be called in to participate in a measurement systems analysis or process mapping exercise.

6.1. Continuous Improvement Process for Technicians (Quality Belt Training)

All technicians are required to take quality training to reinforce the following concepts:

- Project charter
- "Supplier - Input - Process - Output - Customers" (SIPOC)
- Voice of customer
- Process map
- Data collection plan
- Indicators and metrics
- Graphs (line graphs, bar charts, and Pareto graphs)
- Brainstorming
- Affinity diagrams
- Cause and effect (fishbone diagrams)
- "5-Why" analysis
- "Non-Value Add / Value Add / Business Value Add" (NVA / VA / BVA) analysis
- Root cause verification
- Future state process map
- 5S (Sort, Set, Shine, Standardize, and Sustain) or 6S (Safety)
- Countermeasures matrix
- Pilot countermeasures
- Process control plans
- Visual process management
- Kanban (a visual signal used to trigger an action)
- "Poka Yoke" (mistake proofing)
- Standard work

6.2. Organizational Cultural Reinforcement

The company should provide opportunities for the technicians to compete at both the regional and corporate level with their completed quality projects. The quality projects must demonstrate measurable savings to the company and enable replication of countermeasures across the wind turbine technology. The competitions will help to share learnings from other projects and allow the technicians to develop relationships with other team members across the organization. The competitions should be held at an annual frequency and help to improve employee engagement in the area of quality.

6.3. Technician Ownership and Accountability

Technician accountability is established through the following two processes (note that participation in quality projects is expected for each rank):

6.3. Technician Ownership and Accountability (continued)

Quality Requirements for Promotion Process

Quality Certification Process

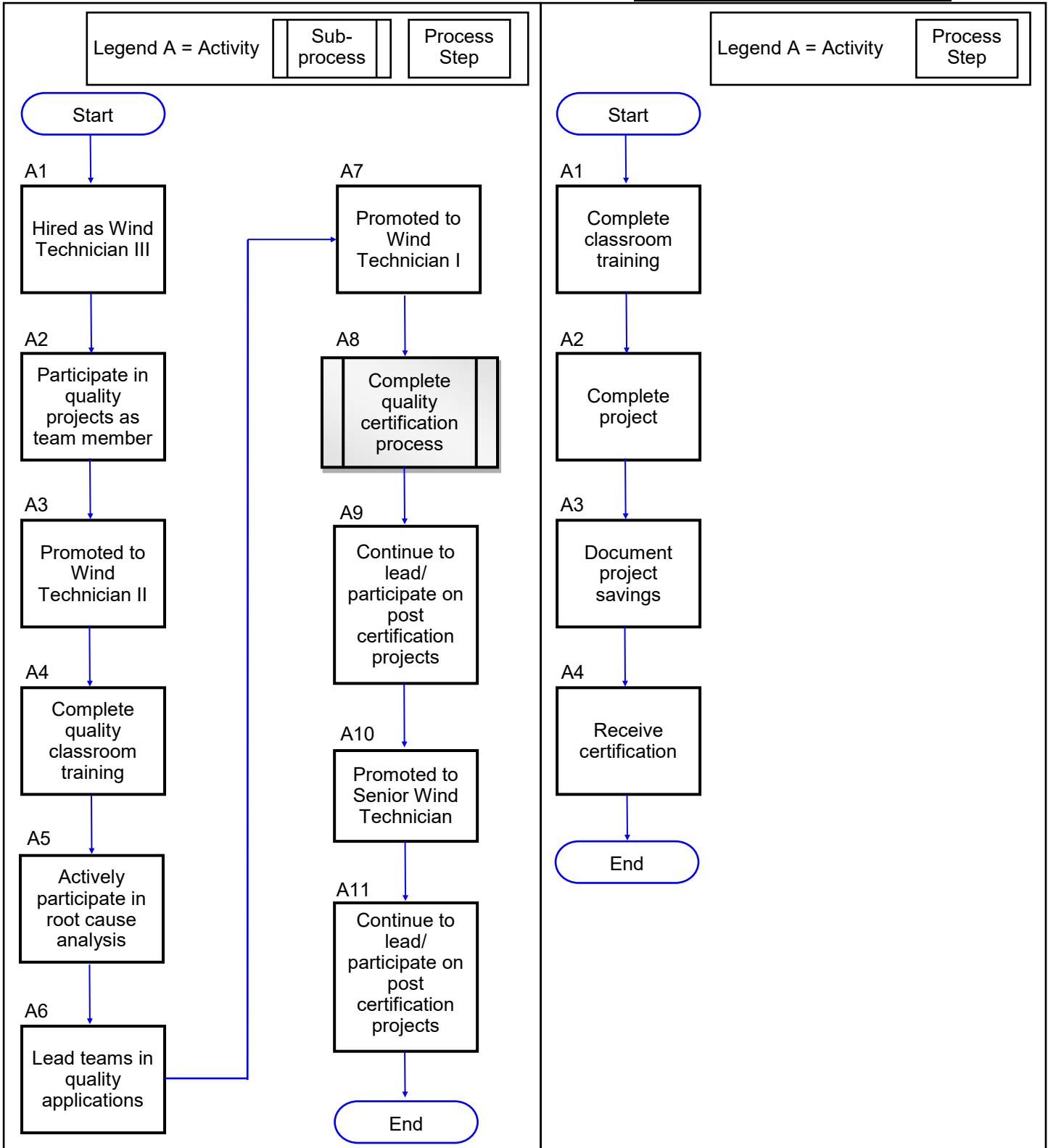

6.4. Lean Workshops and Frequent Kaizen Events

The company will provide opportunities for technicians to provide feedback on lean workshops and schedule Kaizen events. These types of activities are scheduled based upon the needs and priorities of the organization.



A technician would not be expected to lead the event; however, they must be part of a team for the duration, which lasts three to five days, in order to provide their field experience and technical knowledge of the problem. The event normally requires process mapping. The technician works with the team to identify areas of the process in which there is opportunity for improvement. The technician would help to identify value add, business value add, and non-value add activities. A technician may even be called in for a short duration in order to provide feedback on the activities of the team or to offer their knowledge for the problem at hand. An example would be to help identify which types of waste exist in the process, including transportation, inventory, motion, talent, waiting, over-production, over-processing, or defects.

Participation in these events can present the technician with opportunities to work on an individual “Quality Improvement Story”. Data can be collected, after the process is mapped and indicators are identified, for measuring the process health. Any gaps in performance would be good candidates for potential “Quality Improvement Story” projects.



Countermeasure identification and implementation in lean workshops and Kaizen events are based upon team consensus and management discretion utilizing the data driven problem-solving methodology.

7. Practical Examples

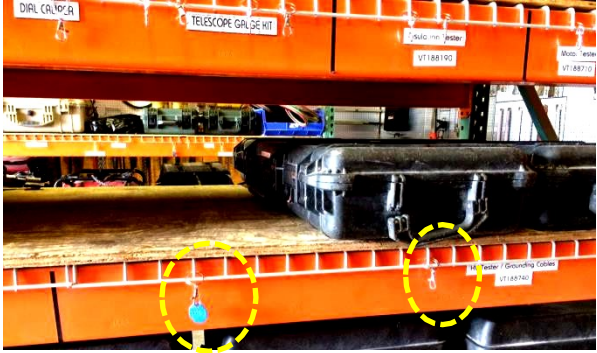
7.1. Warehouse Management





| | |
|---|--|
|  |  |
| <p>Shadowing tools allows for quick visual inventory</p>  | <p>Initials are stamped into a set of chits, for individual and daily use, to rapidly locate a tool if needed. Management chits leverage a distinctive color for calibrations or repair situations</p>  |

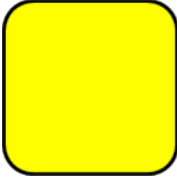
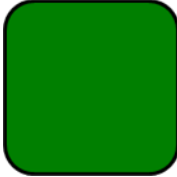

Example 1: Tool Shadowing and Chit System

| | |
|---|---|
|  |  <p>A custom system was built that reduces the weight and space of tanks up tower, while decreasing the time deliver nitrogen.</p> <p>This system came from a collaborative, multilevel improvement effort including technicians, site mangers, and operations support team members</p> |
|---|---|

Example 2: Custom Tool Kits and Custom Nitrogen Pump System

7.1. Warehouse Management
(continued)

| | | | | |
|---|---|--|---|---|
|  |  |  |  |  |
| Traffic Lanes | Safety Needs | Work Area | Restricted Access | Clear per Code |
| Designated egress ways for foot travel | Clearance for eye wash, first aid, and spec packs | General label for work areas and tool storage | Examples include: forklift, defective parts, oil storage | Clearance for electrical panels and fire extinguishers |

Example 3: Visual Controls and Floor Tape

7.1. Warehouse Management (continued)

|  | <p>Front end user experience allows employees to drag their name “in” and “out” while visitors can create profiles.</p> | | | | | | | | | | | | | | | | | | | | | | | | | | | | | | | | | | | | | | | | | | | | | | | | | | | | | | | | | | | | | | | | | | | | | | | | | | | | | | | | | | | | | | | | | | | | | | | | | | | | | | | | | | | | | | | | | | | | | | | | | | | | | | |
|---|---|----------|----------|---------|----------|----------|------------|---------------|---------------|--|--|--|----------|-------|----------|-------|-------|-------------|--|--|--|----------|-------|----------|-------|----------|-------------|--|--|--|----------|-------|----------|-------|-------|-------------|--|--|--|----------|-------|----------|-------|-------|-------------|--|--|--|----------|-------|----------|-------|-------|-------------|--|--|--|----------|-------|----------|-------|-------|-------------|--|--|--|----------|-------|----------|-------|-------|-------------|--|--|--|----------|-------|----------|-------|-------|--------|--|--|--|----------|-------|----------|-------|-------|--------|--|--|--|----------|-------|----------|-------|-------|--------|--|--|--|----------|-------|----------|-------|-------|--------|--|--|--|----------|-------|----------|-------|-------|--------|--|--|--|----------|-------|----------|-------|-------|--------|--|
|  <table border="1"> <thead> <tr> <th>Full Name</th> <th>Company</th> <th>Visitime</th> <th>Date In</th> <th>Time In</th> <th>Date Out</th> <th>Time Out</th> <th>Total Time</th> <th>Location Name</th> </tr> </thead> <tbody> <tr><td></td><td></td><td></td><td>23/01/17</td><td>14:54</td><td>23/01/17</td><td>14:55</td><td>00:00</td><td>Head Office</td></tr> <tr><td></td><td></td><td></td><td>22/01/17</td><td>00:03</td><td>23/01/17</td><td>14:52</td><td>38:49:00</td><td>Head Office</td></tr> <tr><td></td><td></td><td></td><td>22/01/17</td><td>00:02</td><td>22/01/17</td><td>00:02</td><td>00:00</td><td>Head Office</td></tr> <tr><td></td><td></td><td></td><td>21/01/17</td><td>23:58</td><td>21/01/17</td><td>23:59</td><td>00:01</td><td>Head Office</td></tr> <tr><td></td><td></td><td></td><td>21/01/17</td><td>23:56</td><td>22/01/17</td><td>00:15</td><td>00:18</td><td>Head Office</td></tr> <tr><td></td><td></td><td></td><td>21/01/17</td><td>23:54</td><td>22/01/17</td><td>00:15</td><td>00:20</td><td>Head Office</td></tr> <tr><td></td><td></td><td></td><td>21/01/17</td><td>23:50</td><td>21/01/17</td><td>23:59</td><td>00:09</td><td>Head Office</td></tr> <tr><td></td><td></td><td></td><td>21/01/17</td><td>23:48</td><td>22/01/17</td><td>00:15</td><td>00:26</td><td>Site 2</td></tr> <tr><td></td><td></td><td></td><td>21/01/17</td><td>23:24</td><td>21/01/17</td><td>23:25</td><td>00:01</td><td>Site 3</td></tr> <tr><td></td><td></td><td></td><td>21/01/17</td><td>23:22</td><td>21/01/17</td><td>23:25</td><td>00:03</td><td>Site 4</td></tr> <tr><td></td><td></td><td></td><td>21/01/17</td><td>23:21</td><td>21/01/17</td><td>23:21</td><td>00:00</td><td>Site 5</td></tr> <tr><td></td><td></td><td></td><td>21/01/17</td><td>23:20</td><td>21/01/17</td><td>23:21</td><td>00:00</td><td>Site 6</td></tr> <tr><td></td><td></td><td></td><td>21/01/17</td><td>23:16</td><td>21/01/17</td><td>23:20</td><td>00:03</td><td>Site 7</td></tr> </tbody> </table> | Full Name | Company | Visitime | Date In | Time In | Date Out | Time Out | Total Time | Location Name | | | | 23/01/17 | 14:54 | 23/01/17 | 14:55 | 00:00 | Head Office | | | | 22/01/17 | 00:03 | 23/01/17 | 14:52 | 38:49:00 | Head Office | | | | 22/01/17 | 00:02 | 22/01/17 | 00:02 | 00:00 | Head Office | | | | 21/01/17 | 23:58 | 21/01/17 | 23:59 | 00:01 | Head Office | | | | 21/01/17 | 23:56 | 22/01/17 | 00:15 | 00:18 | Head Office | | | | 21/01/17 | 23:54 | 22/01/17 | 00:15 | 00:20 | Head Office | | | | 21/01/17 | 23:50 | 21/01/17 | 23:59 | 00:09 | Head Office | | | | 21/01/17 | 23:48 | 22/01/17 | 00:15 | 00:26 | Site 2 | | | | 21/01/17 | 23:24 | 21/01/17 | 23:25 | 00:01 | Site 3 | | | | 21/01/17 | 23:22 | 21/01/17 | 23:25 | 00:03 | Site 4 | | | | 21/01/17 | 23:21 | 21/01/17 | 23:21 | 00:00 | Site 5 | | | | 21/01/17 | 23:20 | 21/01/17 | 23:21 | 00:00 | Site 6 | | | | 21/01/17 | 23:16 | 21/01/17 | 23:20 | 00:03 | Site 7 | <p>Back end system data provides a simple export of attendance records eliminating the need for duplicate entry, mistake prone paper time cards.</p> |
| Full Name | Company | Visitime | Date In | Time In | Date Out | Time Out | Total Time | Location Name | | | | | | | | | | | | | | | | | | | | | | | | | | | | | | | | | | | | | | | | | | | | | | | | | | | | | | | | | | | | | | | | | | | | | | | | | | | | | | | | | | | | | | | | | | | | | | | | | | | | | | | | | | | | | | | | | | | | | | | |
| | | | 23/01/17 | 14:54 | 23/01/17 | 14:55 | 00:00 | Head Office | | | | | | | | | | | | | | | | | | | | | | | | | | | | | | | | | | | | | | | | | | | | | | | | | | | | | | | | | | | | | | | | | | | | | | | | | | | | | | | | | | | | | | | | | | | | | | | | | | | | | | | | | | | | | | | | | | | | | | | |
| | | | 22/01/17 | 00:03 | 23/01/17 | 14:52 | 38:49:00 | Head Office | | | | | | | | | | | | | | | | | | | | | | | | | | | | | | | | | | | | | | | | | | | | | | | | | | | | | | | | | | | | | | | | | | | | | | | | | | | | | | | | | | | | | | | | | | | | | | | | | | | | | | | | | | | | | | | | | | | | | | | |
| | | | 22/01/17 | 00:02 | 22/01/17 | 00:02 | 00:00 | Head Office | | | | | | | | | | | | | | | | | | | | | | | | | | | | | | | | | | | | | | | | | | | | | | | | | | | | | | | | | | | | | | | | | | | | | | | | | | | | | | | | | | | | | | | | | | | | | | | | | | | | | | | | | | | | | | | | | | | | | | | |
| | | | 21/01/17 | 23:58 | 21/01/17 | 23:59 | 00:01 | Head Office | | | | | | | | | | | | | | | | | | | | | | | | | | | | | | | | | | | | | | | | | | | | | | | | | | | | | | | | | | | | | | | | | | | | | | | | | | | | | | | | | | | | | | | | | | | | | | | | | | | | | | | | | | | | | | | | | | | | | | | |
| | | | 21/01/17 | 23:56 | 22/01/17 | 00:15 | 00:18 | Head Office | | | | | | | | | | | | | | | | | | | | | | | | | | | | | | | | | | | | | | | | | | | | | | | | | | | | | | | | | | | | | | | | | | | | | | | | | | | | | | | | | | | | | | | | | | | | | | | | | | | | | | | | | | | | | | | | | | | | | | | |
| | | | 21/01/17 | 23:54 | 22/01/17 | 00:15 | 00:20 | Head Office | | | | | | | | | | | | | | | | | | | | | | | | | | | | | | | | | | | | | | | | | | | | | | | | | | | | | | | | | | | | | | | | | | | | | | | | | | | | | | | | | | | | | | | | | | | | | | | | | | | | | | | | | | | | | | | | | | | | | | | |
| | | | 21/01/17 | 23:50 | 21/01/17 | 23:59 | 00:09 | Head Office | | | | | | | | | | | | | | | | | | | | | | | | | | | | | | | | | | | | | | | | | | | | | | | | | | | | | | | | | | | | | | | | | | | | | | | | | | | | | | | | | | | | | | | | | | | | | | | | | | | | | | | | | | | | | | | | | | | | | | | |
| | | | 21/01/17 | 23:48 | 22/01/17 | 00:15 | 00:26 | Site 2 | | | | | | | | | | | | | | | | | | | | | | | | | | | | | | | | | | | | | | | | | | | | | | | | | | | | | | | | | | | | | | | | | | | | | | | | | | | | | | | | | | | | | | | | | | | | | | | | | | | | | | | | | | | | | | | | | | | | | | | |
| | | | 21/01/17 | 23:24 | 21/01/17 | 23:25 | 00:01 | Site 3 | | | | | | | | | | | | | | | | | | | | | | | | | | | | | | | | | | | | | | | | | | | | | | | | | | | | | | | | | | | | | | | | | | | | | | | | | | | | | | | | | | | | | | | | | | | | | | | | | | | | | | | | | | | | | | | | | | | | | | | |
| | | | 21/01/17 | 23:22 | 21/01/17 | 23:25 | 00:03 | Site 4 | | | | | | | | | | | | | | | | | | | | | | | | | | | | | | | | | | | | | | | | | | | | | | | | | | | | | | | | | | | | | | | | | | | | | | | | | | | | | | | | | | | | | | | | | | | | | | | | | | | | | | | | | | | | | | | | | | | | | | | |
| | | | 21/01/17 | 23:21 | 21/01/17 | 23:21 | 00:00 | Site 5 | | | | | | | | | | | | | | | | | | | | | | | | | | | | | | | | | | | | | | | | | | | | | | | | | | | | | | | | | | | | | | | | | | | | | | | | | | | | | | | | | | | | | | | | | | | | | | | | | | | | | | | | | | | | | | | | | | | | | | | |
| | | | 21/01/17 | 23:20 | 21/01/17 | 23:21 | 00:00 | Site 6 | | | | | | | | | | | | | | | | | | | | | | | | | | | | | | | | | | | | | | | | | | | | | | | | | | | | | | | | | | | | | | | | | | | | | | | | | | | | | | | | | | | | | | | | | | | | | | | | | | | | | | | | | | | | | | | | | | | | | | | |
| | | | 21/01/17 | 23:16 | 21/01/17 | 23:20 | 00:03 | Site 7 | | | | | | | | | | | | | | | | | | | | | | | | | | | | | | | | | | | | | | | | | | | | | | | | | | | | | | | | | | | | | | | | | | | | | | | | | | | | | | | | | | | | | | | | | | | | | | | | | | | | | | | | | | | | | | | | | | | | | | | |

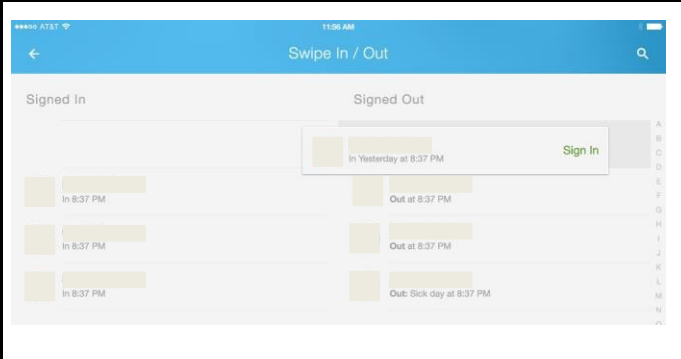
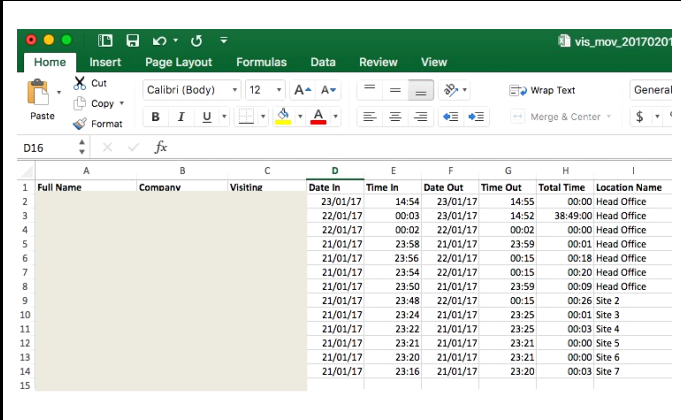
Example 4: Cloud Based Sign-in Board

References

- [1] balancedscorecard.org. Balance Scorecard Institute, “Balanced Scorecard Basics,” 2017. [Online]. Available: <https://www.balancedscorecard.org/BSC-Basics/About-the-Balanced-Scorecard>.

American Wind Energy Association
1501 M St. NW, Suite 900
Washington, DC 20005
www.awea.org